

Ericsson's IP-based BSS and radio network server

Niilo Musikka and Lennart Rinnbäck

The IP-based base station system (IP BSS) is designed to support both GSM BSS and TDMA-EDGE (EGPRS-136) radio access networks. It provides a future-proof path to the GSM EDGE radio access network (GERAN), since it has been optimized to handle a mix of data (GPRS and EDGE) and real-time services, such as voice traffic.

The authors describe the architecture of the IP BSS, the main functionality of the network elements, and the salient features of this new radio access solution.

System architecture

Ericsson's Internet protocol-based base station system (IP BSS) is built on a server-gateway architecture—that is, the network elements that handle payload are separate from the servers that control traffic. All switching is handled inside the IP network. The IP BSS consists of five main parts (Figure 1):

- the radio network server (RNS);
- the radio base station (RBS);
- the BSS gateway (GW);
- the real-time IP network; and
- the operation and maintenance (O&M) system, which includes subnetwork management.

The introduction of IP does not give rise to any perceived functional changes to voice and data services. The IP BSS supports standard GSM services and air interface protocols, and connects to the core network via standard ETSI and ANSI interfaces.

Functionality of the main parts

RNS

In the IP BSS, the radio network server handles all radio network logic and call control. By radio network logic, we mean the selection of cells for mobile stations (MS) that are in active mode, and air-interface channels. The radio network server is responsible for

- setting up and releasing connections between a mobile station and the mobile services switching center (MSC);
- coordinating the assignment of traffic channels; and
- controlling handover.

It also distributes paging to all cells that belong to a location area (LA) or a base station controller (BSC) area. No payload data is routed through the radio network server. The IP network handles all switching, or more correctly, routing. Other RNS functionality includes control of the gateway, optimization of performance data, and configuration of radio base stations.

For general packet radio service (GPRS), the radio network server allocates radio channel resources to be used by the radio base station. It is also responsible for the signaling entity to the serving GPRS support node (SGSN). The radio network server thus handles auto-configuration and negotiates user datagram protocol (UDP) and IP endpoints relative to the SGSN.

BOX A, ABBREVIATIONS

3GPP	Third-generation Partnership Project	FM	Fault management	OS	Operating system
ANSI	American National Standards Institute	GEM	Generic Ericsson magazine	PDH	Plesiochronous digital hierarchy
API	Application program interface	GERAN	GSM EDGE radio access network	PHB	Per-hop behavior
AU	Application unit	GO	Global object	PM	Performance management
BSC	Base station controller	GPRS	General packet radio service	PPP	Point-to-point protocol
BSS	Base station system	GSM	Global system for mobile communication	QoS	Quality of service
BSSAP	BSS application part	GW	Gateway	RBS	Radio base station
BTS	Base transceiver station	HDLC	High-level data link communication	RFC	Request for comments
CIC	Circuit identity code	IP	Internet protocol	RLC	Radio link control
CM	Configuration management	IRP	Integration reference point	RNS	Radio network server
CMH	Connectionless message handler	J2SE	Java 2 standard edition	SCB-RP	Support and connection boards with integrated regional processors
CORBA	Common object request broker architecture	JNDI	Java naming and directory interface	SCCP	Signaling connection control part
cPCI	Compact peripheral component interconnect	JVM	Java virtual machine	SGSN	Serving GPRS support node
CRM	Cell resource manager	LAN	Local area network	SNM	Subnetwork manager
DHCP	Dynamic host configuration protocol	MAC	Media access control	SS7	Signaling system no. 7
DiffServ	Differentiated services	MGW	Media gateway	STM	Synchronous transfer mode
DSCP	Differentiated services code point	MIB	Management information base	TCP	Transmission control protocol
DTX	Discontinuous transmission	MIM	Management information model	TDMA	Time-division multiple access
EDGE	Enhanced data services for global evolution	MO	Managed object	TRC	Transcoder controller
EEM	Embedded element manager	MPPP	Multilink PPP	TRX	Transceiver
EM	Element manager	MS	Mobile station	UDP	User datagram protocol
ETSI	European Telecommunications Standards Institute	MSC	Mobile services switching center	UMTS	Universal mobile telecommunications system
		NLS	Name lookup service	UTRAN	UMTS terrestrial radio access network
		NM	Network management system	WAN	Wide area network
		O&M	Operation and maintenance		

RBS

The radio base station, which includes radio transmission and reception functions for the air interface, is controlled by the RNS when voice calls are set up to mobile stations. The actual voice frames are sent directly to the transcoder in the gateway. Basic software and hardware parameters are set in the operation and maintenance system. Faults that occur on circuit boards and other explicit hardware are reported directly to this system. Apart from reports on lost capacity, no reports are made to the radio network server.

The radio network server orders the configuration of the physical resources that represent a cell. To handle the GPRS/EDGE packet service, the radio base station includes radio link control (RLC) and media access control (MAC), which manage packet data traffic to and from the SGSN and mobile stations. The radio base station also includes an embedded IP router which distributes packets internally and which can be used for connecting several radio base stations in a cascading configuration.

BSS gateway

The gateway is composed of a media gateway and a signaling system no. 7 (SS7) gateway. The media gateway

- is responsible for pools of transcoders that handle speech and circuit-switched data services;
- participates in handover; and
- connects transcoders to a particular circuit on the A-interface. On request by the radio network server, a resource manager in the media gateway allocates resources and sets up or switches connections.

The SS7 gateway handles SS7 signaling to the mobile services switching center and distributes BSS application part (BSSAP) messages to the correct entity (processor) in the radio network server. The transmission control protocol/Internet protocol (TCP/IP) is used for the signaling of BSSAP messages between the SS7 gateway and the radio network server. The O&M system is used for loading software into and configuring the gateway building blocks.

O&M system

The O&M functionality is built into dedicated subnetwork managers (SNM) and the network elements (Figure 2). Each network element thus includes its own element manager. TCP/IP is used for all management communication. Several means of commu-

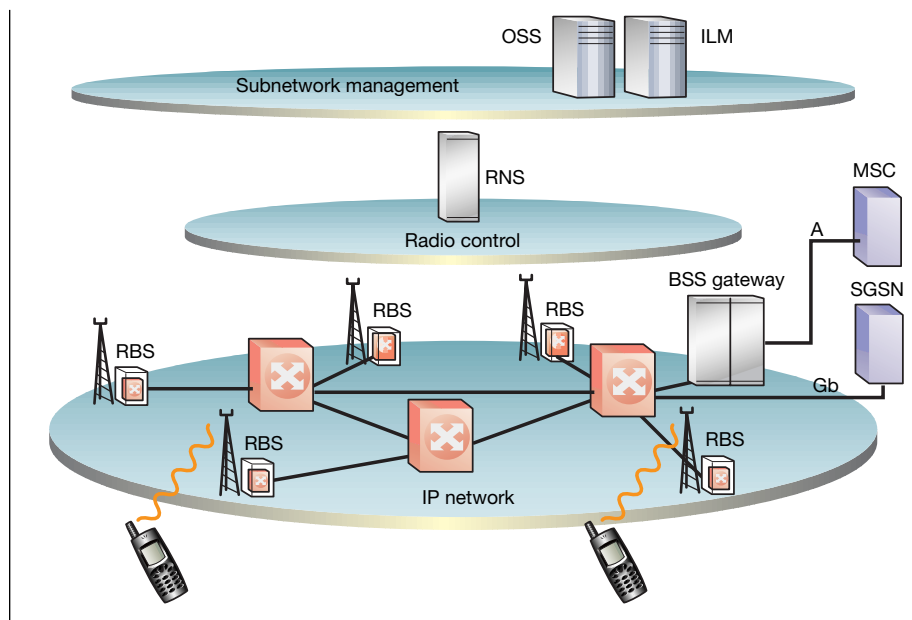
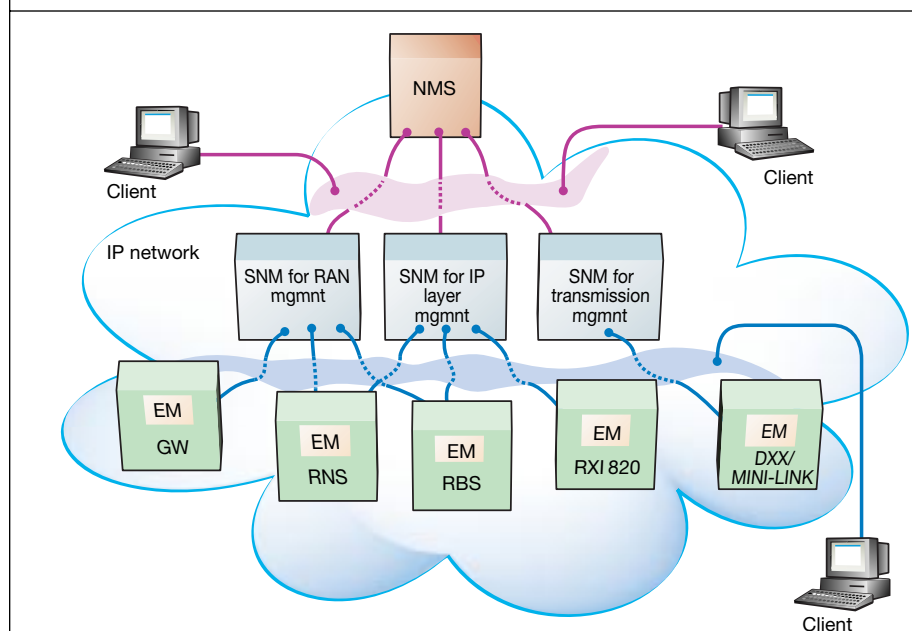

Figure 1
System architecture.

nication are provided for the communication between network elements and the O&M system—for example, the network elements contain Web pages that can be read by any browser with the appropriate access rights. A command line interface has also been provided.

Figure 2
Operation and maintenance system.



The element managers interwork with the subnetwork manager over an interface that has been based on the common object request broker architecture (CORBA). The subnetwork manager can integrate raw fragmented performance data into a single coherent picture for presentation to the operator.

Apart from the radio base stations, whose cell parameters are configured by the radio network server, all network elements are configured by the O&M system or by themselves. Subscriptions between a network element and the subnetwork manager can be set up to have the network element provide events that enable the keeping of real-time statistics. This capability can be used to obtain an overview of the number of calls per cell, or for local troubleshooting.

The IP BSS is simple to install and facilitates the deployment of numerous nodes.

- When the network element is connected to the transmission network it begins detecting transmission parameters. It then configures itself (layers 1 and 2) accordingly.
- An IP connection can then be established between the network element and the IP network. The network element communicates with IP network servers to obtain IP addresses and other data that enable it to communicate over the IP network.
- Finally, the network element is configured according to the specified radio network plan (that is, it downloads cell parameter settings, such as frequency and power levels).

The O&M system includes an IP layer management function that is used for managing the IP network. IP network implementations for wireless systems are composed of

numerous nodes, either stand-alone or embedded in radio base stations. To address the need for cost-effective, large-scale management, Ericsson has developed the IP layer manager¹, which includes support for the automatic configuration of large-scale IP-based mobile networks. It also includes a sophisticated means of managing IP network performance, in order to support end-to-end real-time sessions for delay-sensitive applications and signaling.

Real-time IP network

The IP network handles all routing in the system. Quality-of-service (QoS) properties (differentiated services, DiffServ) permit real-time traffic to be carried with minimum delay. If differentiated services cannot be provided, then bandwidth must be dimensioned to provide minimum delay for real-time traffic. The IP network uses real-time IP routers that have been optimized for the requirements of wireless data and voice traffic.¹ Ericsson's RXI 820 real-time router was designed specifically to meet the requirements in this part of the network.

Simple traffic case: call to a mobile station

A paging command arrives over the A-interface to the SS7 gateway. The complete SS7 stack is terminated in the gateway (the RNS does not need to include an SS7 stack) and the paging command is sent via TCP/IP to the radio network server, which distributes the paging command to the appropriate radio base stations (Figure 3).

A radio base station detects a channel request and signals the radio network server. The radio network server selects a dedicated radio channel and directs the mobile station to it. The radio network server also signals to the SS7 gateway, instructing it to set up a signaling connection control part (SCCP) connection to the mobile services switching center.

The mobile station then starts sending measurement reports over the dedicated channel. The radio base station forwards these measurement reports to the radio network server and sends its own measurements for further evaluation.

The mobile services switching center assigns a circuit identity code (CIC) on the A-interface and signals this to the radio network server (via the SS7 gateway), which instructs the media gateway to allocate a transcoder. The media gateway connects the transcoder to the CIC. The radio network

Figure 3
Traffic case: call to a mobile station.

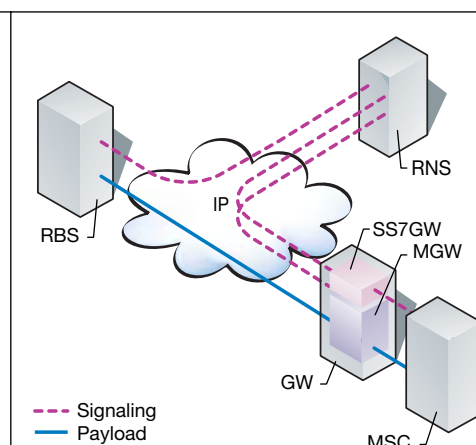

server also informs the radio base station and transcoder of their counterparts' IP addresses. The call can now be exchanged.

Operator benefits

System architecture

The IP BSS architecture has been designed to handle third-generation real-time multimedia services, GPRS and EDGE, and voice over IP. It can be connected to a second-generation core network via *A* and *Gb* interfaces, and to a third-generation core network via *Iu* (UTRAN) interfaces. The IP BSS thus constitutes a big step toward the wireless Internet and all-IP networks.

The server-based architecture separates control from payload, which means that each platform has been tailored to specific needs. The radio network server is a control node and the gateway handles payload.

The simplicity of traditional connectionless IP technology makes for efficient transport of packets, since no signaling is needed for setting up connections.

Transmission

Thanks to its layered structure, the IP paradigm offers a great degree of flexibility. Indeed, any physical and link layer technologies can be used. Therefore, new, optimized link layer technologies can be introduced without affecting the application software of the IP BSS.

By using IP, it is possible to dimension bandwidth according to actual traffic instead of by peak allocation. In terms of transmission, this yields significant savings, especially for bursty GPRS or EDGE traffic as well as for voice traffic that is transmitted by means of discontinuous transmission (DTX).

The embedded routers in the radio base station and stand-alone routers at hub sites can yield additional savings in transmission. A router can be used as an aggregation device by

- aggregating traffic from several transceivers in the embedded router in the radio base station; and
- aggregating traffic from several radio base stations in a hub site.

Depending on the extent of aggregation, the subsequent bandwidth requirement is less than the sum of the individual links from the radio base stations. Routers can be used instead of remote base station controllers. The scheduling of differentiated services (in the routers) differentiates traffic according

to priority, which further increases the use of the links.

The management of transmission in the radio access network can also be simplified: instead of managing individual plesiochronous digital hierarchy (PDH) timeslots, the bandwidth in the BSS network can be extended independently of transceivers (TRX). If a good performance-monitoring tool is used, new transceivers can be commissioned at radio base station sites without having to coordinate this action with extensions of the transmission network.

Other IP-based services can easily be connected to the same access network—for instance, to use spare capacity and reduce costs. However, care must be taken to guarantee the quality of service of the radio access network.

O&M

The distributed Web-based operation and maintenance architecture ensures accessibility and user-friendliness with fewer inter-node dependencies. The operator can access any radio base station, radio network server, or gateway from any terminal. Since each radio base station has its own IP address, it is possible to connect to it directly, to determine the cause of a problem.

A local area network (LAN) for operation and maintenance has been introduced at the radio base station site. The LAN is an Ethernet connection from the embedded router in the RBS for connecting other site equipment that implements its own IP-based O&M. To minimize the cost of installation and operation, all IP BSS products support a high level of plug-and-play functionality.

During low traffic hours, greater bandwidth is available for operation and maintenance. Indeed, the entire bandwidth can be used for O&M signaling when traffic is low. At night, for example, excess capacity can be used for downloading software to radio base stations.

For fault and performance management, the operator can define filters and subscription functions to specify the kind of data each network element is to send to the subnetwork manager. This is particularly useful for monitoring certain network elements.

Integration reference points (3GPP or Ericsson-specific) are used for communication from the subnetwork manager to the network management system. All configuration data is stored in the network elements, thereby ensuring that the data is always up-to-date and consistent. Copies of

the data are not kept at other parts of the O&M system. If required, however—for improved performance, or for some other reason—data can be cached in the subnetwork manager.

IP transport

The challenge

The characteristics of the radio access network for GSM base station systems and TDMA-EDGE are as follows:

- A large amount of traffic is delay-sensitive, real-time voice traffic. This traffic is transferred in small packets of approximately 35 octets, where each packet includes one speech frame. Packets that contain best-effort data are normally much larger (greater than 500 octets).
- The bandwidths available on links in the radio access network—especially in the last few kilometers to radio base stations—are very low (less than 1.5 to 2 Mbit/s). In many markets, these links are also expensive to lease.
- A typical radio access network consists of several hundred radio base stations, each of which must have a stable network synchronization clock in order to fulfill the stringent requirements for generating radio frequencies.

The solution

- Ericsson's solution for the IP BSS features
- quality-of-service differentiation by delay

and drop priorities (differentiated services architecture);

- low delay, thanks to the use of homogeneous packet sizes (long packets are broken down into smaller fragments by means of the multilink point-to-point protocol, MPPP);
- bandwidth efficiency using TCP/UDP header compression;
- policing—overflow traffic is discarded; and
- IP layer management with a high degree of automation for configuration management and performance monitoring.¹

Quality-of-service differentiation

The IP BSS network handles several flows of traffic streams (compressed speech, GPRS, traffic signaling, and network signaling). Because the nature of each traffic stream is unique, each stream must be forwarded independently in the network nodes. Accordingly, the IP BSS network uses differentiated services, as defined in RFC 2475. In a DiffServ network, the routers forward the packets of different traffic streams according to the per-hop behavior (PHB) assigned to the packets. A differentiated services code point (DSCP) in the IP header of each packet (Figure 4) indicates the per-hop behavior.

The applications that generate IP packets mark them with a DSCP according to the level of service that the application requires. The metering, dropping and scheduling are optimized in the routers to give good voice service and to maximize the use of available bandwidth resources. For instance, a large part of the bandwidth can be allocated to operation and maintenance when no higher-priority end-user services are in progress.

Operators can configure the mapping of end-user service classes into queues. However, the service classes for internal IP BSS functions cannot be configured.

Low delay using homogenous packet sizes

On narrowband links, long packets must be broken into smaller fragments, in order to keep speech packets from being delayed. The packets are broken into fragments at the link layer, using the multilink PPP (Figure 5).

If more than one DiffServ class must be fragmented, the multilink PPP can be complemented by the MPPP multiclass extension, to give optimal separation between fragmented quality-of-service classes.

Figure 4
IP header.

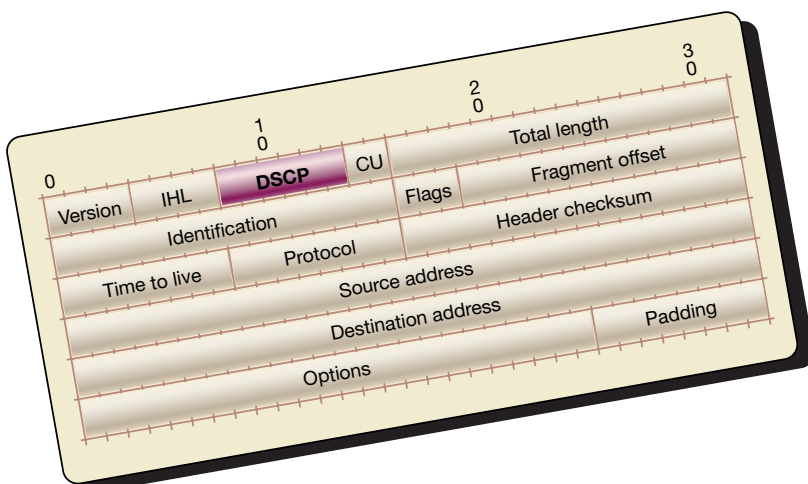

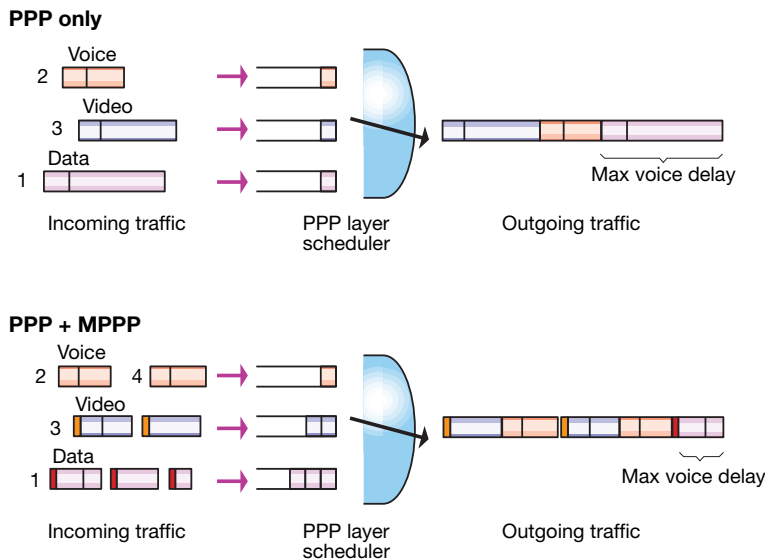

Figure 5
Fragmentation.

Bandwidth efficiency using TCP/UDP header compression

The UDP/IP header (28 octets) must be compressed to obtain efficient transmission. UDP/IP header compression reduces the header to just 5 to 10 octets, including PPP and high-level data-link communication (HDLC) overhead. The header compression technique is described in RFC 2507.

Policing—discarding overflow traffic

At the edge of the DiffServ IP network, traffic is grouped into quality-of-service classes. The traffic is also compared to defined traffic contracts, to determine if it is to be admitted into the network. However, as relates to the base station system, all applications that send traffic into the network from base stations or gateways are trusted. The role of traffic contract mechanisms can thus be reduced to that of handling error cases. Each defined traffic-generating unit (such as a radio base station) is allocated a maximum bandwidth that it may never exceed.

Homogenous implementation of real-time routers in the IP network

Ericsson is implementing the same real-time router technology throughout the IP network to guarantee that delay-sensitive services are handled in an optimized fashion. Besides the stand-alone RXI 820, Ericsson's real-time router is embedded in

the base station. In subsequent releases, it will also be embedded in gateways. This homogenous implementation of real-time routers in the IP network guarantees optimized end-to-end real-time performance. Similarly, it allows for

- a homogenized O&M solution for all IP components; and
- rapid deployment of new functionality—by means of simultaneous network-wide software upgrades—without affecting interoperability.

Where interworking relates to other manufacturers' routers, a distinction must be made between interoperability and real-time performance: interoperability is a standards issue, whereas real-time performance is dependent on the implementation. Ericsson's solution, which is fully based on open industry standards, guarantees end-to-end real-time performance without introducing weak links into the router chain.

Migration

Ericsson's current base station system can be upgraded to become an IP BSS. The upgrade consists of

- introducing the radio network server;
- introducing a new interface board for IP into the RBS 2000; and
- upgrading the base station controller and transcoder controller (BSC/TRC) to work

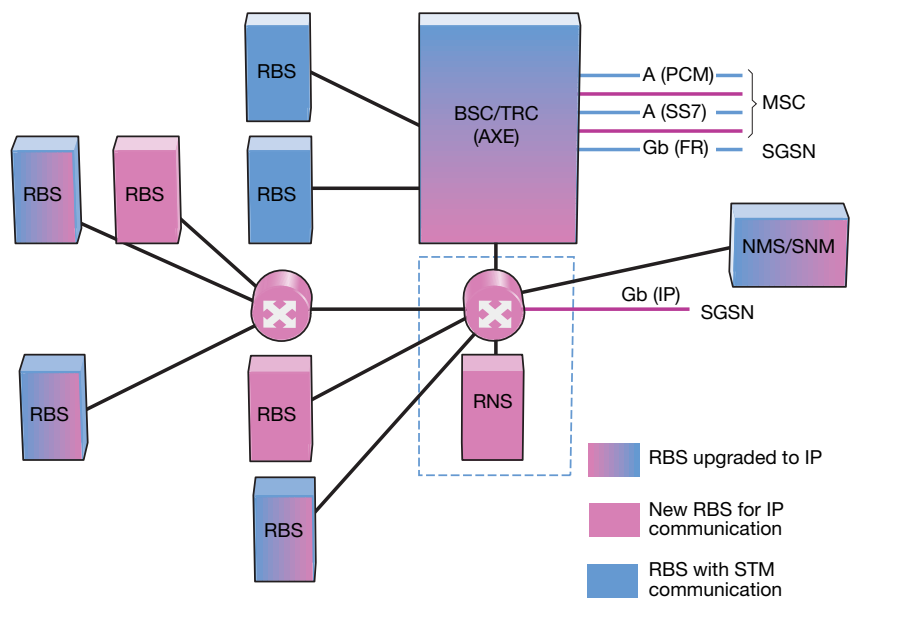

Figure 6
Evolution of the base station subsystem.

as a gateway and to enable it to connect to the IP network.

The combined BSC/TRC (Figure 6) functions as a gateway to IP-enabled radio base stations and radio network servers, and as an ordinary BSC/TRC for radio base stations that use synchronous transfer mode (STM). In a subsequent release, the gateway functionality will be implemented on the Cello packet platform used in Ericsson's third-generation mobile networks.² Operators of an Ericsson base station system can thus reuse a large part of their installed equipment when they upgrade to the IP BSS. The O&M system is the same for both the IP BSS and current base station systems.

The radio network server

The structure of the radio network server is divided into three main layers with subordinate layers:

- application software;
- system software; and
- hardware platform.

In general, a higher layer is solely dependent on the services provided by the layer imme-

diately below it. The RNS applications are dependent on the services provided by the application program interface of the system software platform. The number and type of processors and the means of inter-processor communication are hidden from the applications.

Benefits

The radio network server is based on Ericsson's TSP server platform. Thanks to industry-standard operating systems, processor boards, and components, this platform can quickly be adapted to new technologies. The use of common APIs and industry-standard development languages ensure openness, portability, and the ability to incorporate sourced components. The system software and Solaris operating system constitute the execution environment. The system software hides the underlying processing architecture from applications. The software can be upgraded during operation.

The hardware platform consists of a cluster of high-performance processors. The physical infrastructure of subracks equipped with processor boards and duplicated Ethernet switches provides scalability and high availability. All boards can be swapped (hot swapping) while the system is in operation. The radio network server is a robust and fault-tolerant system that has been designed especially for telecom applications. The application is divided into small software units that are distributed over the processing platform. This modular approach gives operators flexibility in configuring for different network scenarios. The dynamic distribution of load makes for efficient use of processing resources. If one processor fails, the affected application units are restarted quickly on other processors, which effectively means non-stop operation.

Hardware platform

The hardware platform is based on the generic Ericsson magazine (subrack) with two support and connection boards with integrated regional processors (SCB-RP). The boards are equipped with Ethernet switches. Via the backplane, processors are connected to the Ethernet switches for duplicated 100 Mbit/s inter-processor communication (Figure 7). The switching hierarchy has two levels. The SCB-RP boards with level-1 switches are placed at each end of a subrack. The level-2 Ethernet switches in-

terconnect the subracks by means of 1000Base-T links in a star configuration.

Besides the switches, each subrack contains interface boards for external communication and various processor boards. The smallest configuration is composed of a single subrack—this configuration can be expanded to encompass several subracks. The interface boards have 100Base-Tx links to the external router (RXI 820), which has wide area network (WAN) interfaces for connecting to other IP BSS nodes. The number of interface boards is dependent on the bandwidth needed for external signaling.

The processor boards are composed of UltraSPARC cPCI boards attached to adapter boards that provide electrical and mechanical conversion to the GEM backplane. Two processors serve as node control boards (one active and one in standby mode). Likewise, one processor per subrack serves as the boot server. Apart from these, all other processors are diskless.

The dual -48V DC power feed is distributed via the SCB-RP boards to the backplane. The voltage is converted on each board according to its specific level and power requirements. All boards support hot-swapping capabilities. The GEM subracks are stacked in a standard Ericsson BYB 501 cabinet.³

System software

The structure of the software platform has been divided into multiple layers (Figure 8). The bottom layer consists of the Solaris operating system.

The radio network server, which has mainly been developed in Java, exploits the versatility of the Java 2 standard-edition (J2SE) platform—that is, it includes support for concurrency, distribution, memory management, code loading, and IP communication.

On top of the Java 2 platform, various software platform services have been partitioned into an execution control layer, an interaction layer, and a system services layer.

The coordination layer manages threads, queues jobs, detects deadlocks, and protects against overload.

Execution control layer

The execution control layer, which uses some of the services provided by the Ronja/DPE middleware⁴, gives the application layer functions for high availability, in a way that minimizes impact on the appli-

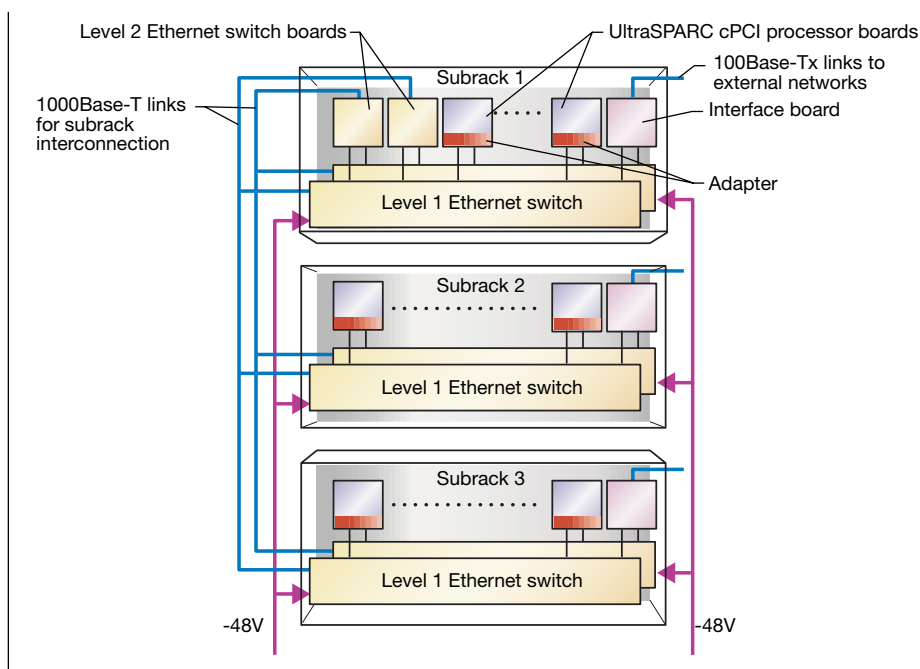

Figure 7
Hardware platform structure of the radio network server.

cation. The applications execute on a virtual machine and are unaware of the underlying processing architecture. The execution control layer provides the following services:

- applications can be divided into smaller application units (AU), which can easily be deployed in various combinations on multiple processors;
- takeover—to achieve a dynamic distribution of load between processors, the application units can be moved from one processor to another during operation without disturbing traffic;
- upgrades—the application units can be upgraded during operation and without disturbing traffic; and
- failover—failed units are restarted with minimal disturbance to traffic. If a processor fails, all affected application units are restarted on other processors.

Interaction layer

The interaction layer provides the application layer with a high-level communication interface that makes the application independent of the communication mechanism in use.

Figure 8
Layers of the software platform.

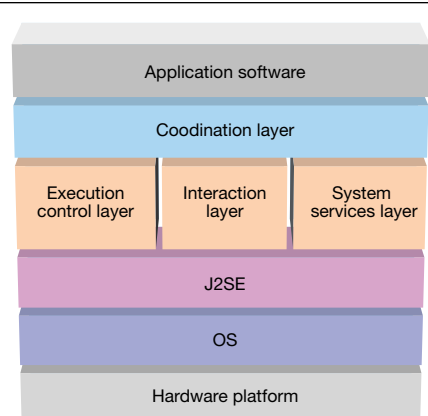

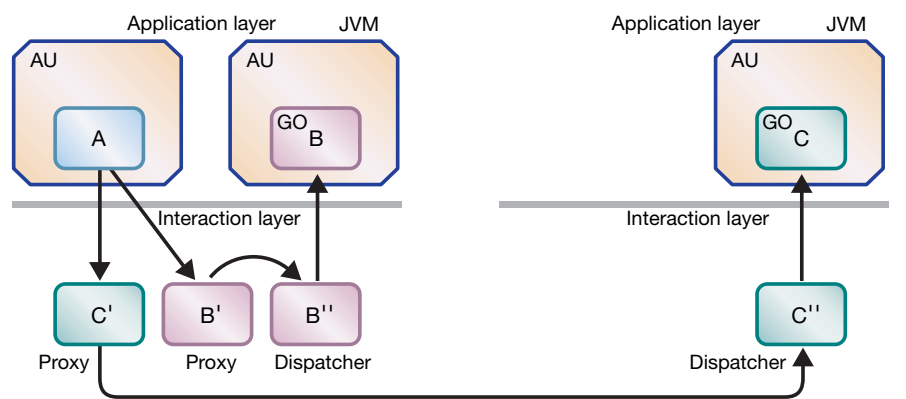

Figure 9
Internal communication of the radio network server via the interaction layer.

The interaction layer handles sockets and threads, and contains functions for encoding and decoding messages.

For internal RNS communication, the interaction is proxy-based (Figure 9). Different application units interact by means of global interfaces implemented by global objects (GO). The interaction layer provides the mechanisms that an application unit needs to invoke methods on a global object in another application unit, regardless of whether or not the application units are located on the same processor (JVM). The global object is found by means of a name lookup service (NLS).

Depending on the interface, several different protocols are used for external communication. The interaction layer establishes a logical connection between an RNS processor and an external node for exchanging asynchronous messages. The physical connection is hidden from the application.

System services layer

The system services layer consists of a naming service, logging service, timer service, and persistence service. The persistence service ensures that the configuration and traffic data persist and survive failures. The application unit actively saves its state to the system services layer, which replicates the state onto another processor. During failover a new application unit is created on the standby processor and its state is restored from the system services layer.

The naming service, which is based on the standard Java-naming-and-directory-

interface (JNDI) API, uses Jini lookup in the name lookup service (NLS). The name lookup service enables application units to establish contact with one another regardless of their locations.

Thanks to the NLS, the physical locations of different resources remain hidden from the application layer. Instead, logical names are used. These names do not change when the application units are moved to new locations.

RNS application architecture

The structure of the application software is divided into two main layers (Figure 10):

- the GSM application contains different kinds of application unit; and
- the operation-and-maintenance application contains an embedded element manager (EEM).

Additional applications can be located on the same layer as the GSM application. Different application configurations can be used.

GSM application

The GSM application controls circuit-switched connections in IP BSS networks. It also handles common signaling (such as paging) to a mobile services switching center or SGSN.

The cell resource manager (CRM) application unit serves every function that is related to a single cell—there are as many application units as there are cells served by the radio network server. The connectionless message handler (CMH) handles functions that are common to several cells. For example, the radio network server can serve one or more logical base station controllers—one CMH per BSC—which implies that a high-capacity radio network server can interwork with several MSCs or SGSNs.

The division of the GSM application into cell resource managers is the basis for distributing load dynamically (takeover). A cell application unit can be upgraded or restarted independently of other cell application units. The division of the GSM application into small autonomous cell application units is a foundation for very high availability. Most messages are routed directly between a cell application unit (cell resource manager) and the interaction layer without passing a central point, which further improves robustness. The GSM root (Figure 10) contains functions for creating or restarting application units, and controls

TRADEMARKS

All SPARC trademarks are used under license and are trademarks or registered trademarks of SPARC International, Inc. in the United States and other countries. Products bearing SPARC trademarks are based upon an architecture developed by Sun Microsystems, Inc.

Solaris™, Java™ and Jini™ are trademarks or registered trademarks owned by Sun Microsystems Inc. in the United States and other countries.

takeovers and upgrades. The cell resource manager is responsible for

- setting up and releasing connections between mobile stations and the mobile services switching center;
- assigning traffic channels; and
- media gateway interworking.

Each cell contains a pool of radio resources and an algorithm that allocates logical channels. Measurements from serving and neighboring cells are received by the locating algorithm, which determines handover. The source and target CRM application units interwork for handovers between cells.

Element management

The embedded element manager, which is responsible for the operation and maintenance of the RNS node (network element), serves the subnetwork manager client via an interface that is based on CORBA. It can also serve a thin client through a Web interface. The embedded element manager is an application unit that interworks with other application units in the GSM application.

The embedded element manager contains applications for configuration management (CM), fault management (FM), performance management (PM) and self-management. The configuration management part handles the configuration of radio network parameters. It is based on a management information model (MIM) that describes

- classes with attributes; and
- relationships between classes.

The configuration management part also contains a management information base (MIB) with managed objects (MO) that are instances of classes defined by the management information model.

The performance management part monitors, records, and supervises performance according to notifications received from the application units. The performance-monitoring function handles statistics gathered from counters and gauges; the performance-recording function handles events; and the performance-supervision function defines thresholds for a gauge—when the threshold is exceeded, it generates an alarm.

The fault-management part handles alarms, keeping a list and log of alarms.

The self-management part contains

- a hardware inventory—which includes the status of the RNS hardware; and
- a software inventory—which is used for managing software.

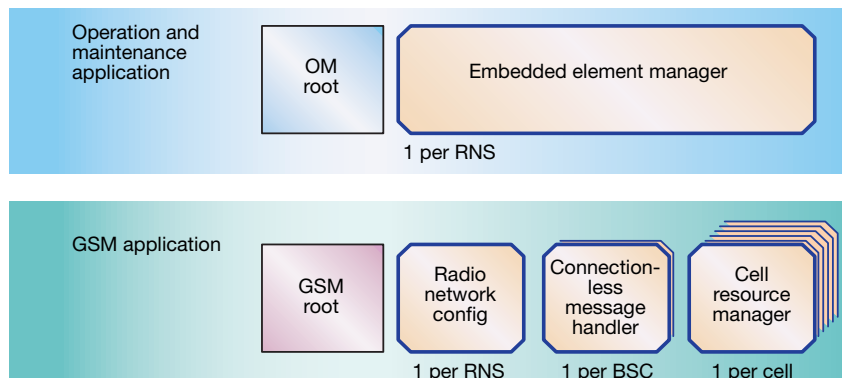

Figure 10
Layered application architecture.

Conclusion

The IP-based base station system (IP BSS), which is built on a server-gateway architecture, is designed to support both GSM BSS and TDMA-EDGE (EGPRS-136) radio access networks. The solution features quality-of-service differentiation, low delay, bandwidth efficiency (using TCP/UDP header compression), policing, and IP layer management with a high degree of automation for configuration management and performance monitoring. The IP BSS consists of

- an RNS, which handles all radio network logic and call control;
- an RBS, which includes radio transmission and reception functions for the air interface. The RBS is controlled by the RNS when voice calls are set up to mobile stations. The actual voice frames are sent directly to the transcoder in the gateway;
- a BSS gateway, which is composed of a media gateway and a signaling system no. 7 (SS7) gateway—the media gateway is responsible for pools of transcoders that handle speech and circuit-switched data services. It participates in handover, and connects transcoders to a particular circuit on the A-interface.
- a real-time IP network—all switching is handled inside the IP network; and
- an O&M system—the O&M functionality is built into dedicated subnetwork managers and network elements. Each network element includes its own element manager.

Ericsson's current base station system can be upgraded to become an IP BSS.

REFERENCES

- 1 Börje, J., Lund, H-Å. and Wirkestrand, A.: Real-time routers for wireless networks. Ericsson Review Vol. 76 (1999):4, pp. 190-197.
- 2 Reinius, J.: Cello—An ATM transport and control platform. Ericsson Review Vol. 76(1999):2, pp. 48-55.
- 3 Stockman, B. and Wallers, A.: The BYB 501 metric equipment practice. Ericsson Review Vol. 74(1997): 2, pp. 62-67
- 4 Karlson, M.: Ronja—A Java application platform. Ericsson Review Vol.77(2000):4, pp. 244-247.