

RNC3810—Ericsson's first WCDMA radio network controller

Bengt Gestner and Bengt Persson

While the role of a WCDMA radio network controller (RNC) is similar to that of a GSM base station controller (BSC), the differences between the two are big enough to justify a new RNC design, even among vendors who have the best BSC technology available.

The authors describe the RNC3810, its hardware and software architecture, and explain how it differs from a BSC.

The role of the RNC

As the cellular industry has evolved from first-generation to third-generation cellular systems, system architects have refined the role of nodes in the network. In hindsight, one can say that the architects of first-generation cellular systems, such as AMPS and NMT, had quite modest expectations regarding the scope of future traffic volumes. Accordingly, a simple architecture could meet these modest needs: all control resided within a single node—the mobile switching center (MSC)—which managed the call, the subscriber, mobility, and the base transceiver station (BTS).

When the system architects defined the architecture for GSM, they drew on experiences of first-generation networks, revising expectations for growth, improving multi-vendor capabilities, operations, and so on. New demands pointed to the need to sepa-

rate subscriber aspects from radio aspects. As a consequence, the MSC, BSC and BTS were designed as separate nodes. This architecture has served the industry well and allowed GSM networks to grow far beyond early expectations. As the name implies, the base station controller (BSC) is responsible for controlling base stations (BTS), including most handover tasks. All subscriber-related and most call-related tasks have been retained in the MSC.

Later, when work was begun on the architecture for third-generation systems (WCDMA), significant experience had been gained from second-generation systems. Numerous services that had not even been envisioned at the inception had been introduced successfully. However, the radio technology had shown itself to be more noticeable to the core network nodes than was desirable. Given the multitude of services envisioned in the Mobile Internet, the architects understood that they would need to better isolate the radio resources from the core network. They selected GSM as the base for the new architecture, but saw the shift in generations as a window of opportunity for making certain desirable adjustments (Figure 2). In the third-generation specification, the successor to the BSC has a modified role and a new name: radio network controller (RNC). The key external interfaces of the radio network are

- the air interface to the terminal or handset, designated *Uu*; and
- the interface to the core network, designated *Iu*. The *Iu* interface corresponds to the *A* and *Gb* interfaces in GSM and GPRS.

The internal interfaces of the radio access network are as follows:

- *Iub*—which corresponds to the *Abis* interface in GSM; and
- *Iur*—this is a new interface. It is required for performance in CDMA networks and to make mobility transparent to the core network.

RNC and BSC

At first glance the architecture of the GSM radio access network appears to be quite similar to that of the WCDMA radio access network. Therefore, one might assume that the BSC and RNC have more or less the same role or function. However, closer examination reveals a number of differences, most of which relate to the WCDMA radio access network and its architecture.

BOX A, TERMS AND ABBREVIATIONS

AAL2	ATM adaptation layer 2	NMT	Nordic mobile telephone
AMPS	Advanced mobile phone system	O&M	Operation and maintenance
ATM	Asynchronous transfer mode	OC	Optical carrier—SONET standard
BSC	Base station controller	OC-3	SONET transmission frame format for 155 Mbit/s
BTS	Base transceiver station	PDH	Plesiochronous digital hierarchy
CORBA	Common object request broker architecture	RANOS	Radio access network operation system
CPP	Cello packet platform	RNC	Radio network controller
CPU	Central processing unit	SCB	Switch core board
E1/T1/J1	PDH transmission frame formats for 2 Mbit/s (E1) alt. 1.5 Mbit/s (T1/J1) transmission rates	SDH	Synchronous digital hierarchy
ET	Exchange terminal	SONET	Synchronous optical network
GPB	General-purpose processor board	SPB	Special-purpose processor board
GSM	Global system for mobile communication	STM	Synchronous transport module
HTML	Hypertext markup language	STM-1	SDH transmission frame format for 155 Mbit/s
IP	Internet protocol	SXB	Switch extension board
IT	Information technology	TCP	Transmission control protocol
MPC	Main processor cluster	TEMS	Test Mobile System (product name)
MSC	Mobile switching center	TUB	Timing unit board
MSP	Multiplex section protection (G.783)	WCDMA	Wideband code-division multiple access
NBAP	Node B application protocol		

Soft handover

For reasonable radio performance, WCDMA—a direct-sequence CDMA technology—requires soft handover between cells, base stations and RNCs. This results in radio functions in the RNC, and requires interfaces to the RNC user plane and signaling between RNC control planes. Consequently, for a given call, the RNC has two logically separate operating and serving roles. In its operating role, the RNC manages cells and base stations (Node B). In its serving role, the RNC manages radio connections. Ordinarily, both roles belong to the same RNC, but after handover the operating role may move to another physical RNC, controlling the base station used by the terminal.

Integrated service and future-proof interfaces

Some of the services that have been added to GSM have led to the creation of new interfaces, for example, for positioning services. These services have been integrated into third-generation systems and interfaces. The interfaces have been restructured to limit the risk of having future services affect them. As part of this clean-up, the responsibility for “mobility” in the RNC and the use of radio resources have been clarified, and differences in the interfaces to the

packet-switched and circuit-switched domains of the core network have been reduced.

Packet transport network

Many third-generation applications are expected to generate traffic as bursts of TCP/IP packets. To use transmission resources efficiently, packet transmission technology is needed. Initially, while preparing for other technologies (such as pure IP) the ATM/AAL2 transmission technology has been employed. The architecture solutions also enable the use of a dynamic switching infrastructure, which further reduces the cost of maintaining the network. The ongoing IT evolution also influences the architecture. Faster, smaller and cheaper semiconductors allow intelligence to be built into base stations, making them much more self-contained.

Implementation consequences

In terms of implementation, the most striking differences between an RNC and a BSC are as follows. The RNC

- uses packet-centric transmission (ATM);
- makes use of the *Iur* interface;
- consolidates the *Gb* and *A* interface in the *Iu* interface;



Figure 1
RNC3810, C-configuration.

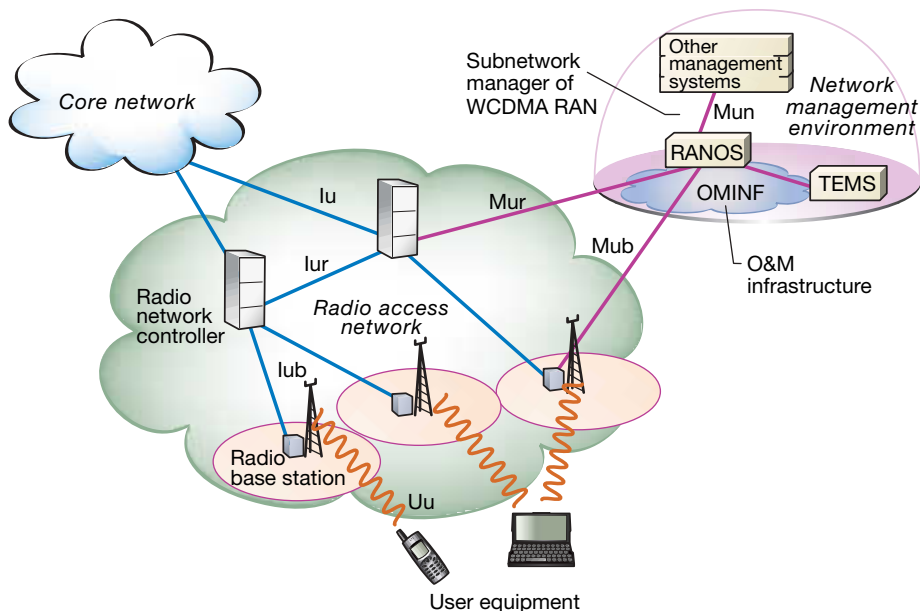

Figure 2
WCDMA radio access network.

BOX B, EXPERIENCES OF THE RNC IN THE EXPERIMENTAL WCDMA SYSTEM

Ericsson has used a step-by-step approach to developing WCDMA. The first step involved a technology demonstrator in the mid-1990s, followed by an experimental system in the late 1990s, and finally a pre-commercial system that was taken into operation in 2001.

The primary aim of the technology demonstrator was to support standardization and to gain expertise regarding the behavior of the air interface.

Likewise, the primary aim of the experimental system was continued support of standardization and to gain competence in system behavior. The experimental system was designed as a pre-commercial system that modeled a real network implementation. Therefore it could also be used to verify new product architectures, development principles and technologies.

Several of the technologies verified related to CPP. The experience gained from these activities was applied to the development of the commercial systems and platform.

- requires considerably more signaling per call; and
- has no transcoder, but instead uses the soft-handover splitting/combination to manipulate the user plane.

Most current BSC implementations are based on traditional telecommunications circuit switches for wire-line phone services. Major changes would be required to modify these to accommodate new third-generation requirements.

Packet-centric transmission can be used with second-generation BSCs provided an ATM interface is added and the switching matrix is greatly overdimensioned. As an alternative, the circuit switch can be replaced with an ATM switch. This is what Ericsson has been doing in its ENGINE solution.

The difference in switching versus CPU capacity is perhaps an even bigger challenge. The amount of signaling (and thereby required CPU power) per call varies at a ratio of 1:10:100 between wire-line switch, BSC and RNC applications. The main reasons for the variance between the BSC and the RNC are frequent soft handover events and adjustments of the radio channel (channel switching) in response to the packet nature of applications. In GSM there is approximately one handover per call, whereas in a loaded WCDMA network more than 10

handovers and other radio channel changes can be expected per call.

Although the total processing power required for the user plane in the RNC is greater than that of the BSC, nearly 80% of the hardware in the RNC3810 is employed for user-plane-related processing. Therefore, the difference in required processing power has little effect on the hardware architecture of the RNC. More significant is the difference in the nature of processing. In the BSC, transcoders with signal processors account for the majority of processing resources, whereas in the RNC the brunt of processing entails shuffling data using general-purpose processors. Another difference lies in the internal data paths. The BSC works with a strict multiplexing architecture, whereas the RNC requires full switching capabilities. Ericsson has thus developed a completely new node platform for the RNC based on the Cello packet platform (CPP). CPP is also used in other products, such as the RBS3000 and the media gateway.

RNC3810

The RNC3810, Ericsson's first RNC for WCDMA, has been optimized for scalability and easy upgrading—even during full-service operation. For example, a small configuration used during roll-out can easily be expanded to larger configurations having a throughput that surpasses that of many large BSCs.

The two central building blocks for the RNC3810 are the main subrack and the extension subrack. The smallest configuration contains only the main subrack. However, up to eight extension subracks can be added to provide capacity for serving some 375,000 subscribers on 500 base stations. The subracks are housed in one, two or three cabinets. The footprint of the largest configuration is less than 0.75 m² (Figure 3).

The logical and physical separation of transport and transmission interfaces from user plane processing makes it simple to connect the RNC to any core network and any access network configuration. The RNC can be equipped with transmission interfaces for ATM-, SDH- and PDH-switched networks on channelized as well as non-channelized STM-1/OC-3, E3/T3 and E1/T1/J1. Likewise, higher-order transmission and connectivity to IP networks can easily be introduced when the marketplace so requires.

Figure 3
RNC hardware expansion.

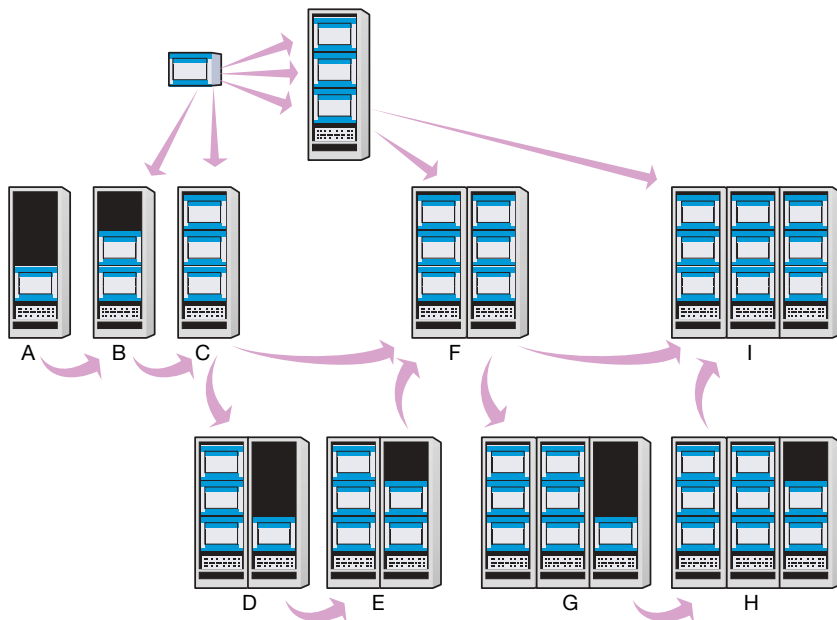

Cello packet platform

The RNC3810 is built almost entirely from products based on CPP—for example, for computing, transmission interfacing, and the ATM switching core.¹ CPP also provides a real-time operating system that features support for multiprocessing hierarchies and extensive solutions for redundancy handling. The following CPP hardware building blocks are used in the RNC:

- The switch core board (SCB) handles ATM switching. It is also the interface to four extension subracks using inter-subrack links (ISL).
- The switch extension board (SXB), which is an extension to the SCB, facilitates the connection of four more extension subracks.
- The general-purpose processor board (GPB) is the computing heart of the RNC (Figure 4). Several GPBs can form a main processor cluster (MPC).
- Special-purpose processor boards (SPB) are used for special, resource-intensive tasks, such as processing user-plane data.
- The timing unit board (TUB) provides the timing reference for the system.
- Exchange terminals—a family of transmission interface boards with standardized internal interfaces to the processing parts of the RNC (Table 1).

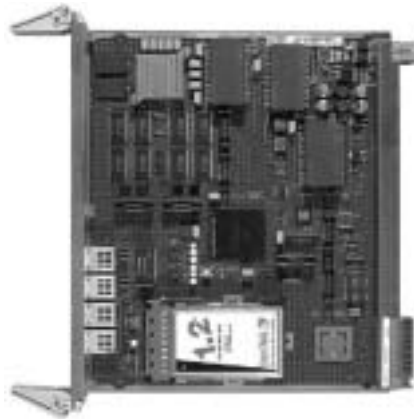

Figure 4
General-purpose processor board (GPB).

The board processor level (level three) can only be seen by the platform level in CPP. The WCDMA radio access network application solely uses levels one, two and four.

RNC module

The RNC module, which provides another way of looking at the RNC architecture, is a processor cluster made up of level-two and level-four processors by a logical definition in software. For instance, one level-two GPB and five level-four SPBs can be grouped into

TABLE 1, EXAMPLES OF EXCHANGE TERMINALS.

ET-M1	E1/T1/J1 for PDH networks
ET-M3	E3/T3 for PDH networks
ET-M4	STM-1/OC-3 for ATM-switched networks
ET-MC41	STM-1/OC-3 for SDH/SONET-structured E1/T1/J1

RNC3810 hardware architecture

RNC3810 has a four-tier processor hierarchy (Figure 5):

- At level one (hub level) three GPBs form the hub MPC. This configuration is duplicated in hot standby set-ups (6 GPBs). The processing tasks—O&M handling (*Mu* interface), signaling (*Iu* and *Iur*), and node control—are allocated to the processors in the multiprocessor cluster by configuration at software build.
- Level two (device level) is an RBS MPC that is physically implemented as a pool of GPBs whose main task is to provide the *Iub* interface.
- Level three (board processor level) constitutes a standardized internal computing interface. Each board contains a board processor regardless of the application. This level is not visible to the end-user of the RNC.
- Level four (user-plane level) consists of a pool of SPBs for intensive user-plane data processing for the dedicated channel, broadcast channel, and packet handling.

Figure 5
Processor hierarchy.

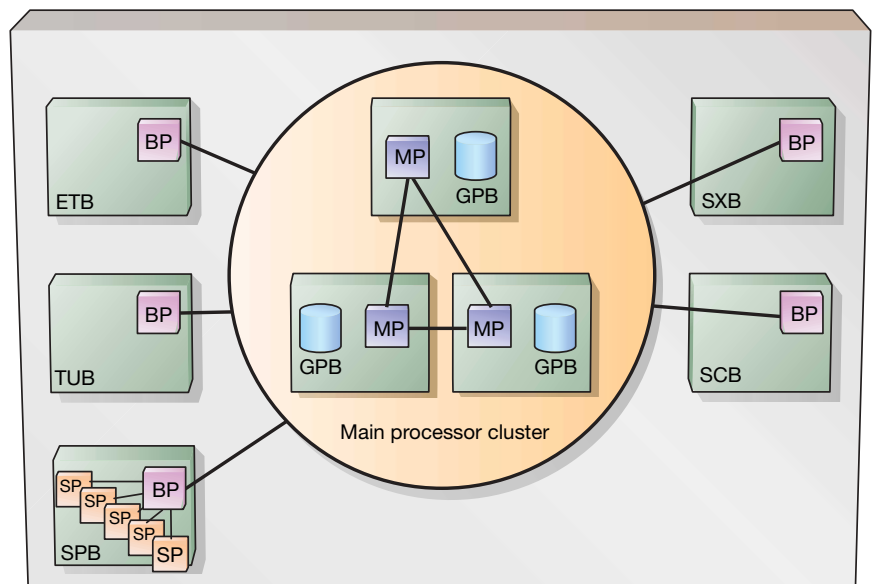

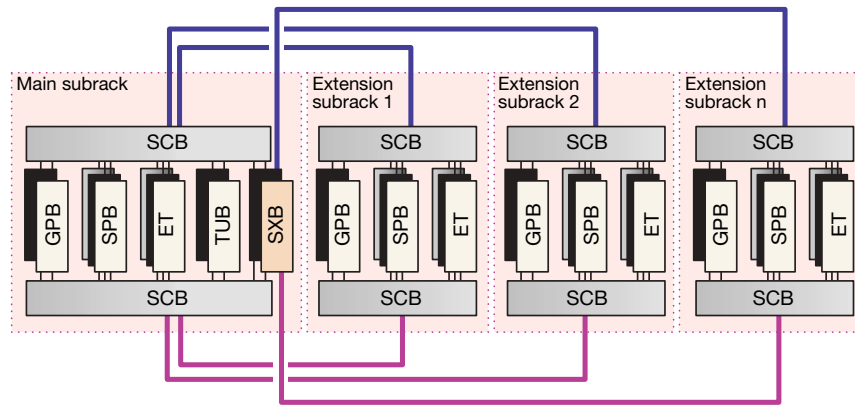
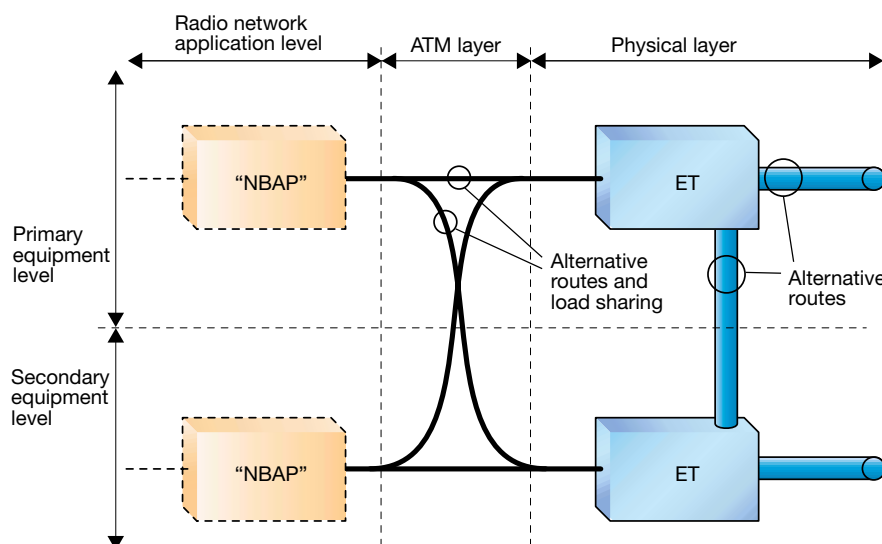

Figure 6
Duplicated interconnections.

a processor cluster—the RNC module. This is actually a small RNC that handles all system interfaces (*lu*, *lur* and *lub*) using hub-level computing resources and the standardized internal transmission interface for external access. More RNC modules means more capacity (near-linear relation). Although the RNC is a logical entity it can be physically mapped to the circuit boards of the extension subrack. This means that the addition of extension subracks also gives a linear growth in capacity.

Figure 7
Transmission redundancy.



In-service performance

Due to the large service capabilities required of the RNC, designers have gone to great lengths to ensure that it can operate continuously. One way of obtaining high availability in fault situations is to implement a high degree of redundancy (Figure 6). Therefore, the RNC3810 has no singular units. Besides redundantly configured processors, the RNC3810 has duplicated internal connections, fan units, and power feeding and distribution.

Redundancy is also used for updating hardware. Duplicate units can be forced into standby state, replaced, and then taken back into operation while the executive unit guarantees full operation. Both processors can be updated by toggling the state of an executive unit to standby and the standby unit to executive.

Transmission redundancy

The information transported on STM-1 links corresponds to large service areas. Therefore, continuous connectivity must be ensured. Two concepts guarantee high transmission availability to equipment and transmission links (Figure 7):

- alternative processing; and
- physical link protection.

Alternative processing is set up as duplicated instances of processing parts on the radio network application level. Each part, executing on separate processors, is connected to separate transmission branches using ATM switching functionality. The ATM switching functionality is also used for load sharing by dividing one flow of information onto two physical transmission lines. Physical link protection is implemented as MSP1+1 protection, which is to say that a fatal failure on one transmission link results

in automatic switchover to an alternative transmission line. MSP1+1 is also used to protect equipment on channelized STM-1 interfaces.

Restart mechanism

When recovering from a fault or from a hardware upgrade, the RNC is restarted using a “staircase” with three steps of escalation (Figure 8).

Step 1, or *program restart*, is the first system action taken to recover from a fatal state in a software application. This restart, which has little or no impact on the total service of the RNC node, is also the basic mechanism for upgrading specific parts of the software system. The upgrade is always made on a standby processor.

Step 2, or *processor restart*, is a hardware-oriented restart of the entire software application on a specific processor. This action is initiated when program restart is insufficient to recover from a fault situation or when major changes have been made in the application during system upgrade. This is also the regular way of taking a replaced hardware unit into operation.

Step 3, or *node restart*, which is an emergency alternative, is solely used in extraordinary fault situations. The entire node is reset and is thus not accessible for service during the initial phases of the restart. This step might also be used during extensive system upgrades to shorten the total time of upgrade but at the expense of service availability.

Software architecture

When developing the experimental WCDMA system, software architects used a high-level, object-oriented design and programming approach to evaluate time to

market, quality, and ease of adaptation to future requirements. Because this approach proved to be highly successful it has also been applied to the development of the RNC. To keep complexity and lead times at bay, standard middleware packages have been included to support relational real-time databases, IP, HTML, CORBA, SS7 signaling, and so on.

Great strides have been made to ensure that the structure would be scalable. When defining the programming model, objects that frequently interact have been kept in the same processor. Furthermore, functions that cannot be managed by a single processor in a very large node have been designed to work in a distributed fashion, thereby allowing load to be spread over several processors.

Evolution

Thanks to a modular hardware and software architecture, the product characteristics of CPP and the RNC3810 can easily be modified by changing the proportion of installed boards or board placement. Likewise, the internal building blocks or components can evolve independently of one another.

Conclusion

The RNC3810 represents a milestone in the evolution of cellular switching nodes. The first member of a family of products built on a new architecture and technology platform, it now stands at the commencement of a long and successful evolution.

The RNC 3800 family of products has been designed to meet every possible customer need in terms of size, scalability, in-service performance, functionality and transmission environment.

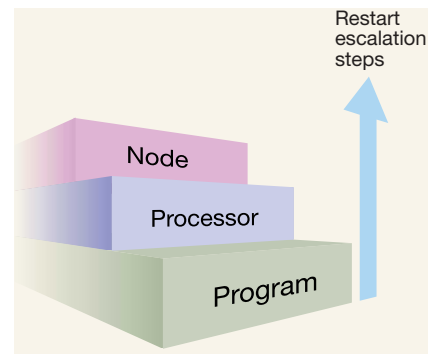

Figure 8
RNC restart escalation staircase.

REFERENCES

- 1 Reinius, J.: Cello—An ATM transport and control platform. Ericsson Review Vol. 76(1999):2, pp.48-55.