

Microwave capacity evolution

Microwave is a cost-efficient technology for flexible and rapid backhaul deployment to almost any location. It is the dominant backhaul media for mobile networks in the world today, and is expected to maintain this position during the evolution of mobile broadband.

» JONAS HANSRYD AND JONAS EDSTAM

New RAN architectures such as HSPA-evolved, LTE and heterogeneous networks have led to an ever increasing demand for backhaul capacity. In this article, key emerging gigabit per second (Gbps) microwave technologies that help address this issue are explored.

Background

Point-to-point microwave links are deployed using FDD with paired channels, and typically hop-by-hop licensing. Frequency bands are governed by channel plan recommendations from international organizations such as CEPT/ECC and ITU-R, and span a wide range of frequencies from 6GHz to 86GHz – as shown in **Figure 1**. Today, the majority of point-to-point links are installed in the lower (blue) bands, whereas the higher (red) frequency bands offer wider bandwidths but are more vulnerable to precipitation. As such, the higher bands are more suitable for short hops up to a few kilometers in range.

National spectrum regulators control

the availability of frequency and channel bandwidth; it is their responsibility to prioritize spectrum use among military, medical, space, automotive and fixed-service applications. Originally, the recommended channel bandwidths for point-to-point links were tailored for PDH/SDH transport networks based on a generic pattern of 3.5 or 2.5MHz channel spacing. The most common channels in Europe, for example, are 3.5, 7, 14 and 28MHz, with 56MHz channels available in some cases. Over the past few years, the rollout of mobile broadband has fueled the trend toward using wider channels to enable greater capacity in the microwave link. In Europe, 112MHz channels have been introduced and use of the 3.5MHz channels is declining.

It is estimated that mobile-broadband traffic will increase more than ten-fold during the next five years². Many operators consider microwave to be a potential capacity bottleneck for future mobile backhaul due to its relatively narrow frequency channel and lack of spectrum in hotspot sites needed

in densely populated areas. A typical mobile-backhaul network has thousands of hops, and operators must be able to increase microwave capacity without having to change frequency planning and replace equipment across their entire network.

This article reviews current and future microwave solutions with the potential for Gbps backhaul capacity levels, for rural and urban areas. The solutions presented make best possible use of the advantages of microwave technology, including fast deployment, flexibility and low total cost. The possibilities created by 112MHz channels in the 42GHz band and by wider channel bandwidths in the 70/80GHz bands are explored. Finally, test-bed results are presented with record-breaking 1024QAM modulation, 5Gbps single-carrier radios, the world's first line-of-sight (LoS) MIMO microwave demonstration and ultra-high spectral efficiencies offering Gbps transport capacity on a single 28MHz channel.

Breaking through the capacity barrier

This article defines capacity of a microwave link in two ways:

- ❖ gross bit rate through the air; and
- ❖ line rate (the actual capacity available to users for data transportation).

Line rate is equal to the gross bit rate minus overhead data such as forward error-correction coding and frame overhead. Using efficient coding, native TDM and Ethernet transport, overhead data typically occupies 5 to 10 percent of the gross bit rate.

A PDH microwave link in a 28MHz channel typically carries a line rate of 34Mbps. However, it is possible to reach Gbps bit rates through such a channel. Three methods can be used to increase the line rate:

- ❖ improve the gross bit rate;

BOX A Terms and abbreviations

3GPP	3rd Generation Partnership Project	Mbps	megabits per second
CEPT	European Conference of Postal and Telecommunications Administrations	MIMO	multiple-input, multiple-output
DWDM	dense wavelength division multiplexing	m-QAM	multi-level quadrature amplitude modulation
ECC	Electronic Communications Committee	PDH	Plesiochronous Digital Hierarchy
FDD	frequency-division duplexing	QAM	quadrature amplitude modulation
GbE	Gigabit Ethernet	RAN	radio-access network
Gbps	gigabits per second	SDH	synchronous digital hierarchy
HSPA	High-Speed Packet Access	SS-DP	spatially separated dual-polarized
ITU-R	International Telecommunication Union – Radio-communication	TDM	time division multiplexing
LoS	line-of-sight	WCDMA	Wideband Code Division Multiple Access
LTE	Long-Term Evolution	XPIC	cross-polarization interference cancellation

- ❖ apply traffic optimization techniques; and
- ❖ reduce the radio overhead.

The gross bit rate can be increased by widening the used bandwidth and by improving spectral efficiency through increasing the number of bits transmitted per frequency bandwidth.

Traffic-optimization techniques remove redundant content from data streams before transmission. In an Ethernet stream, traffic optimization could, for example, include removing interframe gaps or compression of the transported data. Data compression efficiency is highly dependent on the type of data transported. If data is randomly distributed, as is the case for compressed and encrypted data streams, compression gain is limited or non-existent. Mobile-broadband payload traffic is generally compressed, and encryption is the default choice for WCDMA traffic and recommended by 3GPP for LTE.

As radio overhead is considered to be low, and traffic optimization is generally applicable to any type of capacity-limited transport medium, this article focuses on methods for increasing the gross bit rate of a microwave link. Presented below are methods for:

- ❖ increasing operational bandwidth by using new frequency bands or multi-carrier channel aggregation; and
- ❖ improving spectral efficiency in a microwave link with emphasis on high-order modulation techniques and LoS MIMO.

The impact on reach and availability is discussed, as well as how adaptive modulation techniques can be used to extend the reach of high-capacity microwave links while guaranteeing a minimum bit rate with high availability.

Increasing the gross bit rate

Channel bandwidth limits the number of symbols per second that can be transmitted on a microwave carrier. Using advanced signal-processing techniques, the symbol rate may, in modern microwave systems, reach up to 0.9 times the channel bandwidth without violating spectrum masks. This implies that about 50Mbaud may be used for signaling in a 56MHz channel bandwidth. With m-QAM modulation, $\log_2(m)$ bits may be coded onto each symbol. Thus,

FIGURE 1 Microwave frequency bands recommended for fixed services by ITU-R and CEPT/ECC¹

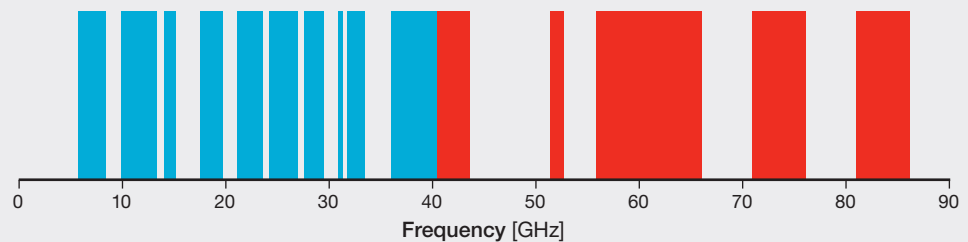

BOX B

In Figure 1, the blue bars indicate frequency bands used today, while red indicates frequency bands that are available, but currently not widely used for point-to-point microwave links.

using a 56MHz channel and 1024QAM modulation – 10 bits per symbol – a gross bit rate of 500Mbps may be transmitted on a single carrier.

Receiver sensitivity is reduced by about 3dB for every extra bit coded onto the signal. Consequently, an increase from 2 bits per symbol (4QAM) to 10 bits per symbol (1024QAM) results in a loss in total system gain of at least 24dB (see Equation 1). In practice, the reduction in system gain will be even greater because the increased order of modulation places more extensive requirements on the linearity of the radio, thus limiting the transmitter output power. Initial capacity gain is inexpensive; with an increase from 2QAM to 4QAM, the gross bit rate is doubled at the expense of 3dB loss in system margin. However, for higher-order modulation, capacity increase comes at a high cost for system gain. For example, an increase from 512QAM to 1024QAM results in a capacity increase of just 11 percent.

Adaptive modulation

Microwave links need to be designed with a sufficient fading margin to cater for signal deterioration caused by rain or multipath propagation, for example. In this way, high-priority traffic – such as voice – can be transmitted with maintained availability during periods of heavy rain. Because heavy rain conditions occur infrequently, the additional fading margin can be used to transport data by increasing the order of modulation. In the event of rain, path loss will increase and the link will switch to a lower-modulation format, saving system gain and preventing the link from being interrupted. This method

of adapting the modulation format is referred to as adaptive modulation.

When channel attenuation is high, traffic throughput for low-priority services can be reduced for short periods of time while maintaining normal availability for high-priority services. A link, originally designed for 4QAM, can in most cases support up to 1024QAM modulation 99 to 99.9 percent of the time, while maintaining telecomm-grade availability (99.999 percent) for high-priority services supported by the 4QAM modulation.

In practice, adaptive modulation is a prerequisite for highly available, high-order modulation point-to-point microwave links over long hop lengths – tens of kilometers. However, to reach Gbps transport rates on 56MHz channels and below, multi-carrier solutions are needed. With wider channels, such as 112MHz and above, single-carrier solutions with Gbps capacity are possible.

Radio-link bonding

The latest RAN technologies – HSPA-evolved and LTE – enable higher gross bit rates through carrier aggregation. Microwave links for trunk (long-haul) networks have used this capability for a long time, and today it is also available for microwave links in the access network. This method of transporting traffic evenly across two or more microwave carriers is referred to as radio-link bonding.

Radio-link bonding also supports an efficient link-protection scheme, where both links can be used for transport. If one of the links fails, the second radio will maintain support for high-priority services. This is known as ❖❖

FIGURE 2 Maximum hop length limited by path attenuation for 70mm/h rain versus system gain and carrier frequency

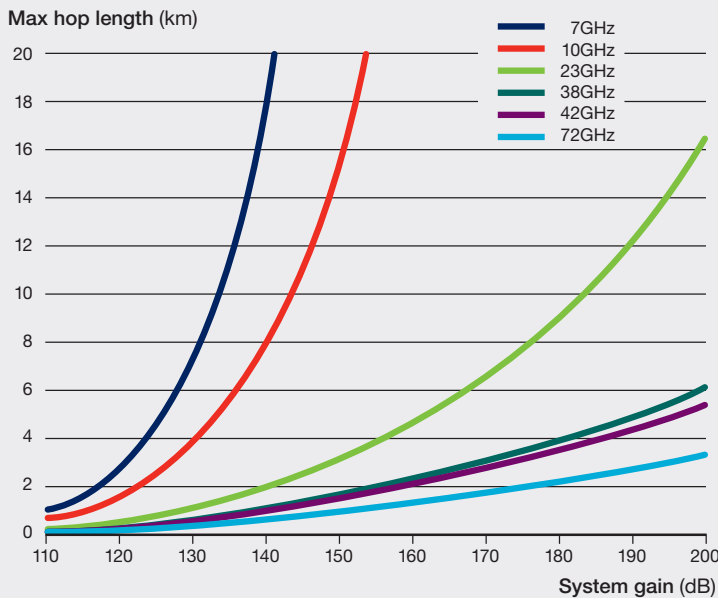

BOX C

New frequency bands channel bandwidths

CEPT/ECC recommendation (01)04-2010 divides the 42GHz band, allocated from 40.5GHz to 43.5GHz, into: 12 x 112MHz; 25 x 56MHz; 50 x 28MHz paired channels; and a number of 3.5MHz, 7MHz and 14MHz channels³.

The 70/80GHz band is allocated from: 71-76GHz and from 81-86GHz with a total of 20 paired 250MHz channels that can also be aggregated⁴.

❖ 2+0 protection, as opposed to 1+1 protection, where one link is used to transport and the other remains in standby mode for backup purposes. The same protection scheme could be applied to intense-rain regions that lack rain-tolerant channels. Capacity can be increased by combining a low-frequency rain-tolerant microwave link with a high-frequency link with reduced rain tolerance. The low-frequency link will guarantee high-priority services while the high-frequency link, with reduced availability, will support lower-priority services.

Equation 1

System gain = $P_{tx} - P_{R_{xth}} + G_{ant1} + G_{ant2}$
 where: P_{tx} is the transmitted output power; $P_{R_{xth}}$ is the receiver threshold; and G_{ant1} and G_{ant2} are the antenna gains of radios 1 and 2, respectively.

New frequency bands

The lack of spectra supporting wide-channel bandwidths has been identified as a potential bottleneck for microwave backhaul. Many national regulators have recently adopted channel plans that allow for bandwidths of up

to 112MHz in bands below 40GHz. These bands were originally made available at a time when there was limited need for wide bandwidths, and as a result, they are populated mostly with narrow channels. Since the rollout of mobile broadband, many of the narrowest channels have been abandoned because they are unsuitable for data traffic. This has given spectrum administrators the opportunity to re-farm these bands with wider channels. An additional possibility is to open new, previously unused frequency bands such as the 42GHz band.

Box C details the CEPT/ECC recommendation for how the 42GHz and 70/80GHz bands can deliver 112MHz and 250MHz channel bandwidths. Using a single 112MHz channel, at 42GHz, it is possible to reach a gross bit rate of 1Gbps using 1024QAM modulation. In the 70/80GHz band, it is possible to aggregate neighboring channels to create wider ones. The Ericsson PT 6010 70/80GHz radio uses four 250MHz channels (1GHz bandwidth), to support line rates of 1GbE.

At the Mobile World Congress (MWC) in Barcelona in February 2011, Ericsson demonstrated a full-duplex 5Gbps radio

using 2.5Gbaud and 4QAM modulation.

As mentioned, higher-frequency bands (30GHz and above) are more sensitive to rain attenuation⁵, which consequently limits the maximum hop length for these bands in comparison with lower ones. Typical hop lengths range from 2km to 4km in most climate zones for carrier frequencies between 30GHz and 42GHz with five-nines (99.999 percent) availability. To achieve the same availability, the hop length for a 70/80GHz radio is somewhere between 1km and 2km, with appropriate hardware. Figure 2 shows calculated path-attenuated maximum hop length versus carrier frequency and typical system gain at a rain rate of 70mm/h – representing a typical European climate zone.

Path attenuation in Figure 2 is calculated according to recommendation ITU-R P.530-13⁶. The rain-attenuated distance is greater for lower frequencies. Other effects, such as multi-path propagation and the curvature of the earth, may become limiting factors for hop lengths above 20km. With a typical system gain of 160-180dB, a realistic hop length with five-nines availability is 3km for a 42GHz link and 2km for a 70/80GHz link.

Example 1

A user has access to two separate single-polarized channels between two nodes:

- ❖ a 28MHz channel at 15GHz; and
- ❖ a 28MHz channel at 38GHz.

Each carrier is modulated with 1024QAM. Individually, each 28MHz carrier may transport a gross bit rate of 250Mbps. When aggregated, the two carriers can transport 500Mbps in a total bandwidth of 56MHz (28+28 MHz).

Spectrally efficient microwave links

A legacy microwave link on a 28MHz channel typically has a gross bit rate of 37Mbps, which corresponds to a spectral efficiency of 1.3bps/Hz. Although this may appear to be spectrally efficient, Figure 3 shows how spectral efficiency has increased by a factor of 30 in the past 10 years. In 2000, by spectrally shaping the signal at the transmitter, the symbol rate was increased from ~18.5Mbaud to ~25Mbaud on a

28MHz channel, corresponding to a spectral efficiency of 1.8bps/Hz. Since then, the order of modulation has been increased continuously, with 512QAM commercially available since mid-2010. In addition, a rate of 1024QAM using commercial radios has been demonstrated in labs.

Support for higher-order modulation is planned, but moving to higher-order modulation increases the requirements on the radio transmitter and receiver in terms of linearity and phase noise. Pre-distorting the signal at the transmitter using digital signal processing can compensate for non-linearity, and phase noise can be reduced through careful design of the radio and modem. Moving from 4QAM to 1024QAM corresponds to a fivefold increase in capacity, which in the above example would correspond to a gross bit rate of 250Mbps (8.9bps/Hz).

Increasing the gross bit rate to Gbps levels requires multiple carriers for 56MHz and narrower channels. The next section includes a discussion about two multi-carrier techniques – polarization multiplexing and spatial multiplexing – that enable multiple carriers to share the same channel, further increasing spectral efficiency.

Polarization multiplexing

Polarization multiplexing is a method for doubling spectral efficiency on a single channel. This method has been commercially available for point-to-point microwave links in the access network since mid-2000. It involves two single-carrier radios transmitting on the same frequency channel but with orthogonal polarizations (horizontal and vertical). Because the radios share the same carrier frequency, they can also share the same antenna.

Ideally, the two polarizations are completely isolated from each other. However, in practice, a small portion of the signal in one polarization will leak into the other. This can occur due to rotational misalignment between the antennas. In practice, it is difficult to achieve better isolation between the two polarizations than 25dB. Certain weather conditions, such as heavy rain, may further reduce the level of isolation that can reasonably be achieved. However, by sharing the received signal between the two modems, it is possible to cancel the interfering polarization using digital

signal processing. This technique is referred to as cross-polarization interference cancellation (XPIC).

Example 2

A user has access to a single 56MHz channel between two nodes. Using 1024QAM and 50Mbaud, a gross bit rate of 500Mbps can be transported per carrier – or a gross bit rate of 1Gbps using polarization multiplexing.

Line-of-sight MIMO

MIMO is a well-known technology for increasing spectral efficiency in WiFi and RANs. An $N \times N$ MIMO system comprises N transmitters and N receivers with the potential to simultaneously transmit N independent signals. For example, a 2×2 MIMO system contains two transmitters and two receivers, and can transport two independent

signals, thus doubling the link's capacity. The basic principle of MIMO is that a signal will use different paths between transmitters and receivers. In a 2×2 MIMO system, there are two possible paths between one transmitter and two receivers, as shown in Figure 4. The interfering signal can be cancelled if the difference in propagation between the two paths permits the two received signals to be orthogonal to each other at the receiver modems⁷⁻⁸. For a 2×2 system, this corresponds to a relative phase difference of 90 degrees. In conventional MIMO systems, the difference in path is achieved through reflexes in the environment. For microwave links, it is not possible to take advantage of objects in the environment because these links, by definition, are operated in LoS mode with highly directional antennas. In contrast, because the carrier

FIGURE 3 Evolution of spectral efficiency for microwave links

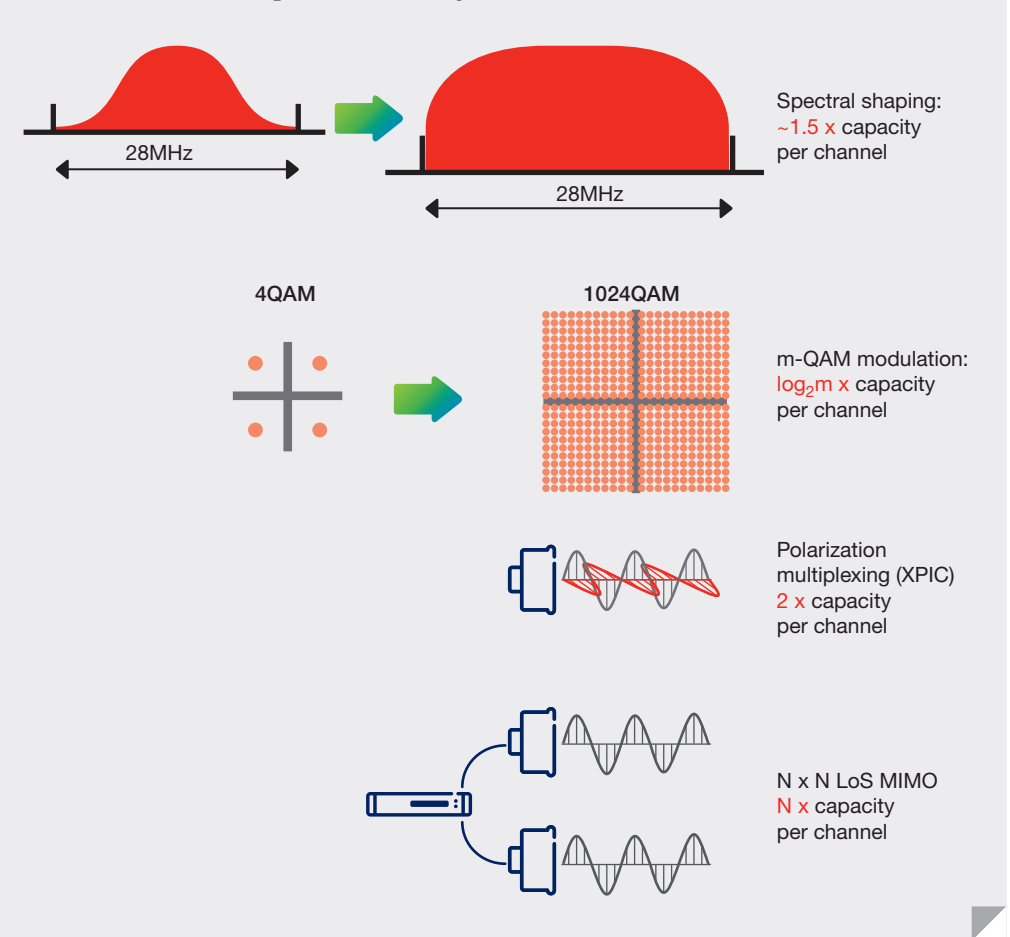
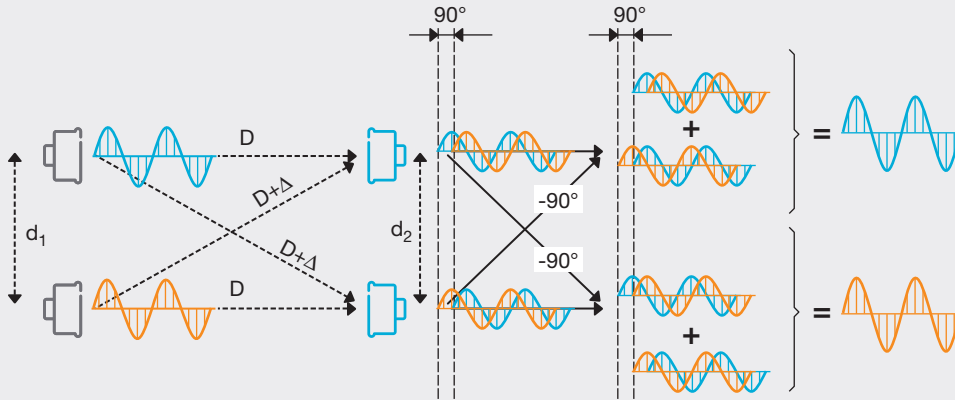

FIGURE 4 2x2 LoS MIMO basic principle



As frequencies for microwave links are high, it is possible to design a 2x2 MIMO channel with a phase difference of 90 degrees between short and long paths by spatially separating the radio antennas. This is commonly referred to as a LoS MIMO system. A geometric calculation indicates that the product of the two optimum antenna separation distances d_1 and d_2 should fulfill Equation 2.

Equation 2
 $d_1 d_2 = Dc/2f$

where: f is the carrier frequency; c is the speed of light in air; and D is the hop length.

Figure 5 shows theoretical gross bit rates for a single microwave channel using the methods described above. With single-carrier radios it is possible to reach 1Gbps gross bit rates for 112MHz channels. Using dual-carrier configurations (XPIC or LoS MIMO) it is possible to reach Gbps throughput on a 56MHz channel. Using quad-carrier configurations by combining XPIC and

FIGURE 5 Gross bit rates for a single-channel microwave link using different channel bandwidths, levels of modulation, and carrier multiplexing techniques

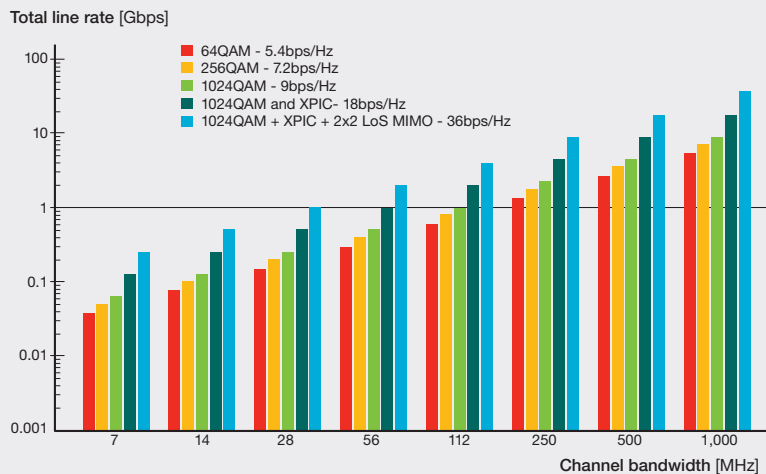

BOX D

Figure 6 shows an experimental outdoor LoS MIMO setup at Ericsson's test site in Mölndal, Sweden. Shown are four 32GHz radios mounted in a 4x4 SS-DP LoS MIMO configuration. The hop length is 1.3km and antenna separation distance is 2.5m.

LoS MIMO, it is possible to attain a Gbps gross bit rate on a single 28MHz channel. We refer to this configuration as 4x4 spatially separated dual-polarized (SS-DP) LoS MIMO.

As shown in Figure 5, extrapolating the spectral efficiency of 36bps/Hz to a 112MHz channel results in a gross bit rate of 3.6Gbps on a single channel. Taking it one step further and applying the same spectral efficiency to a 70/80GHz, 250MHz or 1,000MHz channel, we should be able to transport 8.1Gbps and 32Gbps respectively. These capacities are similar to transport levels on single channels in optical DWDM systems – indeed these transmission rates equal those achieved in current optical metro and core transport networks.

Demo at MWC 2011

Ericsson demonstrated 1Gbps throughput in a 28MHz channel for the first time at the Mobile World Congress in Barcelona in February 2011. By combining a 2x2 LoS MIMO system with polarization multiplexing, four commercial MINI-LINK radios at 10GHz were able to transmit four signals independently of each other. Using a single 28MHz channel and 512QAM modulation, a line rate corresponding to 1GbE was demonstrated with a spectral efficiency of 32.1bps/Hz. This is, to the best of our knowledge, the highest reported spectral efficiency achieved over a microwave link. Increasing the order of modulation to 1024QAM would result in a spectral efficiency of 36bps/Hz. A MINI-LINK system operating at a 28MHz channel bandwidth, 1024QAM modulation and 46dBi antenna gain would obtain a system gain of 160dB or higher for a carrier frequency below 40GHz. As shown in Figure 2, a 160dB system gain would – depending on the carrier frequency used – support hop lengths of tens of kilometers with Gbps capacity levels under 70mm/h rain conditions. This corresponds to five-nines availability in a European climate zone and shows that it is possible to support Gbps bit rates across hop lengths of the order of tens of kilometers in a 28MHz channel with telecom-grade availability.

Summary

This article provides an overview of

FIGURE 6 4x4 SS-DP LoS MIMO outdoor setup



microwave technologies that support the long-term capacity evolution of mobile broadband backhaul networks. Very high order modulation, adaptive modulation, radio-link bonding, polarization multiplexing and LoS MIMO are technologies that enable capacities in the order of several Gbps for microwave backhaul using commonly available frequency bands (6 to 40GHz). Applying these technologies to the wider channels of the newly available 42GHz and 70/80GHz frequency bands makes it possible to achieve backhaul capacities approaching 10Gbps and 40Gbps. Microwave is thus truly a fiber-through-the-air technology capable of supporting rapid mobile broadband deployment, and will remain an attractive and competitive choice for backhaul. ❖

Jonas Hansryd



❖ joined Ericsson Research in 2008 and is currently a senior researcher in broadband technologies. His focus is on high-capacity microwave links to meet the data-rate, latency and traffic-volume demands on mobile backhaul created by evolved HSPA and LTE. He has been involved in the development of high-capacity 70/80GHz microwave links, as well as LoS MIMO microwave communication systems. He holds a Ph.D. in electrical engineering from Chalmers University of Technology in Gothenburg, Sweden, and was a visiting researcher at Cornell University, Ithaca, US from 2003 to 2004.

Jonas Edstam



❖ joined Ericsson in 1995 and is currently responsible for technology strategies at Product Line Microwave & Mobile Backhaul, and is also an expert on microwave radio transmission networks. He has many years of experience in this area and has, in various roles, worked with a wide range of topics, from detailed microwave technology and system design to his current focus on the strategic evolution of packet-based mobile backhaul networks and RAN. He holds a Ph.D. in applied solid-state physics from Chalmers University of Technology in Gothenburg, Sweden.

Acknowledgements

Jens Albrektsson, Patrik Bohlin, Antonio Carugati, Mats Cedheim, Donato Centrone, Jingjing Chen, Tomas Danielson, Carmelo Decanis, Maria Edberg, Thomas Emanuelsson, Pasquale Esposito, Duccio Gerli, Kåre Gustafsson, Magnus Gustafsson, Ola Gustafsson, Björn Gäfvert, Andreas Hansen, Anders Henriksson, Dag Jungenfeldt, Johan Lassing, Filippo Leonini, Thomas Lewin, Yinggang Li, Per Ligander, Fredrik Malmberg, Giovanni Milotta, Sonia Nardin, Stefano Panzera, Andrea Quadri, Anna Rhodin, Mats Rydström, Daniel Sjöberg, Leonardo Tufaro, Karl-Gunnar Törnkvist and Dan Weinholt.

References

1. Radio-frequency arrangements for fixed service systems, Recommendation ITU-R F.746-9, Geneva, Switzerland, 2007.
2. Ericsson Annual Report 2010, Stockholm, Sweden, March 2011. http://www.ericsson.com/thecompany/investors/financial_reports/2010/annual10/sites/default/files/Ericsson_AR_2010_EN.pdf
3. Recommended guidelines for the accommodation and assignment of multimedia wireless systems (MWS) and point-to-point (p-p) fixed wireless systems in the frequency band 40.5-43.5GHz, ECC recommendation (01)04 (revised), Rottach-Egern, Germany, February 2010.
4. Radio frequency channel arrangements for fixed service systems operating in the bands 71-76GHz and 81-86GHz, ECC recommendation (05)07 (revised), Dublin, Ireland, 2009.
5. J. Hansryd, P-E Eriksson, High-speed mobile backhaul demonstrators, Ericsson Review, 2/2009. http://www.ericsson.com/ericsson/corpinfo/publications/review/2009_02/files/Backhaul.pdf
6. Propagation data and prediction methods required for the design of terrestrial line-of-sight systems, Recommendation ITU-R P.530-13, Geneva, Switzerland, October 1, 2009.
7. Larsson, P., Lattice array receiver and sender for spatially orthonormal MIMO communication, Vehicular Technology Conference, 2005. VTC 2005-Spring. 2005 IEEE 61st, vol.1, pp. 192-196, May 30-June 1, 2005.
8. Bohagen, F., Orten, P., Oien, G. E., Construction and capacity analysis of high-rank line-of-sight MIMO channels, Wireless Communications and Networking Conference, 2005 IEEE, vol.1, pp. 432-437, March 13-17, 2005.