



ENGINE 2.0 Training Programs

Package Description



Table of Contents

1	Introduction	3
2	Why invest in ENGINE Training?	3
3	What's in the ENGINE Training Package?.....	4
4	Fundamentals - Datacom.....	5
5	Fundamentals – ENGINE Integral Network.....	8
6	Fundamentals – ENGINE Access Ramp	9
7	Network Operation – ENGINE Integral Network	10
8	Network Operation – ENGINE Access Ramp	26
9	Network Development – ENGINE Integral Network	27
10	Business Management – ENGINE Integral Network.....	29
11	Business Management – ENGINE Access Ramp.....	32
12	Business Management – ENGINE Multi Media	33
13	How Do We Deliver?	35
14	Prerequisites	36
15	Related Services	36

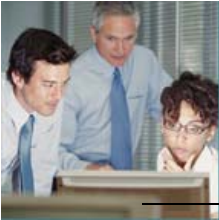

1 Introduction

This revision of the document emphasises training available within the ENGINE Solution on the Access, Core and Management Systems on current and available releases.

Ericsson has developed an extensive competence development learning portfolio to satisfy the competence needs of our customers in all situations and at all times – from exploring business opportunities, to expertise required for operating a network. The training has been developed to offer clearly defined, yet flexible training paths to target specific technical and business areas within your organization using blended learning – from traditional classroom teaching, to learning off the web for efficient, cost effective and highly successful results.

The ENGINE Training Package is a group of training courses, to build up competence when moving into the new Multi Service technology solutions.

2 Why invest in ENGINE Training?

At Ericsson, we've worked with hundreds of operators and Service Providers worldwide, and we are in a strong position to help. As a leader in developing industry standards for technology and products, we have structured our training packages around your needs, from basics to more advanced operations. Ericsson can identify your training needs and then select the right training package to provide the competencies required for a successful and profitable future.

Benefits

- **Faster time to revenue**

Task orientated, targeted and blended training to ensure staffs is operational in less time

- **Cost efficiency**

Blended learning for both time and cost efficiency. Lower operational costs provided by task oriented training

- **Increased performance/less churn**

Efficient processes achieved by skilled and competent staff

- **Minimal risk**

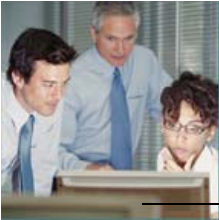

Ericsson's vast industry knowledge and experience is available through appropriate training

- **Organizational effectiveness**

Clear and continuous training strategies to motivate staff and provide opportunities for long term business success

3 What's in the ENGINE Training Package?

The ENGINE training offers a number of training courses ranging from how to explore the business opportunities to how to run the network, and focusing on target groups within different work areas of an operator's organization. For each work area we present standard training flows that match the currently defined job tasks. Continuous development of learning products within the ENGINE area is happening. Therefore the content and length of the learning products can be changed.

The course flows are focusing on following work areas:

- Fundamentals
- Network Operation
- Network Maintenance
- Network Development
- Customer Care
- Business Management

To ease the use of this document, the courses contained in the course flows are abbreviated, reflecting the type of course and/or methodology. The meaning of each abbreviation is given in the following:

- Instructor-Led Training (ILT)
- Web Based Learning (WBL)
- Multimedia Based Learning (MBL)
- Streaming Video (SV)
- Task Oriented Learning (TOL)

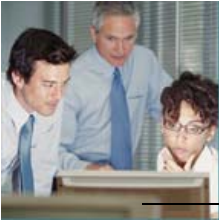

4 Fundamentals - Datacom

4.1 Datacom Technology Fundamentals

4.1.1 ATM Fundamentals (FAY 113 44)

The ATM Fundamentals training flow targets all technical personnel requiring knowledge on the Asynchronous Transfer Mode (ATM) principles. This flow covers all protocols supported, cell formats, creating of circuits and connections to enable ATM network traffic and ATM internetworking. The evolution and trends of ATM networking and alternative technologies including IP and Frame Relay as well as multi-service traffic types and quality of service (QoS) is discussed.

4.1.1.1 Main Learning Objectives

1. Understand the purpose of implementing ATM as the core network technology in the fixed and mobile networks.
2. Understand ATM protocols, QoS, as well as interworking with other technologies.
3. Understand why ATM is widely used to carry IP traffic.
4. Understand advantages and problems with ATM and IP interworking.
5. Understand the basics of the different protocols and traffic types used as well as how QoS is achieved.

4.1.1.2 Prerequisites

Students participating in the ATM Fundamentals flow shall have attended the Datacom Networking course listed below or have equivalent knowledge.

4.1.1.3 Training Flow

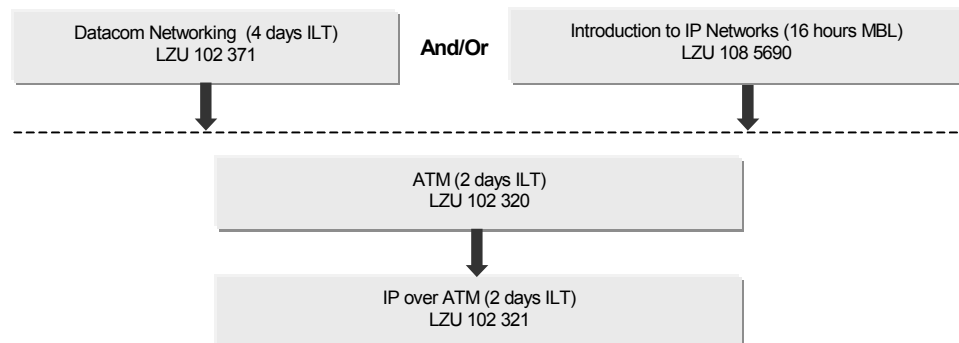

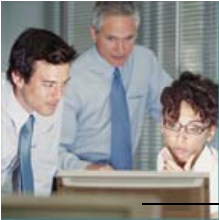

4.1.2 Introduction to IP Networks, WBL (FAB 102 1313)

This is a complete Web Based Learning flow that provides a comprehensive introduction to the underlying principles of data communications. The flow is integrated into the IP Fundamentals flow FAY 113 45 and contains information on;

How a PC communicates with other devices and networks, modern LAN and WAN technologies and concepts, the TCP/IP protocol suite, mobile network technologies, network architecture and applications and the management of data networks.

This flow also serves to introduce topics that will be covered in more detail in further Ericsson courses.

4.1.2.1 Main Learning Objectives

1. Describe how to connect a PC to a datacom network
2. Explain the basics of networking, Local Area Networks (LAN) and the Ethernet Standard
3. Describe Wireless Local Area Networks (WLAN)
4. Describe the basic concepts of IP networking
5. Describe the basic concepts of IP internetworking
6. Describe how to use the network and describe IP network applications
7. Explain the TCP/IP data communications architecture
8. Understand fixed network connections: access networks
9. Understand the basic concepts of mobile access
10. Describe the technologies in the core network
11. Define core network architectures
12. Understand network operation and maintenance

4.1.2.2 Prerequisites

There are no prerequisites for this WBL flow.

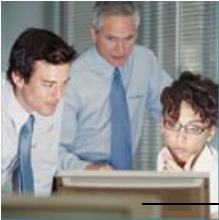

4.1.2.3 Training Flow

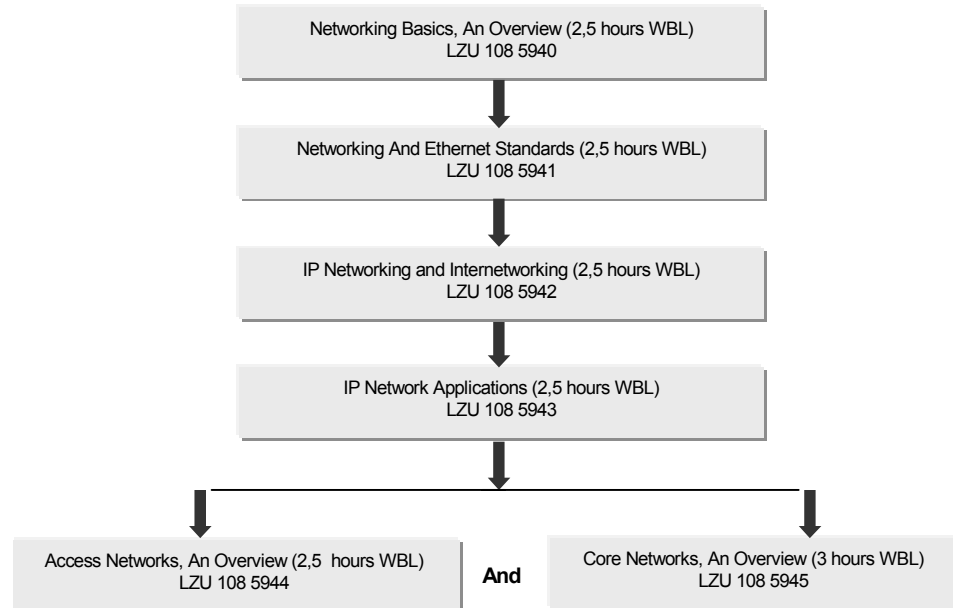

4.1.3 IP Fundamentals (FAY 113 45)

The IP Fundamentals training flow targets all technical personnel requiring knowledge on the TCP/IP protocol suite describing IP addressing principles and the purpose and operation of different protocols such as IP, TCP, UDP, ICMP, ARP. The flow gives a short historical introduction to the technology but the focus is mainly of the different protocol structures and transfer mechanisms. Practical networking exercises are included to prepare participants for real life challenges. Throughout the course, hands-on labs are used to pinpoint important aspects of theory sessions.

4.1.3.1 Main Learning Objectives

1. Understand the principles of the TCP/IP protocol suite (IP, TCP, UDP, ICMP, ARP, RIP and OSPF)
2. Describe IP addressing principles
3. Understand the advantages and disadvantages of LAN switches and routers
4. Know where to use LAN switches and routers in a networking environment.

4.1.3.2 Prerequisites

Students participating in the IP Fundamentals flow shall have attended the Datacom Networking course listed below or have equivalent knowledge.

Datacom Networking, LZU 102 371

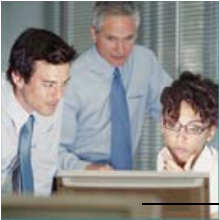

4.1.3.3 Training Flow

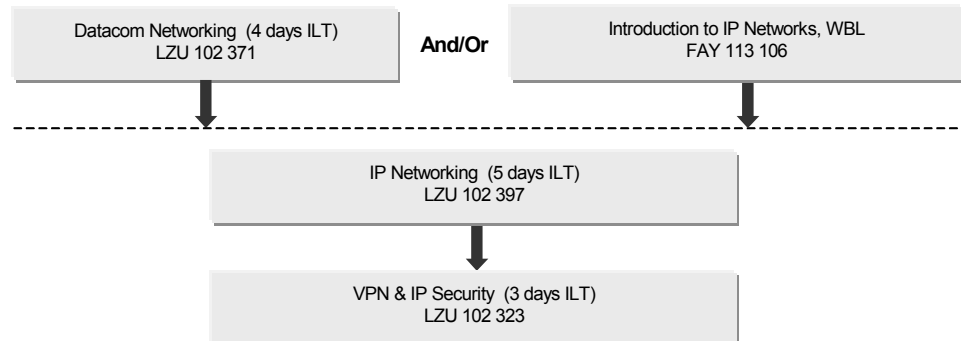

5 Fundamentals – ENGINE Integral Network

5.1 ENGINE Integral Network Fundamentals

5.1.1 ENGINE Core Fundamentals (FAY 113 47)

This training flow introduces the student to the ENGINE core concept and the node elements within each of the ENGINE Multi-Service network solutions. It deals with the features and benefits of the ENGINE Core solutions and the market drivers that makes ENGINE worth investing in. The future of ENGINE solutions and core technologies is also covered as well as the management system supporting the ENGINE Integral solutions. It describes how ATM is used to transmit voice over the core network and shows different traffic scenarios. After participating in this flow the student will have a good understanding of the features and advantages that is included in the ENGINE Integral solutions.

5.1.1.1 Main Learning Objectives

1. Understand why an operator would choose ENGINE.
2. Understand how IP, ATM and MPLS are used in the connectivity network for ENGINE.
3. Describe the basic functions and network elements of ENGINE Softswitch solutions: ENGINE Integral Network, ENGINE Multimedia Network and Open Network Gateway (ONG).
5. Explain the basics of the management system MN-OSS 5.0.

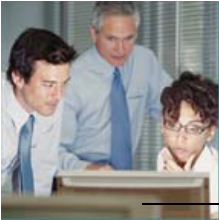

5.1.1.2 Prerequisites

Students participating in this flow shall have general good knowledge of Telecommunication Networks equivalent to the course Understanding the new Telecom, LZU 107 106.

5.1.1.3 Training Flow

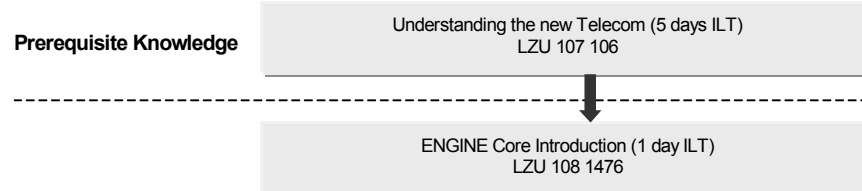

6 Fundamentals – ENGINE Access Ramp

6.1 ENGINE Access Ramp Fundamentals

6.1.1 ENGINE Access Ramp Fundamentals (FAY 113 46)

This training flow introduces the student to the ENGINE Access Ramp concept and the node elements within each of the Access network solutions. It covers the Broadband as well as the Narrowband solution and the components included. The training flow deals with the features and benefits of the ENGINE Access solutions and the market drivers that make ENGINE Access Ramp worth investing in. The future of ENGINE Access solutions is also covered as well as the management system supporting the access solutions. After participating in this flow the student will have a good understanding of the features and advantages that is included in the ENGINE Access Ramp Narrowband and Broadband solutions.

6.1.1.1 Main Learning Objectives

1. Outline the role of ENGINE Access Ramp in the ENGINE concept.
2. List the services offered by ENGINE Access Ramp.
3. Understand what DSL is.
4. Describe the components of ENGINE Access Ramp.
5. Describe possible network configurations and product packages.
6. Identify how management is carried out in the access network.

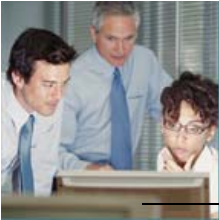

6.1.1.2 Prerequisites

Basic Telecoms knowledge, subscriber stage knowledge in AXE and Datacoms knowledge to the level of:

Datacom Networking, LZU 102 371

6.1.1.3 Training Flow

Prerequisite Knowledge

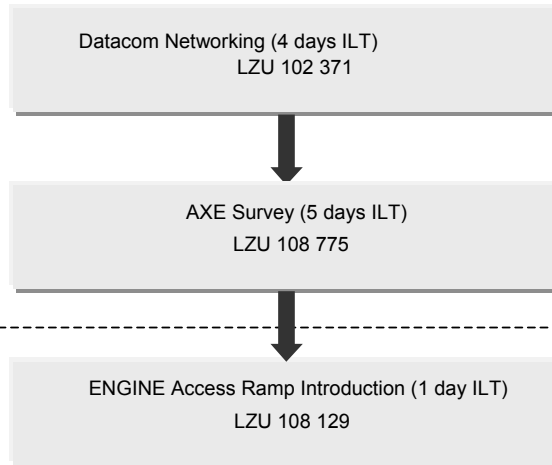

7 Network Operation – ENGINE Integral Network

7.1 Network Surveillance

The Management system for ENGINE Core solutions is called MN-OSS (Multi Service Networks Operating Support System) and is applicable for all ENGINE Integral Networks. These training flows are divided into two different tracks one for AXE Classic network management and one for the Telephony over ATM (ENGINE Integral) solution management. This is due to the fact that the AXD 301/305 nodes only operate in the ENGINE Integral solutions hence the AXD specific management applications are only included in the Telephony over ATM flow and the AXD 301/305 specific courses.

The ENGINE management training flows gives several training path options based upon the management systems and tools that are to be handled. If specific tools or applications will be handled by separate job categories the courses covering these areas can easily be identified and taken out of a training flow. There are courses to support personnel dealing with only AXE

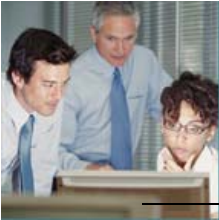

related network surveillance, AXD 301/305 related network surveillance as well as training for personnel that will cover network surveillance for the Telephony over ATM solution covering both nodes.

The flows can be customized to suite the operators specific needs for training on certain applications.

7.1.1 MN-OSS Operation Telephony over ATM/AXE, Network Surveillance (FAY 113 51)

This training flow focuses on Network Management on an AXE network and AXE nodes as well as on the nodes included in the Telephony over ATM solution ENGINE Integral, which includes AXE and AXD 301/305. Personnel that will deal with network surveillance of the ENGINE Integral Network will gain knowledge on the applications and features listed below.

Applications/features included are:

NSM - Network Surveillance Multiservice (Included is Alarm Mediation Device)

ACT – AXD Configuration Tool

File Handling

ALEX

WinFIOL

TPS

TSC

In addition, in the optional course Using the FMX tool, LZU 108 5148, the student will gain knowledge about the purpose of FMX (Fault Management Expert) regarding the contents, functionality and the connection to other applications in the management system. The course discusses the use of FMX as a tool to develop and maintain an expert system for intelligent alarm handling, that is, to embody and apply expertise knowledge in rules which are put into FMX modules. The main focus will be on how to create, develop and administrate FMX modules and rules.

The training courses in this flow include both theory sessions as well as practical exercises that will give the students knowledge on how to use the applications in live network and fully benefit from the functionality contained.

7.1.1.1 Main Learning Objectives

Describe the functionality of the mandatory MN-OSS applications used in the Telephony over ATM and AXE support package

1. Describe the functionality of the mandatory MN-OSS applications used in the Telephony over ATM and AXE support package
2. Use Element Management Tools to communicate and configure AXD/AXE Network Elements

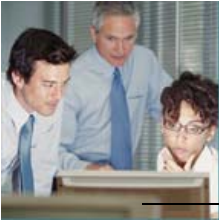

3. Transfer files between MN-OSS & AXE Network Elements
4. Design and execute OPS scripts
5. Describe and use the Command File Language (CFL) used to develop Command Files in OPS
6. Handle alarms and configure the way they are presented
7. Gather and present statistical information from the AXD based network elements, and to set thresholds to generate pro-active alarms
8. Give a general description of ACT and its purpose
9. Perform the most common configuration, software management and user management tasks for multiple AXD network elements

For the optional course on the FMX application:

10. Describe what FMX is
11. Use the FMX user interfaces and tasks
12. Create and maintain FMX modules
13. Use tools for rule design
14. Use more advanced features and rule implementation

7.1.1.2 Prerequisites

Students participating in this training flow shall have basic Telecommunication knowledge and should have attended the course AXE Survey – LZU 108 775 or have equivalent knowledge. For the course Using the FMX tool, the students should have some experience in object-oriented programming.

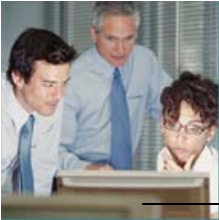

7.1.1.3 Training Flow

Prerequisite Knowledge

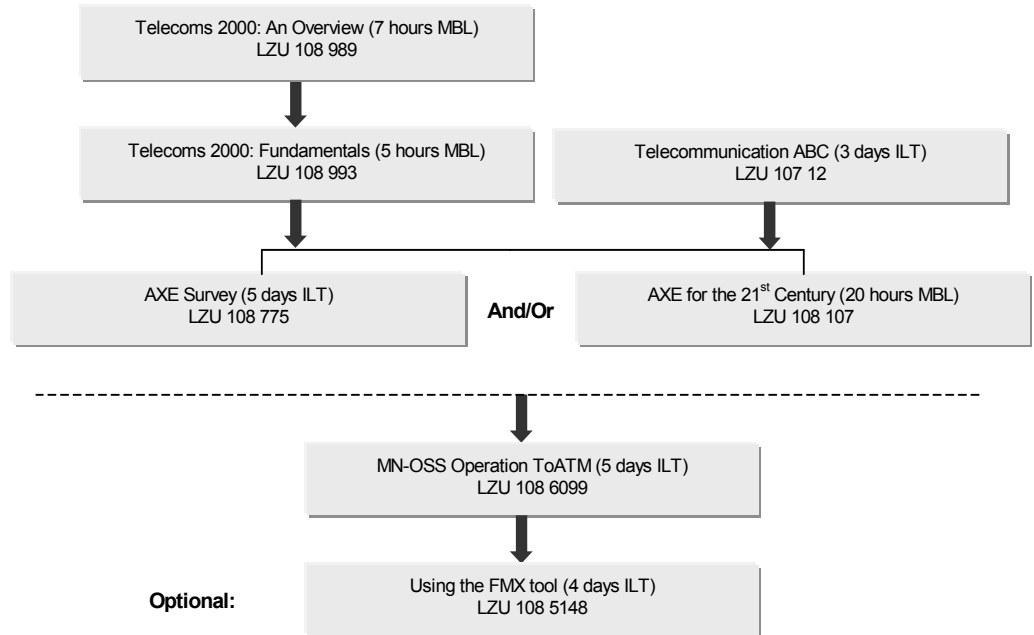

7.1.2 MN-OSS (AXD 301/305) Network Surveillance (FAY 113 53)

This training flow will give the students knowledge on how to operate the Network Management applications included in the Multi Service Networks Operation Support System supported by the nodes AXD 301/305. This flow covers the 5.0 release of the management system and is targeted towards operators using the AXD 301/305 nodes in an ENGINE Integral network transporting telephony over ATM. The applications included are:

NSM – Network Surveillance Multi Service (included is AMD – Alarm Mediation Device)

PMR – Performance Monitor

These applications handle establishment of connections, monitoring of network topology as well as monitoring of alarms and events. Performance measurements and advanced configuration features are also functionality included in these applications. The flows exist of both theory sessions and practical exercises.

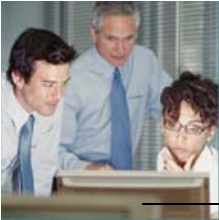

7.1.2.1 Main Learning Objectives

1. Understand the basics and functionality of the applications NSM, PMR and AMD.
2. Understand element discovery on the IP network
3. Understand SNMP configuration.
4. Manage an ATM Network Topology.
5. Configure permanent connections on an AXD 301/305 switch.
6. Understand how to set up performance measurements on the AXD 301/305.
7. Understand performance data and the database.
8. Understand the alarm functions and the Alarm Gateway handler.
9. Operate the performance presentation manager
10. Perform backup and restore handling, patch distribution handling and cloning.

7.1.2.2 Prerequisites

Students participating in this flow shall have attended the course Telecommunications ABC LZU 107 12 or have equivalent knowledge.

7.1.2.3 Training Flow

Prerequisite Knowledge

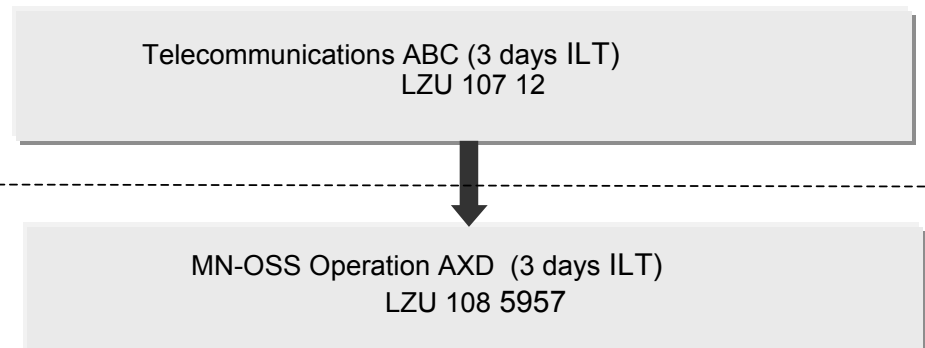

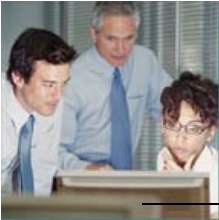

7.1.3 MN-OSS System Administration, Network Surveillance (FAB 102 1340)

This flow will give the student knowledge about administration of the MN-OSS R5 system. After the course the students will be able to handle the standard maintenance of an up-and-running system.

The focus in the flow is the MN-OSS UNIX platform and the student will gain thorough knowledge about how to handle processes, errors and authority in the MN-OSS system. The flow also covers fault management and network element connections and consists of modules with mostly practical sessions (task-oriented) with complementary theoretical parts. In the practical sessions the students will be presented with the tasks required to administer and maintain an MN-OSS system. The students solve the tasks on a training system, using the on-line documentation. The tasks are always concluded by an instructor lead discussion.

7.1.3.1 Main Learning Objectives

1. Describe the overall structure of an OSS system.
2. Handle Authority Administration in the OSS system
3. Manage processes in the OSS system
4. Use and describe the main components in the fault management system
5. Set up connections to network elements
6. Perform standard maintenance in the OSS system

7.1.3.2 Prerequisites

The participants should be familiar with MN-OSS application systems handling to the level of the following courses:

MN-OSS Operation, AXE	LZU 108 5658
MN-OSS Operation, AXD	LZU 108 5957

7.1.3.3 Training Flow

Prerequisite Knowledge

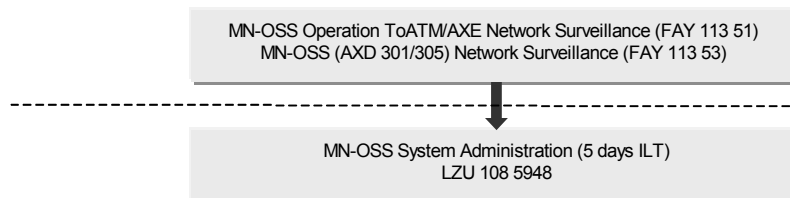

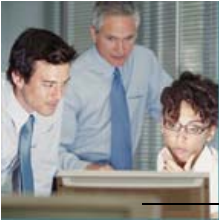

7.2 Network Configuration

7.2.1 AXD 301/305 4.0 Network Configuration (FAY 113 56)

This flow will give the student knowledge on the principles of ATM core networks and the functionality of the AXD 301/305 core switch applicable to release 4.0 of the system. The flow is intended for technical personnel that will configure connections in the ATM network and configure the different features supported by the AXD 301/305 nodes. This flow consists of theory sessions followed by practical exercises to achieve knowledge on how to operate the system.

7.2.1.1 Main Learning Objectives

1. Understand how to configure the AXD 301 switch. This will include the configuration of permanent connections, soft permanent connections and switched connections with all signalling protocols supported. Configuration of IP communication, performance management, charging output, software maintenance and network synchronisation.
2. Perform basic troubleshooting as well as be able to restart the system in several ways.
3. Know how to perform software upgrades and install patches, create backups, logs and batchjobs.
4. Perform necessary maintenance of the switch, fan replacement and board replacements.

7.2.1.2 Prerequisites

Students attending this flow shall have attended the ATM Fundamentals flow or have equivalent knowledge.

7.2.1.3 Training Flow

Prerequisite Knowledge

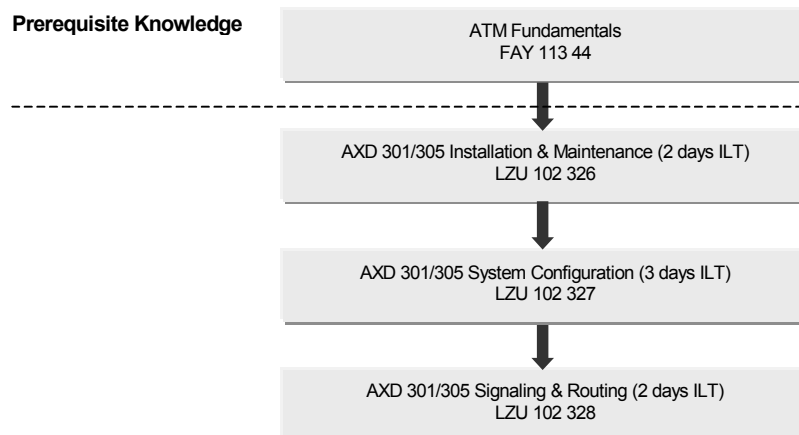

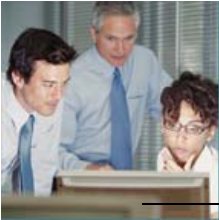

7.2.2 AXE Network Configuration (FAY 113 50)

The AXE Exchange together with an AXD 301/305 switch forms the Telephony server in the ENGINE Intergral networks and this flow is therefore a prerequisite flow to the ENGINE network configuration courses.

On completion of this training flow the participants will have knowledge of the Operation & Maintenance activities performed in an AXE Exchange and an understanding of the most frequent types of work. The flow will also give more advanced training for Operation & Maintenance staff. The Hardware Maintenance necessary for the AXE will be addressed and this part focuses on Maintenance personnel. The flow provides the participants with a deep understanding of the Operation & Maintenance activities to be carried out in an AXE exchange.

The Automated O&M using OPS course is intended to train the students in using the functions of the Operation Procedure Support (OPS) tool within an MN-OSS system. The main focus is to give the students knowledge about how to use OPS to create, edit and debug command files for advanced command handling. The OPS command files (Scripts) can take care of routine- and time consuming jobs and the network operator can instead work with more important tasks.

7.2.2.1 Main Learning Objectives

1. Basic O&M activities in AXE & Exchange Handling Basics
2. Communication with the system & Hardware Orientation.
3. Connection to Group Switch.
4. Size Alteration.
5. Configuration of IOG and hardware structure
6. Command and File Handling & System Backup Handling.
7. Route Analysis & Traffic Measurement
Service Assessment
8. Charging Statistics & Charging Output & Traffic
Measurement
9. Test of trunk lines and Subscriber lines.
10. Branching
11. Group Switch Maintenance & APZ Maintenance.
12. Subscriber Line Supervision Alarm& Subscriber Switch
Hardware Alarms

For the OPS course:

13. Describe and use OPS both as a development tool and part of an expert system
14. Describe and use the Command File Language (CFL) used to develop Command Files in OPS
15. Creating of advanced command files

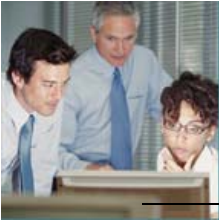

7.2.2.2 Prerequisites

Students participating in this training flow must have attended the course AXE Survey, LZU 108 775 or have equivalent knowledge. Experience in handling the basic MN-OSS applications is recommended, see for example MN-OSS Operation Telephony over ATM/AXE, Network Surveillance (FAY 113 51).

7.2.2.3 Training Flow

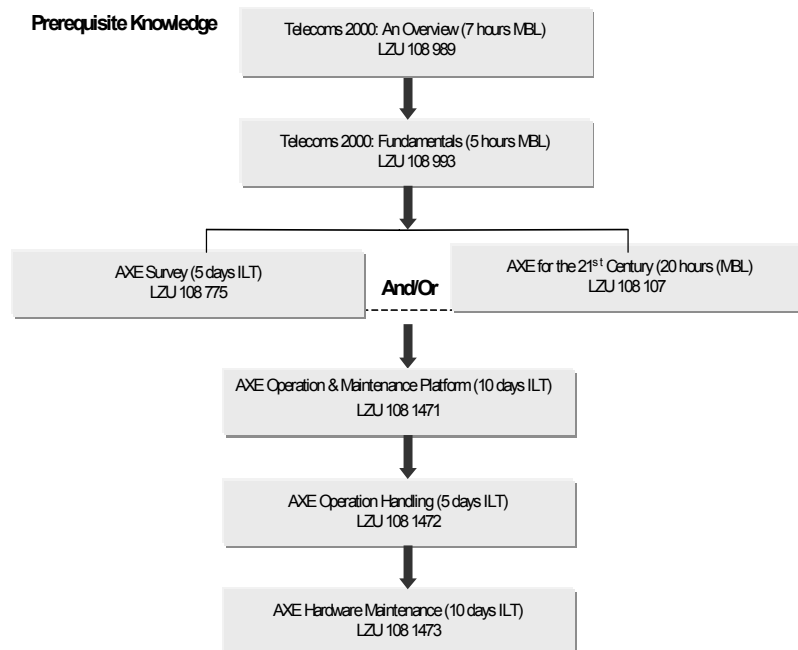

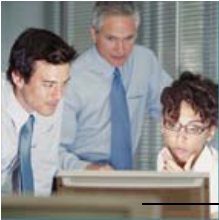

7.2.3 APG 40 Configuration (FAY 113 59)

The APG 40 will replace IOG20 and APG 40 is included as the I/O system in all Ericsson major System Solutions such as ENGINE, WCDMA Systems and GSM that have been rolled out worldwide.

This training flow introduces students to the APG 40 node and its functionality. The students will carry out operational and maintenance tasks on the Platform and the APIO application. The flow consists of 4 practical courses that target different functions.

The first course is targeted towards Operation and maintenance personnel with the following main parts included: Introduction to APG 40, APG 40 Hardware and Software, ACS Functions, Services and Facilities, APIO including FMS and MCS. The course will also give the students knowledge on how to operate and benefit from the STS application in APG40

The Installation and Configuration course is targeted towards System administrators and will also contain some installation activities.

The following main parts are included: Start up of APG 40, Installation of APIO, Description of the APG 40 Domain, Domain Handling on APG 40 and Migration from IOG 20 to APG 40.

FOS (Flexible Output System) is responsible for the formatting of the charging information into Toll Ticketing (TT) and to distribute the formatted data to Operations Systems such as Billing Centers or other Post Processing Systems. The FOS course explains how to perform: General Operation of FOS in APG40; verification of the transfer of billing data from AXE to APG40; backup of billing data; FOS parameter configuration and handling of FOS alarms.

The Recovery is targeted towards the maintenance and support staff.

The following main parts are included: Perform a Health Check of an APG40 System, Create a Trouble Report, Make a proper backup of the APG40 System, Perform the AP System Disaster Recovery OPI to restore an APG40 System, Do a Quorum Restore on the APG40 System and Initiate a data disk restore on the APG40 System

This is an instructor-supported training flow with focus on practical exercises.

7.2.3.1 Main Learning Objectives

For the Operation & Maintenance and Installation and Configuration work area:

1. Know how to connect to the APG 40
2. Understand how to connect to the APG 40, using a local console, Telnet (WinFiol) and PcAnywhere.
3. Be familiar with the hardware on APG 40

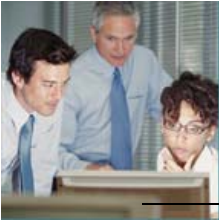

4. Understand the different software layers in APG 40
5. Be able to use the graphical user interfaces
6. Perform function change of AP
7. Understand and use APIO application
8. Know how to start up the APG 40
9. Upgrade and install software on the APG 40
10. Understand domain handling in APG 40
11. Migrate to APG from IOG
12. Collect statistics using STS
13. Configure the STS on AP to request counter data from the CP
14. Give an overview of STS on APG40 and describe the main functions
15. Describe the main functions of the STS
16. Configure the database and start the transfer of counter values Know how to connect to the APG 40

For the FOS course:

1. Operate and maintain FOS on the Adjunct Processor
2. Use different tools on the Adjunct Processor and FOS
3. Recognize and Solve the most frequent error situation in FOS
4. Identify and use the correct OPI to solve the Alarm
5. Configure the Flexible Formatter

For the Recovery procedures course

1. Perform a Health Check of an APG40 System
2. Create a Trouble Report
3. Make a proper backup of the APG40 System
4. Perform the AP, System Disaster Recovery OPI to restore an APG40 System
5. Do a Quorum Restore on the APG40 System
6. Initiate a data disk restore on the APG40 System

7.2.3.2 Prerequisites

Students participating in this training flow should have knowledge of Windows NT or Win2k and shall have attended in the following courses or have equivalent knowledge.

AXE Survey, LZU 108 775

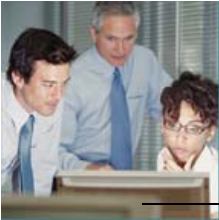

7.2.3.3 Training Flow

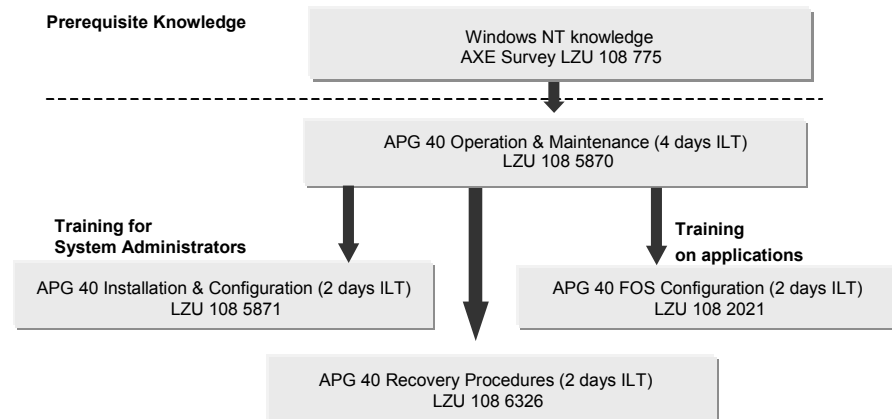

7.2.4 AXE Enabler Network Configuration (FAY 113 60)

The purpose of this training flow is to provide the participants with the knowledge about the functionality in AXE Enabler 1.0 which is the new software used in ENGINE Integral networks. The differences between Local 7.2/TL4.2/TG5.2 and AXE Enabler 1.0 modern/classic will be the main topics described but even the differences from earlier product lines will be mentioned.

7.2.4.1 Main Learning Objectives

1. Describe the node types supported by the AXE Enabler 1.0.
2. Describe the main differences between L7.2/TL4.2/TrG 5.2 and AXE Enabler 1.0 Classic and Modern.
3. Describe the main hardware changes in HWM1.5 platform and the support of large switches.
4. Understand the main functions and features in APZs supporting Enabler 1.0.
5. Describe the IPN network solution.
6. Understand the handling of AS Parameters Using DBS Commands
7. Understand the Remote connection of Internet Access Server
8. Understand how comprehensive network signalling is realised via inclusion of ET155, SS7, PRA and V5.x signalling using signalling terminals on RPG3
9. Understand the Engine Access Ramp functions.

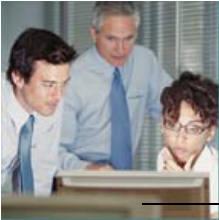

10. Describe the AXE Enabler 1.0 functions in an EIN 2.0 network and migration support towards EIN2.0.
11. Describe the ported products to AXE Enabler 1.0 GAS

7.2.4.2 Prerequisites

The participants should have attended the course Local 7 to Local 7.2 Delta, which is handling the Translocal 4.2 as well, or have equivalent knowledge in operation of the Local 7.2/ Translocal 4.2 application.

7.2.4.3 Training Flow

Prerequisite Knowledge

Local 7 to Local 7.2 Delta (2 days ILT)
LZU 108 5501



AXE Enabler 1.0 Delta (3 days ILT)
LZU 108 5933

7.2.5 APZ 212 30/33 Network Configuration (FAY 113 61)

This training flow deals with the APZ 212 30/33 and the included functionality. The difference between the APZ 212 20 and the APZ 212 30/33 is described both in hardware and in functionality. The flow consists of theoretical lessons and practical exercises.

7.2.5.1 Main Learning Objectives

1. Describe the hardware structure of APZ 212 30/33 and the boards housed in the magazines and the cables in APZ 212 30/33
2. Name and explain the new commands
3. Explain what is meant by "self identifying hardware."
4. Perform an extension of both Data Store and RPH Magazine.
5. Perform cash memory loading for both the Data Store and the Program Store.
6. Describe program execution in APZ 212 30 and 212 33.

7.2.5.2 Prerequisites

The participant should be familiar with handling of older APZ 212 versions.

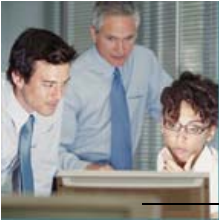

7.2.5.3 Training Flow

Prerequisite Knowledge

Knowledge of older APZ 212 versions



APZ 212 30/33 Delta (1 day ILT)
LZU 108 1446

7.2.6 ENGINE Core Signalling Network Configuration (FAB 102 1345)

This training flow is designed to give the participant an overview of signaling technologies used to manage and control voice calls in the Core Networks for ENGINE Integral Network (EIN) 1.0.

7.2.6.1 Main Learning Objectives

1. Explain the structure of the Signaling System No. 7.
2. Explain the different functions of Signaling System No. 7 in the GSM- and WCDMA Systems Core Network up to CN2.0.
3. Explain the different functions of Signaling System No. 7 in the ENGINE Integral Network EIN 1.0.
4. Be familiar with user plane protocol stacks.
5. Be familiar with the signaling on the G- and I-interfaces.
6. Explain the H.248/GCP and BICC signaling in detail.
7. Explain the function of bearer signaling.
8. Explain the BSSAP signaling in detail.
9. Explain the RANAP signaling in detail.
10. Explain the signaling between AXE and AXD 301 Mediation Logic (ML) in ENGINE on a high level.

7.2.6.2 Prerequisites

Students attending this training flow shall have participated in the ENGINE Core Fundamentals flow.

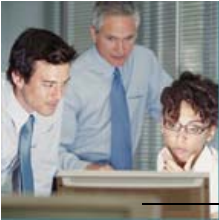

7.2.6.3 Training Flow

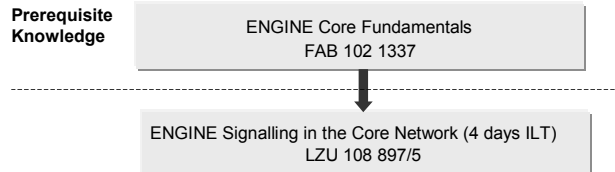

7.2.7 ENGINE Integral Network Configuration (FAY 113 63)

This training flow is targeted towards Operation & Maintenance as well as support personnel that will configure, operate and maintain the ENGINE Integral networks. The same training is applicable for both ENGINE Integral 1.0 and 2.0 networks. The flow covers knowledge regarding how to configure and verify the functionality of the ENGINE Integral network as well as setting up connections and deal with alarms and faultfinding. It deals with necessary configuration in all existing nodes of the network in order to establish the communication. It also contains the verification needed to secure a complete and successful configuration of the entire network and the access node interfaces supported.

The Operation and Maintenance course is suitable for anyone who will deal with daily activities relating to the operation of an Integral based ENGINE network, monitoring and solving alarms. The Faultfinding course will give the student more detailed knowledge on how to find faults in the network according to the guidelines. The faultfinding methods will help participants to locate the faults, which will lead to a more specified Trouble Reports.

This flow is of TOL nature, which means that the focus is on practical exercises that will be performed on the existing features and functionality.

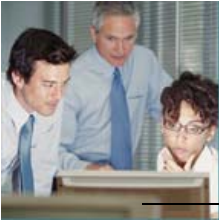

7.2.7.1 Main Learning Objectives

1. Know all network elements of an ENGINE Integral Network and understand how traffic is handled between the elements.
2. Understand the HW and SW implementation in EIN 1.0/2.0.
3. Establish CP communication between the Call Control Function (CCF) and the Mediation Logic (ML), and know what alarms that are connected to this interface.
4. Configure the interconnect interface (IC) between the CCF and the MGW(IC), and know what alarms that are connected to this interface.
5. Configure the MGW control interface between the ML and the MGW, using H.248, and know what alarms that are connected to this interface.
6. Configure the Bearer Independent Call Control (BICC) interface between Telephony Servers (TeS) belonging to different domains, and know what alarms that are connected to this interface.
7. Configure at least two of the ETSI-ISUP, ANSI-ISUP, V5.2, ETSI- PRA, EAR and RSS accesses, and know what alarms that are connected these accesses.
8. Verify the configuration by making test calls, using the different accesses configured.
9. Make call-path tracings in CCF, ML and MGW.
10. Use faultfinding methods for the EIN to locate and solve faults.
11. Trace calls and connections through the EIN.
12. Understand recovery and reliability in the EIN.
13. Understand how to use the different counters for measurement in the EIN.

7.2.7.2 Prerequisites

Students participating in this flow shall have attended the following courses or have equivalent knowledge.

ENGINE Core Fundamentals
AXD 301/305 Network Configuration
AXE Network Configuration

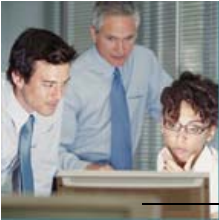

7.2.7.3 Training Flow

Prerequisite Knowledge

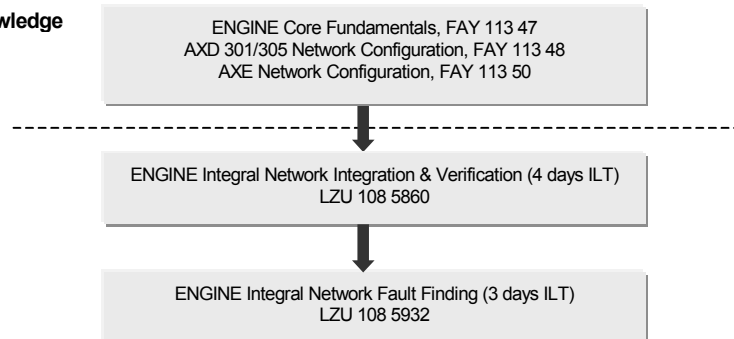

8 Network Operation – ENGINE Access Ramp

8.1 Network Configuration

8.1.1 ENGINE Access Ramp Narrowband, Network Configuration (FAY 113 64)

This training flow is a modular learning product on how to perform Operation & Maintenance activities on an ENGINE Access Ramp for AXE application. The flow is instructor-led and task-oriented. At the end of the course the student will be able to perform O&M activities on an AXE connected ENGINE Access Ramp.

This flow is intended for all personnel working with configuration, operation as well as maintenance of the system. The ENGINE Access Ramp flow for Narrowband requires AXE knowledge as a prerequisite.

8.1.1.1 Main Learning Objectives

1. Describe the general system structure of the ENGINE Access Ramp for AXE, its units and their basic functions
2. Describe the different signalling interfaces used and how V5 is used in ENGINE Access Ramp
3. Understand the difference between the ENGINE Access Ramp for AXE application and the ENGINE Access Ramp for V5.2 interface.
4. Verify control signalling on the CSP and the signalling on the V5.1 and TAU channels
5. Define a new AU PSTN in an existing Network Node, connect subscribers and take those into service

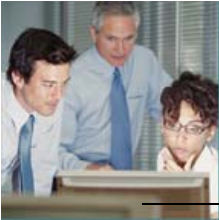

6. Define a new AU ISDN in an existing Network Node, connect subscribers and take those into service
7. Check for alarms and take correct actions
8. Describe the HW units of the TAU and their main uses
9. Describe the main software blocks used by TAU, including the blocks for the different TAU applications.
10. Carry out a function change of load module for a plug-in unit, from the IOG20 to the plug-in unit (AU orTAU).

8.1.1.2 Prerequisites

Students participating in this flow shall have attended the AXE Network Configuration flow or have equivalent knowledge.

8.1.1.3 Training Flow

Prerequisite Knowledge

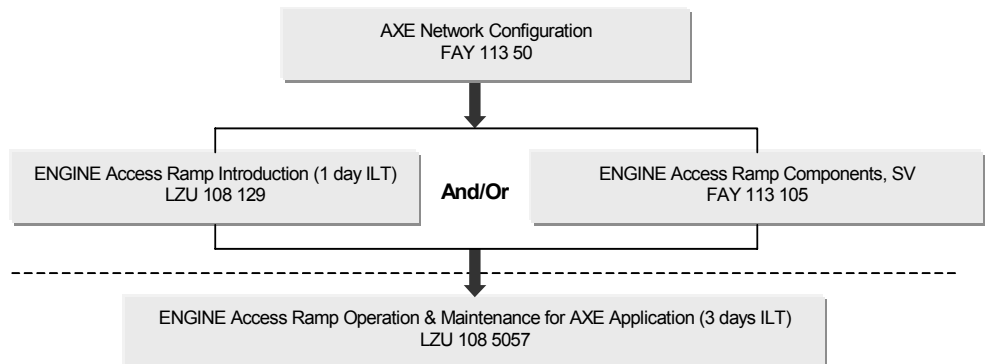

9 Network Development – ENGINE Integral Network

9.1 Core Network Node Dimensioning

9.1.1 ENGINE Integral Network Dimensioning (FAY 113 67)

This flow in the ENGINE Integral training is highlighting dimensioning of the network. It consists of a two-step training path for personnel working with planning and dimensioning aspects relating to the introduction of an ENGINE Integral Network. This flow gives the knowledge on how to build a network that meets the requested expectations.

The training flow emphasizes on a calculation model for dimensioning of an Engine Integral Network (EIN 1.0). The focus is especially on the Call Handling Capacity (CHC) and on board configuration in the associated Multi-Service

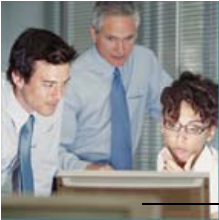

Gateways (MSG's) as well as on the Mediation Logic (ML). Furthermore it includes calculation of the call handling capacity in the Telephony Server (TeS). The flow contains presentations, exercises and cases in order to train the participants to handle the structuring, calculation and dimensioning of an EIN 1.0 network. The main target audience for this training is marketing and solution personnel with switching background.

9.1.1.1 Main Learning Objectives

1. Understand the voice and data traffic theory needed for the calculation and estimations of traffic volumes, distribution portions and switched calls/s to be applied in the further EIN 1.0 dimensioning calculation
2. Understand the main factors which have an direct impact of the dimensioning calculation as the traffic mix, traffic distribution flows, traffic complexity and processor workloads and related capacity limits for both MSG/MGW, ML and APZ 21233

Be able to calculate and dimension the EIN 1.0 network for different network environments, of boards and subracks for MSG/MGW, ML-IC as well as estimating the current processor loads for MSG/MGW, ML-IC and APZ 21233 in order to achieve a first preliminary network structure towards the final design and size of an efficient EIN 1.0 network.

9.1.1.2 Prerequisites

Students participating in this training flow shall have attended the following courses/flows or have equivalent knowledge.

ENGINE Core Fundamentals

9.1.1.3 Training Flow

Prerequisite Knowledge

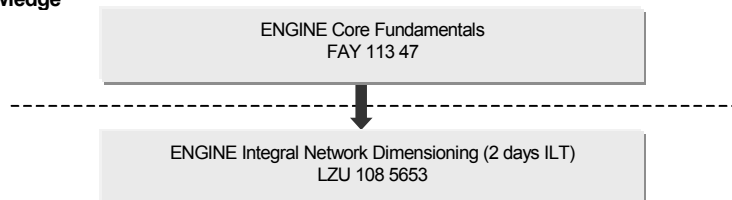

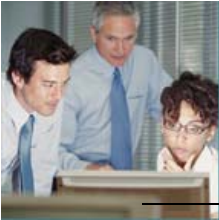

10 Business Management – ENGINE Integral Network

10.1.1 ENGINE Core Business Management (FAY 113 83)

This training flow introduces the student to the ENGINE core concept and the node elements within each of the ENGINE Multi-Service network solutions. It deals with the features and benefits of the ENGINE Core solutions and the market drivers that makes ENGINE worth investing in. The future of ENGINE solutions and core technologies is also covered as well as the management system supporting the ENGINE Integral solutions. It describes how ATM is used to transmit voice over the core network and shows different traffic scenarios. After participating in this flow the student will have a good understanding of the features and advantages that is included in the ENGINE Integral solutions.

10.1.1.1 Main Learning Objectives

1. Understand why an operator would choose ENGINE.
2. Understand how IP and ATM are used in the connectivity network for ENGINE.
3. Explain how ATM is used to transport voice in the connectivity network.
4. Describe the basic concepts of ENGINE Multi-Service network solutions: ENGINE Switched Network, ENGINE Bridgehead Network, ENGINE Integral Network and ENGINE Multimedia Network.
5. Describe the basics of the management system MN-OSS 5.0.

10.1.1.2 Prerequisites

Students participating in this flow shall have general Datacom and ATM knowledge equivalent to the ATM Fundamentals flow. They shall also have general AXE knowledge equivalent to the course AXE Survey, LZU 108 775.

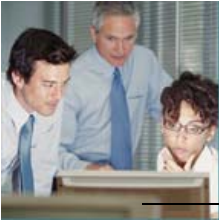

10.1.1.3 Training Flow

Prerequisite Knowledge

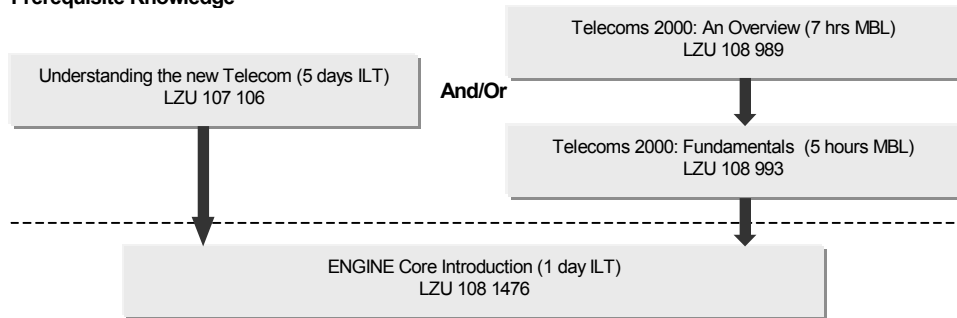

10.1.2 APG 40 Business Management (FAY 113 69)

This course introduces students to the APG 40 nodes and the functionality included. The students will get an overview of the possibilities of the APG 40. The course consists of the following main parts: Introduction to different I/O systems, the APG 40 build-up (HW and SW) and the user interface. It is an instructor-led theoretical learning product with, if possible, a demonstration on the system. This course does not go into the details of configuration parameters in APG 40.

10.1.2.1 Main Learning Objectives

1. Have knowledge about different I/O systems: IOG20, APG3x and APG40 and in which systems they can be used.
2. Be familiar with the performance of the APG40 in comparison to IOG20 and APG3x.
3. Have knowledge about the APG40 Hardware (LBB, RAID, and IPN/STOC).
Software
4. Have knowledge about the APG40 Software (LBB, APM, ACS, OCS, GOH, APIO, FOS/RDT, and STS).
5. Alarm System and APG system handling.
Connection to the APG 40
6. Have knowledge about the Local Craft Terminal (LCT).
7. Be able to describe how a user may access the AXE system via APG: pcANYWHERE, Telnet, WinFiol, AP-mode, CP-mode.

10.1.2.2 Prerequisites

Students attending this flow shall have participated in the following WBL courses.

Telecoms 2000, An Overview
Telecoms 2002 Fundamentals

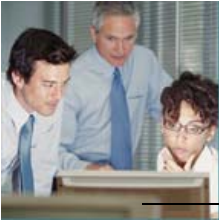

10.1.2.3 Training Flow

Prerequisite Knowledge

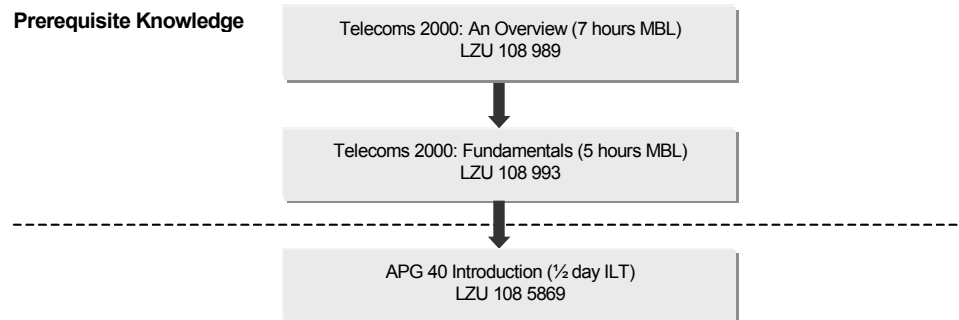

10.1.3 AXE 810 Business Management (FAY 113 70)

This flow is describing the market drivers behind AXE 810 and the main differences, on a high level. The differences described are between the older systems BYB 202 and HWM 1.3 (BYB 501) and the new AXE 810. This flow is aimed for operator planning for updates and/or expansions using the new AXE 810.

10.1.3.1 Main Learning Objectives

1. Describe the benefits of AXE 810
2. Understand the market and the drivers behind AXE 810
3. Describe the main improvements on a high level between BYB 202, HWM 1.3 and the new AXE 810
4. Account for differences in metrics such as floor space, power consumption and capacity.
5. Account for the main changes within APZ such as CP, RP, RPG, RPP and IO (APG40)
6. Account for the main changes in APT such as new magazines (GEM), ET155, TRA, ECP and Group Switch.

10.1.3.2 Prerequisites

Students participating in this training flow shall have attended the following courses/flows or have equivalent knowledge.

AXE Survey, LZU 108 775.

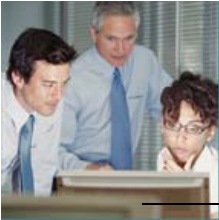

10.1.3.3 Training Flow

Prerequisite Knowledge

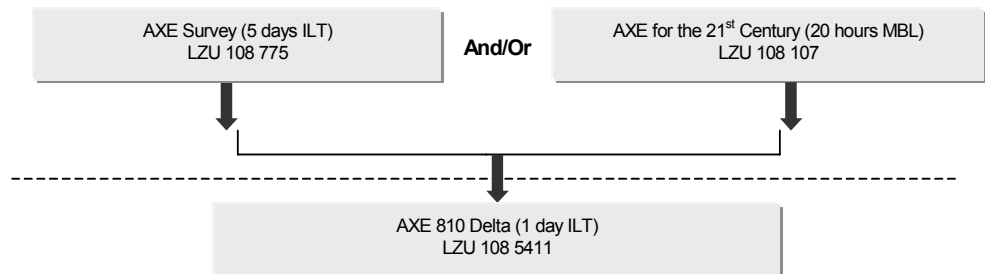

11 Business Management – ENGINE Access Ramp

11.1 Executive Officers, Managers, Financial Mangers, Marketing, Sales, Business Managers & Team Leaders

11.1.1 ENGINE Access Ramp Business Management (FAY 113 84)

This training flow introduces the student to the ENGINE Access Ramp concept and the node elements within each of the Access network solutions. It covers the Broadband as well as the Narrowband solution and the components included. The training flow deals with the features and benefits of the ENGINE Access solutions and the market drivers that make ENGINE Access Ramp worth investing in. The future of ENGINE Access solutions is also covered as well as the management system supporting the access solutions. After participating in this flow the student will have a good understanding of the features and advantages that is included in the ENGINE Access Ramp Narrowband and Broadband solutions.

11.1.1.1 Main Learning Objectives

1. Outline the role of ENGINE Access Ramp in the ENGINE concept.
2. List the services offered by ENGINE Access Ramp.
3. Understand what DSL is.
4. Describe the components of ENGINE Access Ramp.
5. Describe possible network configurations and product packages.
6. Identify how management is carried out in the access network.

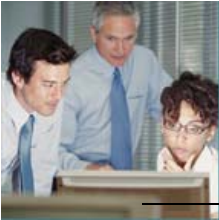

11.1.1.2 Prerequisites

Basic Telecoms knowledge, subscriber stage knowledge in AXE and Datacoms knowledge to the level of:

Datacom Networking, LZU 102 371

11.1.1.3 Training Flow

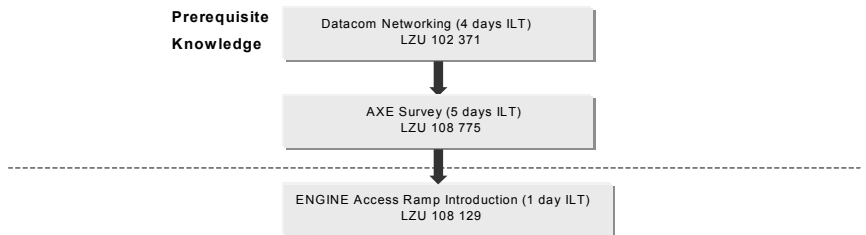

12 Business Management – ENGINE Multi Media

12.1 Executive Officers, Managers, Financial Mangers, Marketing, Sales, Business Managers & Team Leaders

12.1.1 Introduction to IP Networks, WBL (FAB 102 1313)

This is a complete Web Based Learning flow that provides a comprehensive introduction to the underlying principles of data communications. The flow is also integrated into the IP Fundamentals flow FAY 113 45 and contains information on;

How a PC communicates with other devices and networks, modern LAN and WAN technologies and concepts, the TCP/IP protocol suite, mobile network technologies, network

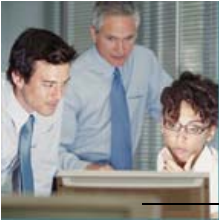

architecture and applications and the management of data networks.
This flow also serves to introduce topics that will be covered in more detail in further Ericsson courses.

12.1.1.1 Main Learning Objectives

1. Describe how to connect a PC to a datacom network
2. Explain the basics of networking, Local Area Networks (LAN) and the Ethernet Standard
3. Describe Wireless Local Area Networks (WLAN)
4. Describe the basic concepts of IP networking
5. Describe the basic concepts of IP internetworking
6. Describe how to use the network and describe IP network applications
7. Explain the TCP/IP data communications architecture
8. Understand fixed network connections: access networks
9. Understand the basic concepts of mobile access
10. Describe the technologies in the core network
11. Define core network architectures
12. Understand network operation and maintenance

12.1.1.2 Prerequisites

There are no prerequisites for this WBL flow.

12.1.1.3 Training Flow

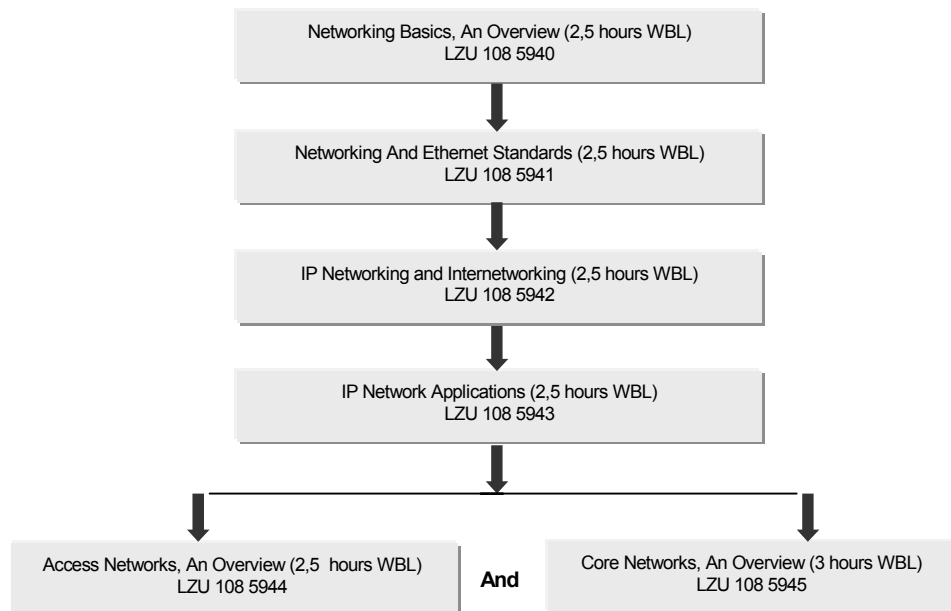

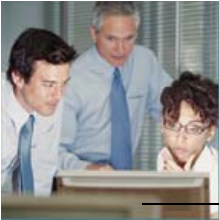

13 How Do We Deliver?

13.1 Process

All customer orders are placed with the Ericsson customer account team. The local Ericsson team is in turn supported by a training co-ordinator team and competence consultant your nearest Regional Training Center.

The co-ordinator team has close relations with all training units within Ericsson. Once the training schedule is agreed upon, the co-ordinator does the final bookings and produces a complete scheme for all training. When the courses start, the co-ordinator monitors the implementation and corrects and adapts changes that might be needed.

13.2 Delivery Methods

The content of our training package is delivered via web-based learning product or an instructor-led learning product, or a complete training flow consisting of several learning products, web-based and/or instructor-led.

The instructor-led courses can be delivered at Ericsson's regional or local training centers, or at your premises.

Ericsson Education Online provides you the access to web-based learning products, online articles, online booking to courses and support services through the Extranet or Internet portal.

13.3 Delivery Requirements

The training flows contain courses with practical exercises using Ericsson equipment. When these practical courses are delivered at the customer's premises, the customer must provide suitable training equipment for the course.

Using equipment in an operational network is generally not recommended, as Ericsson can take no liability for courses using live equipment.

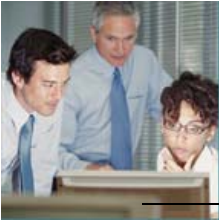

13.4 Trainer profiles

All Ericsson teachers are certified in the course(s) that they are conducting. The certification is carried out according to Ericsson's global certification process. The certification process involves pedagogical skills as well as technical skills related to the particular subject for the course.

13.5 Responsibilities

Training at Ericsson Training Centers:

The Ericsson Training Center is responsible for booking of classrooms and training equipment, course invitations, course certificates, etc.

Training at your premises:

The organising Ericsson training center shall explicitly define the requirements of classrooms, equipment, etc. to the customer.

Your training organization is responsible for course invitations, booking of classrooms, equipment, etc. according to the instructor's requirements.

14 Prerequisites

As a requirement, prerequisite knowledge varies from individual courses, please have a look at the course descriptions for more specific information.

15 Related Services

Knowledge Step

A learning campaign to increase knowledge for a large number of people in an effective way, in a short time period, with high quality. It is a managed customised solution that can be used to increase knowledge in different areas. The service targets entire organizations and is scalable from 500 to 10 000 participants. It is easily tailored to the needs of different customers and target groups. The service objective is to increase the knowledge in a specific area for an entire organization or part of an organization in a limited time frame.

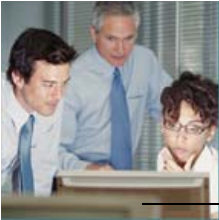

Competence Consulting

A service that evaluates the customer's competence and performance improvement needs, linking them to the customer's business goals. Using proven methods, Consultants assist executives, managers, and employees in the customer organization to achieve their full potential. The outcomes of this service include recommendations on complete and efficient solutions for competence development which are in alignment with business goals. The service can also provide the customer with job procedure definitions. The results of the service lead to higher performance levels and a more effective operational network and can also be used in such areas as career planning, recruitment and incentives planning.