

Ericsson Packet Backbone Network Solution Training Package



Marielle Lindgren

Product Manager, Education
Ericsson Global Services
marielle.lindgren@ericsson.com

Introduction

- This training package is supporting the Ericsson Packet Backbone Network Solution.
- The training package offers clearly defined yet flexible training paths to target specific technical and business staff within your organisation
- The training package uses blended learning – from traditional classroom teaching to learning off the web

Why invest in Ericsson Packet Backbone Network Solution Training Package?

- **Faster time to revenue**

“You can secure an rapid competence build-up, enabling an early Packet Backbone Network Solution launch.”

- **Cost efficiency**

“With competent and skilled staff, you will have a well-performed network, improving productivity and profitability.”

- **Increased performance/less churn**

“With competent and skilled staff, you will ensure high quality of service, leading to higher end-user satisfaction and competitiveness.”

- **Minimal risk**

“Your competent and skillful staff will be able to help you in maintaining a cost effective organization.”

- **Organizational effectiveness**

“Your staff will become more motivated through competence development and learning culture, which ensure you an effective organization for long-term success.”

What's in the Training Package? (Target Audience & Competence Levels)

Fundamentals

**Datacom
Fundamentals**

Field Maintenance

**Installation and
Maintenance**

Business Management

Business Management

Network Operation

**Network Surveillance
Network Configuration**

Customer Management

Customer Care

Packet Backbone Network - Fundamentals -

Introduction to IP Networks, WBL (FAB 102 1313)

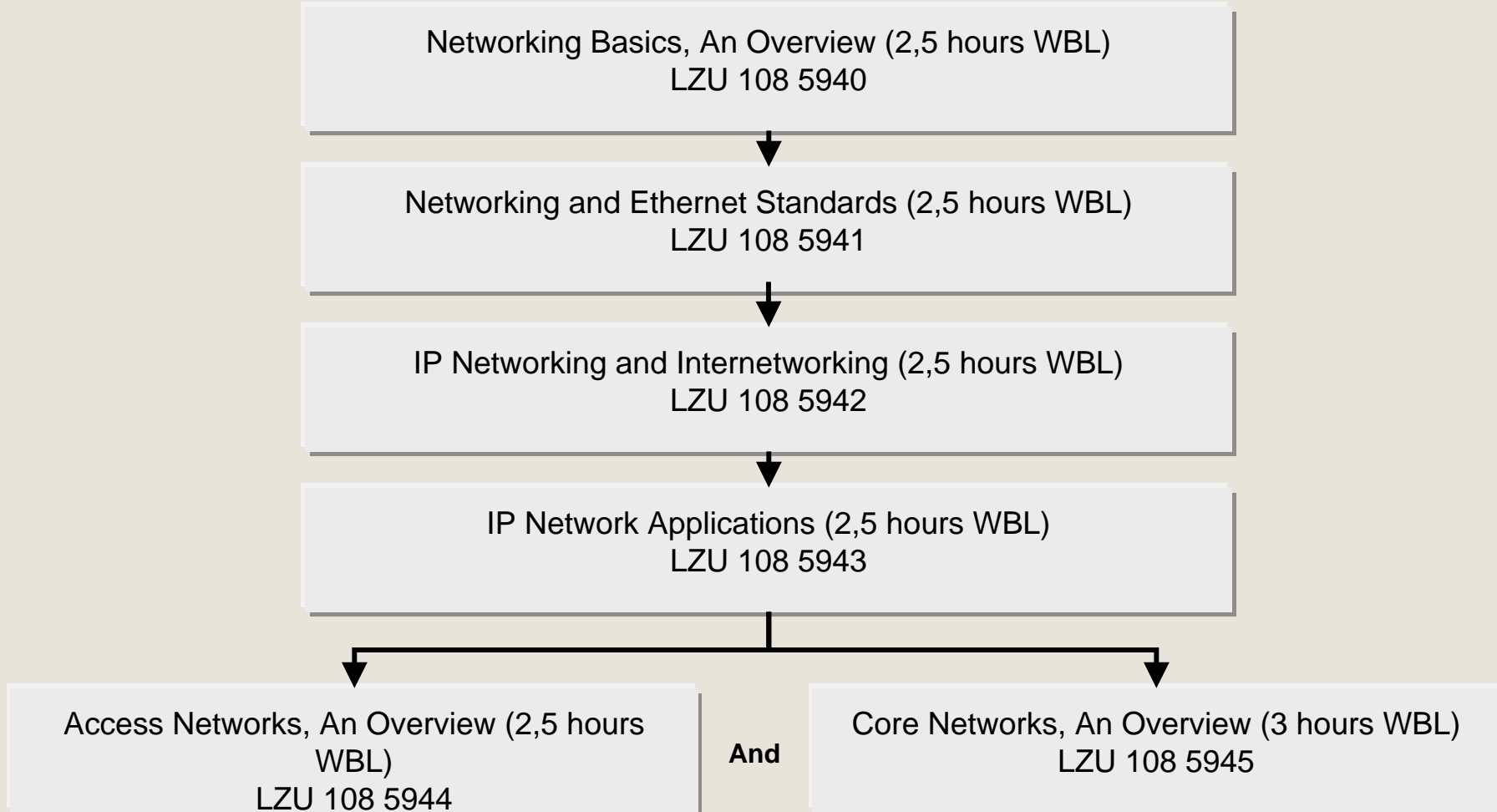

IP Fundamentals (FAB 102 1314)

Prerequisite Knowledge

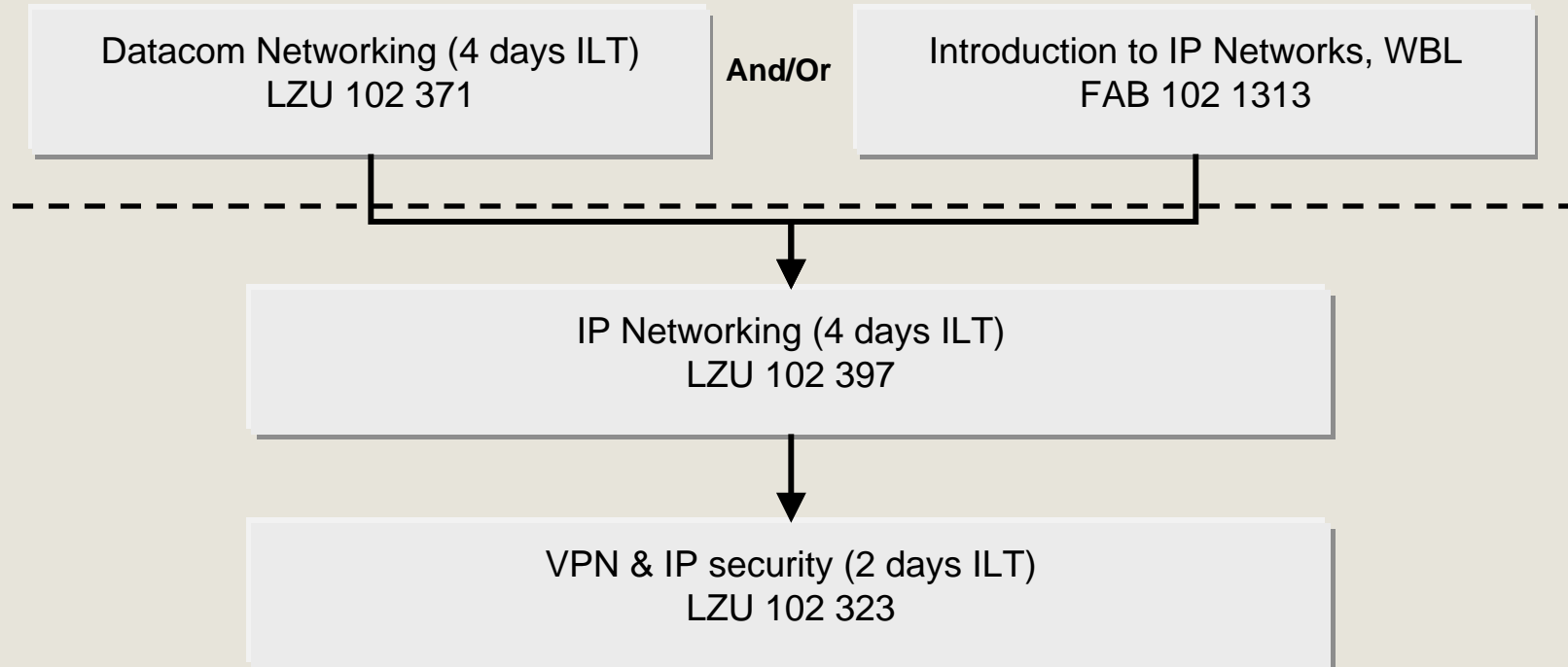

IPv6 Fundamentals (FAB 102 1383)

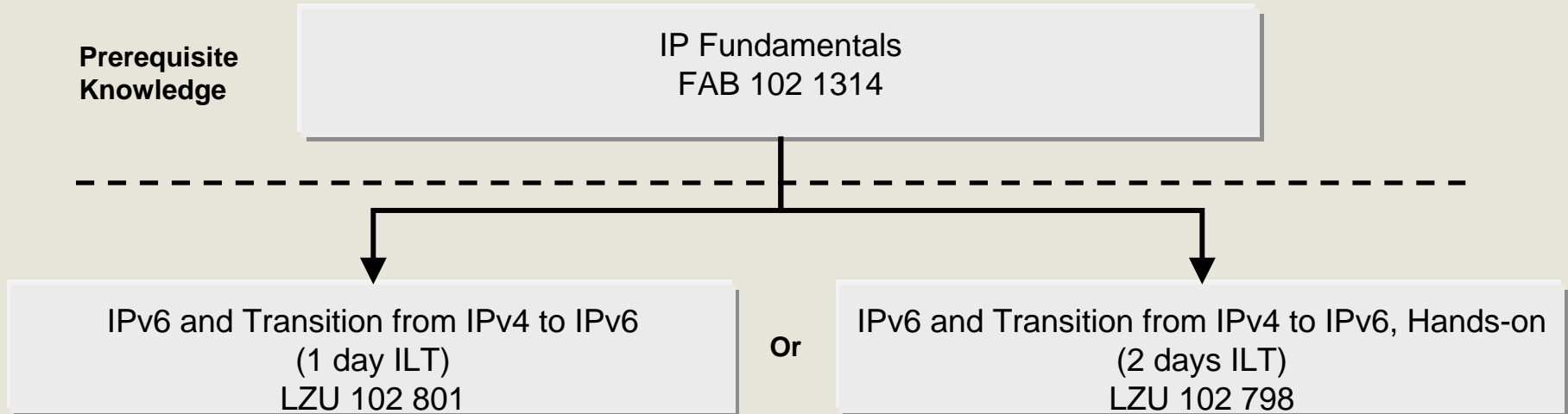

IPv6 Routing Configuration (FAB 102 1384)

**Prerequisite
Knowledge**

IPv6 Fundamentals
FAB 102 1383

IPv6 Routing Protocols (2 days ILT)
LZU 102 796

IPv6 Advanced Network Configuration (FAB 102 1385)

Prerequisite
Knowledge

IP Fundamentals
FAB 102 1314

IPv6 Advanced Features (4 days ILT)
LZU 102 797

ISP Network Surveillance (FAB 102 1368)

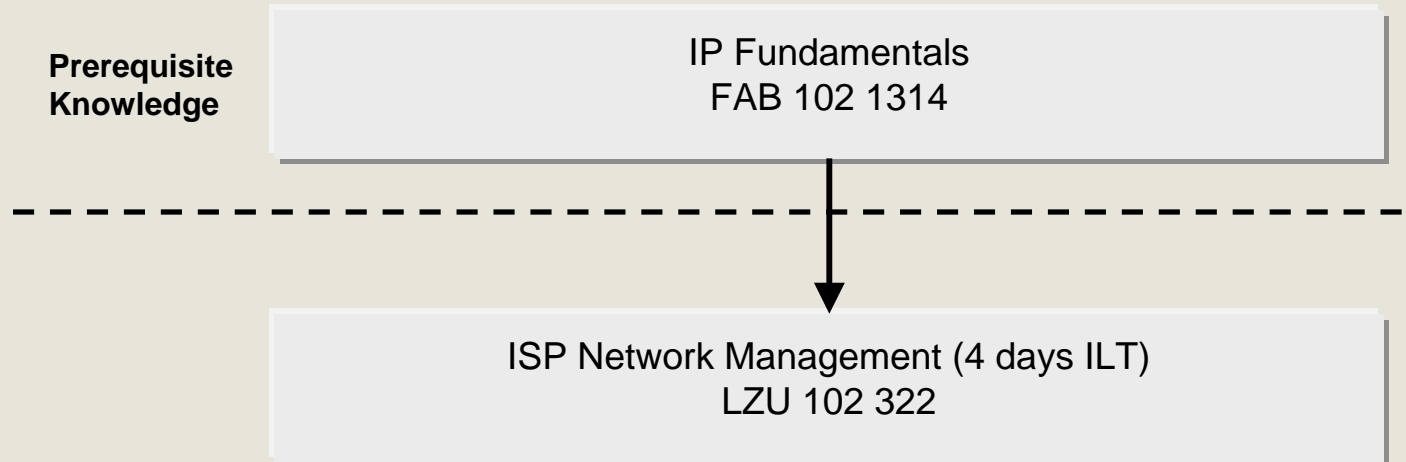

Packet Backbone Network Introduction (FAB 102 1373)

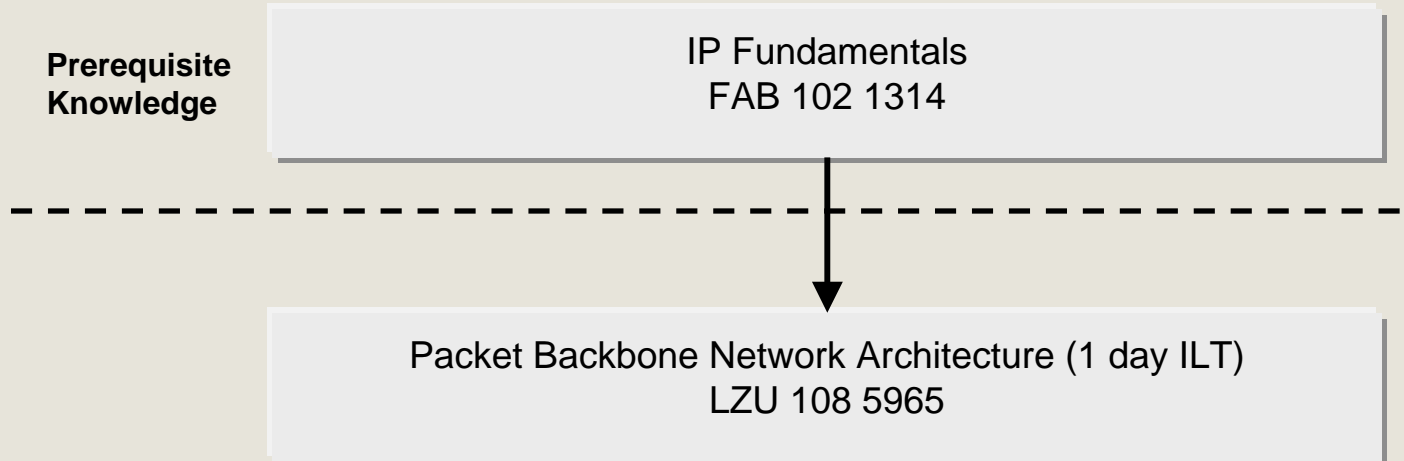

Packet Backbone Network - Field Maintenance -

PBN M&T-Series Router Installation (FAB 102 1369)

**Prerequisite
Knowledge**

Introduction to IP Networks
FAB 102 1313

PBN M&T-Series Router Installation and Maintenance (2 days ILT)
LZU 108 6069

Axerra AXN Installation (FAB 102 1370)

Axerra AXN Installation and Maintenance (1 day ILT)
LZU 108 6075

Packet Backbone Network - Network Operation and Configuration -

PBN IP Management Suite, Network Surveillance (FAB 102 1371)

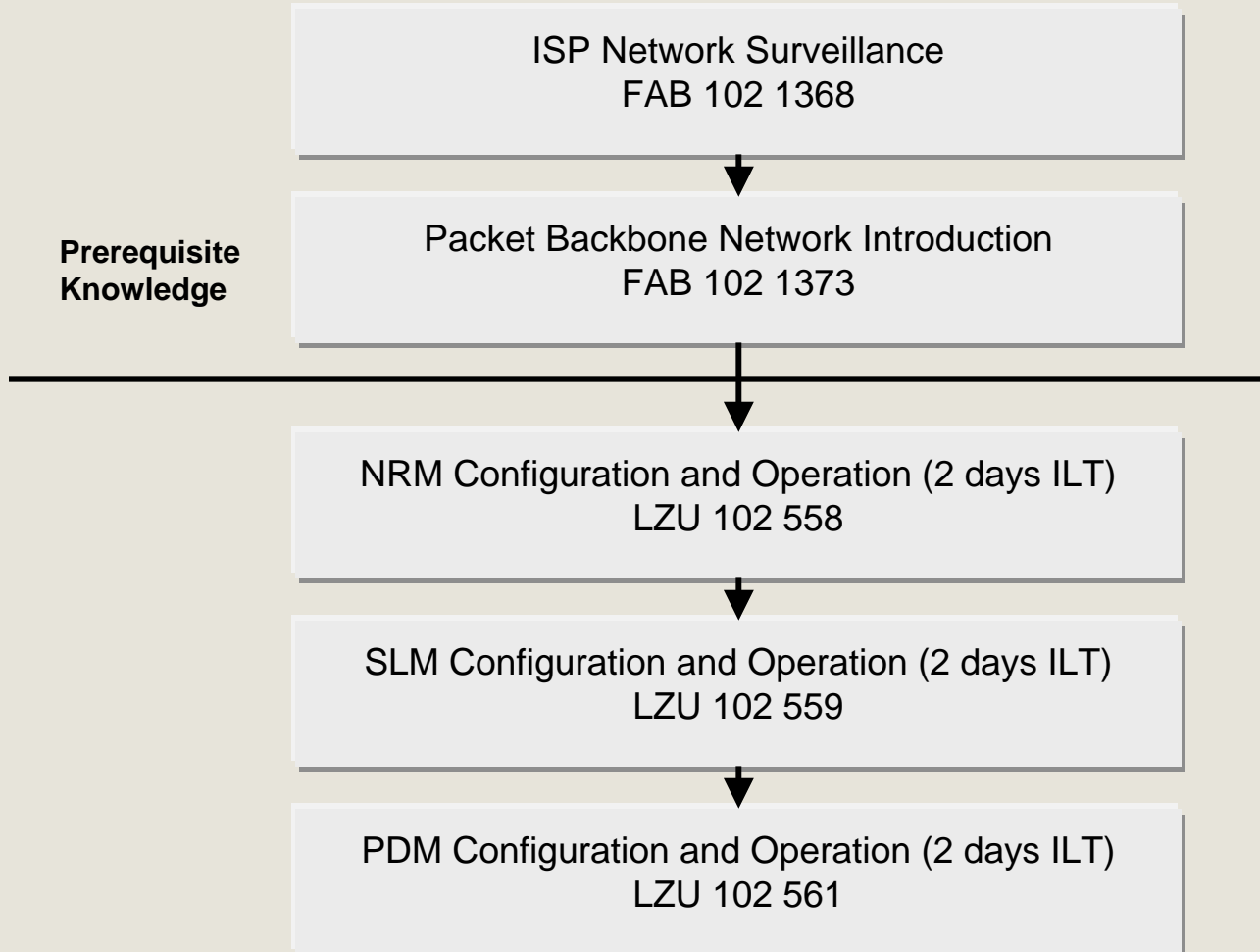

AXI 520/580 Network Configuration (FAB 102 1354)

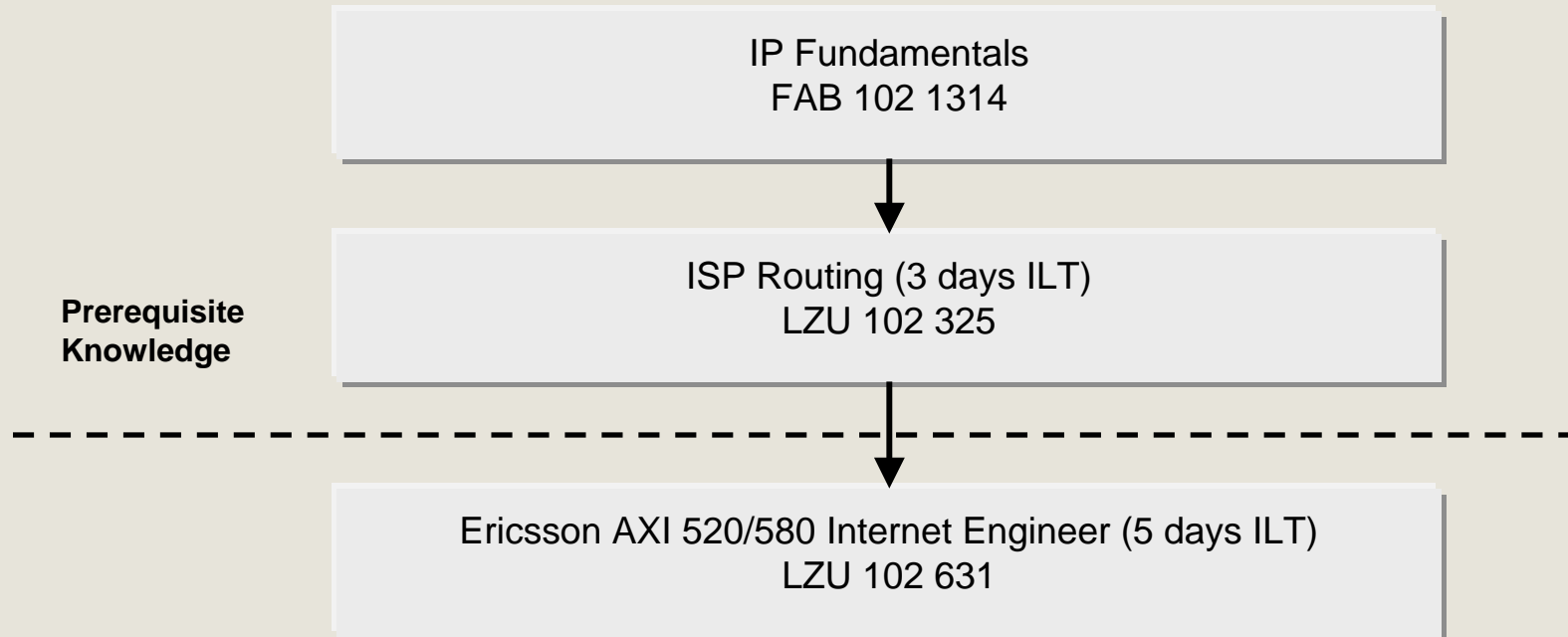

Axerra AXN Network Configuration (FAB 102 1372)

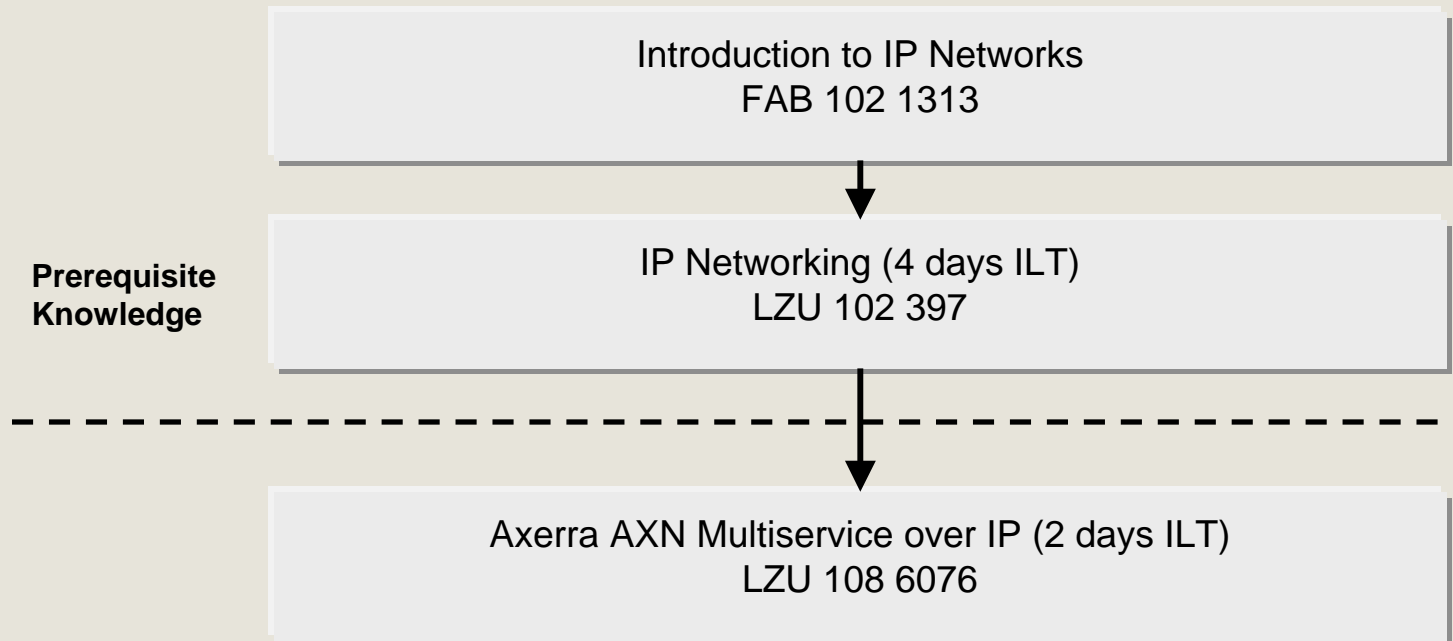

ERX Configuration (FAB 102 1405)

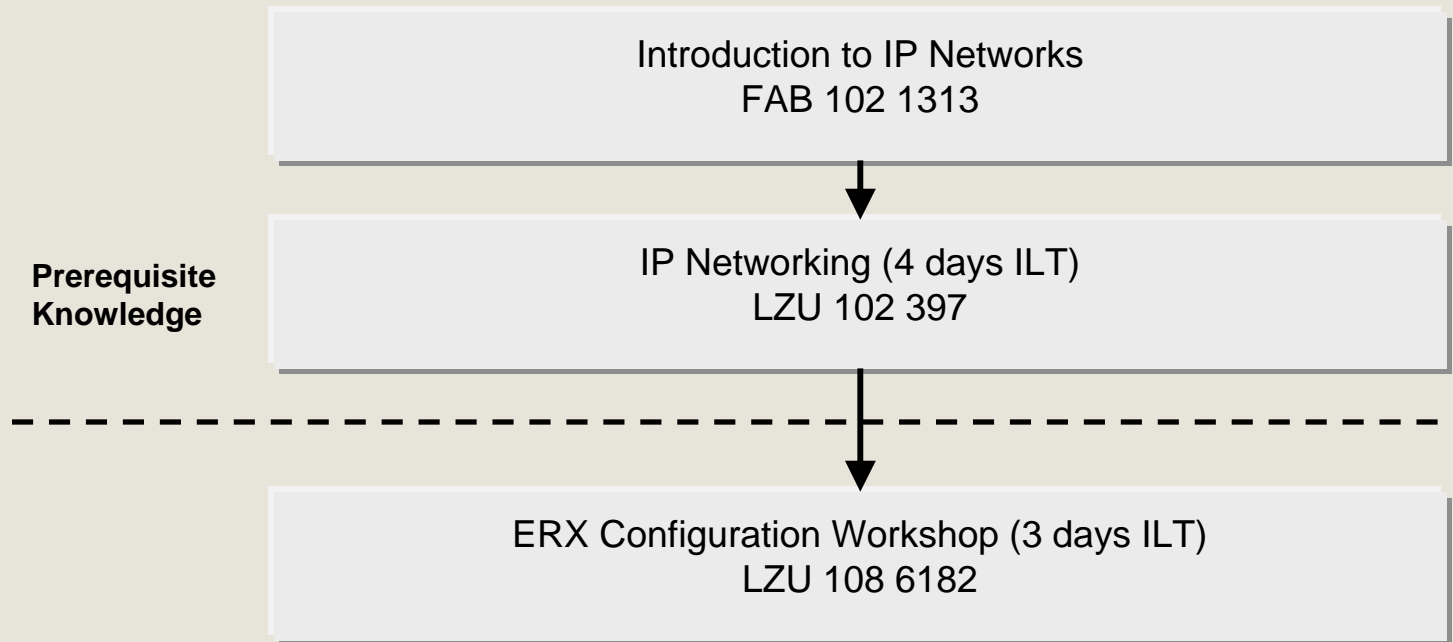

Packet Backbone Network Advanced VPNs (FAB 102 1374)

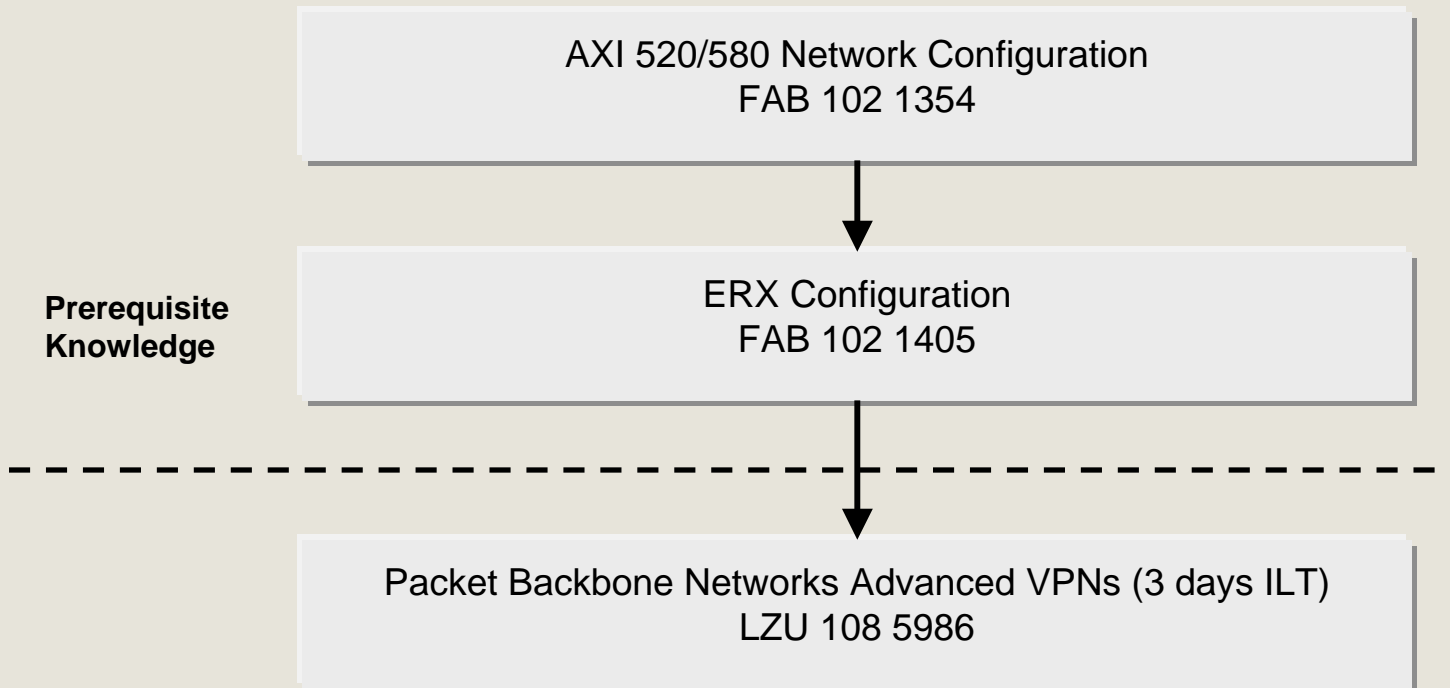

Packet Backbone Network - Business Management -

Datacom Fundamentals Business Management (FAB 102 1375)

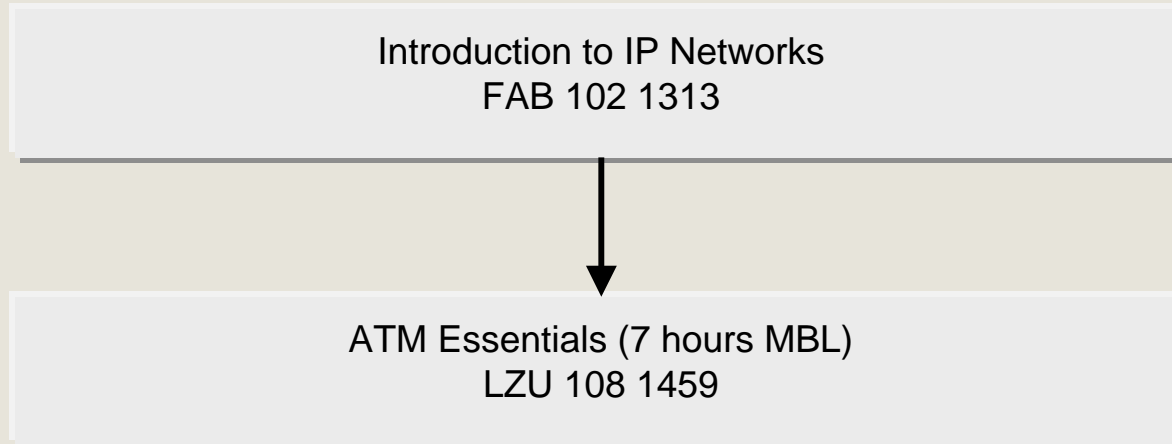

PBN Architectures - Business Management (FAB 102 1376)

**Prerequisite
Knowledge**

Datacom Fundamentals Business Management
FAB 102 1375

Packet Backbone Network Architectures (1 day ILT)
LZU 108 5965

Courses for Agents, Tele Sales and Help Desk personnel, and Team Leaders

**Customer Care Professionalism (2 days ILT)
LZU 108 3214**

**The Complete Team Leader Course (2 days ILT)
LZU 108 2049**

How do we deliver?

- ILT courses, delivered at Ericsson training centres or at customers site.
- e-learning products delivered by either Internet solution or Education Online portal on the extranet towards external customers.



Why Ericsson Education?

Global strength local expertise

- One of the worlds largest competet solutions suppliers

Broad Global Service Product Portfoli

Blended learning solutions

- Instructor Led Training (ILT)
- On-the-job programs
- Web based learning (WBL)
- Streaming Videos (SV)
- Seminars
- Multi-media based learning (MBL)
- Virtual Classroom/ Remote Training
- Online Articles
- On the Job Training
- Workshop



Cover all competence areas

- Technical/Professional, Business and Human skills

Summary

Be empowered

Ericsson Education is your competence partner. Linking human performance to business outcomes will give you the power to succeed. Our solutions combine global strength with local expertise - increase your performance anytime, anywhere.

With us, you will be first choice.

