

# Premium FWA experiences enabled by 5G network evolution towards 6G

Fixed Wireless Access handbook 2026



# Network evolution steps driving 5G FWA growth

## Scale FWA connections to grow revenues

### FWA benefits from a multi-service network

The starting point is one network for eMBB, FWA and IoT for lowest Total Cost of Ownership (TCO). Mid-band TDD being deployed in densely populated areas. The early commercial 5G networks relied on the LTE infrastructure for radio access and core network, referred to as 5G non-Standalone (5G NSA), to accelerate rollout. To unlock the full capability, performance and efficiency of 5G, service providers introduce 5G Standalone (5G SA) with a cloud native dual-mode core and highly efficient 5G air interface. 5G Advanced is also available to further enhance performance and capabilities.

### Network expansion driven by FWA

With the tremendous success of 5G FWA, next step is network expansion to capture the continued FWA connection growth. Increasing the household coverage of mid-band TDD. Adding spectrum, such as more mid-band TDD and mmWave, or densifying with new sites. Leveraging new capacity solutions such as FDD Massive MIMO. Deploying a distributed and separated Packet Core to be able to scale the FWA capacity independently.

## Broader FWA service offerings to grow revenues

Monetizing 5G FWA services further through differentiated offerings, focusing on varied price and performance tiers.

### 5G FWA introduction

Speed based service offerings are widely available for 5G FWA, with service providers monetizing FWA as a fixed broadband alternative. High speed broadband services are enabled with mid-band TDD coverage. Rich service capabilities are unlocked with 5G Standalone and the service toolbox in RAN and core networks.

### Differentiated FWA

Leading service providers are introducing premium experience FWA subscriptions with consistent performance. The monetization of experienced-based services, with requirements on consistent throughput, reliability, and latency, is enabled with e2e slicing, differentiated connectivity and 5G Advanced. Location awareness is also being used to manage and monetize FWA subscriber locations.

## Expanded service differentiation

The breakthrough of high-performing and programmable network capabilities is unleashing a new era of business innovation. Many new types of services offerings and device types will be added. The transition to an intent-driven service aware RAN, with distributed automation for real-time optimization at scale, will enable simpler operations, scalable automation, and faster deployment of differentiated services, forming a key step toward autonomous networks.

## Increasing use of AI and automation across E2E network

AI-enabled automation is essential to fulfill business needs and reduce operating costs. The use of centralized and distributed automation capabilities will increase across the E2E network, to manage new demands and increasing complexity.

See more on Ericsson 5G Advanced at: → <https://www.ericsson.com/en/5g/5g-for-service-providers/5g-advanced>

See more on Ericsson differentiated connectivity at: → <https://www.ericsson.com/en/differentiated-connectivity>

See more on Ericsson AI RAN at: → <https://www.ericsson.com/en/ai/ran>

## Growth drivers

## Network evolution steps

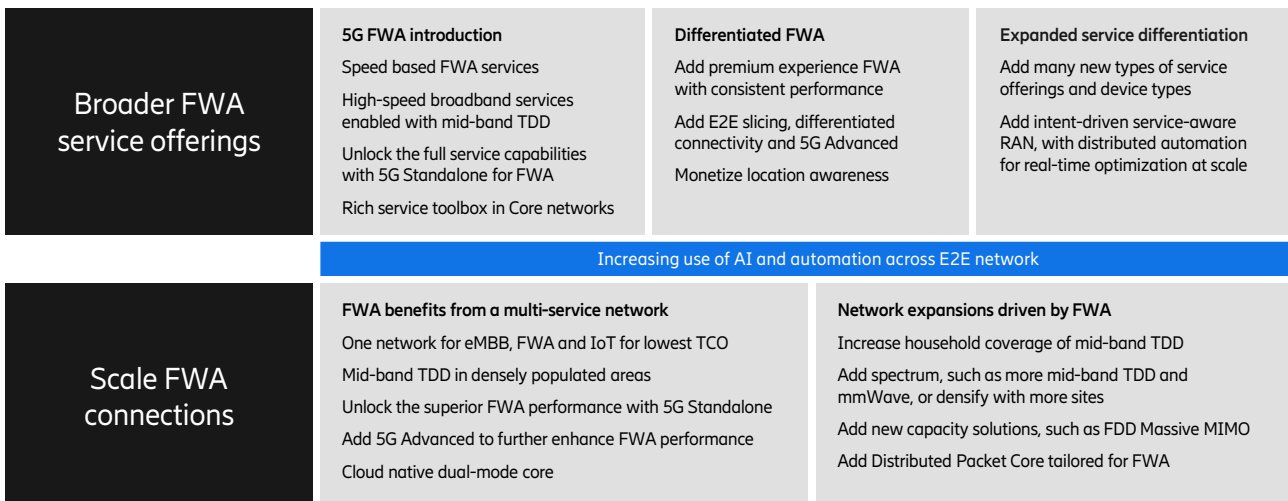

# Core Networks toolbox for FWA differentiation and monetization

Discover a versatile monetization toolbox to grow revenue streams in Fixed Wireless Access.

Key strategies for monetization include differentiated service tiers, premium performance for high value use cases, and location services for mobility monetization and network centric site control. For operators, this expands premium ARPU opportunities and retention by delivering a clear step up in QoE with predictable service tiers. At the same time, centralized provisioning and low signalling location control streamline operations and reduce OPEX, protecting margins across the lifecycle.

## Premium connectivity enabled by dual-mode 5G core

Dual-Mode 5G Core enables premium connectivity through advanced features that enhance network performance and user experience. Network-initiated Quality

of Service (QoS) supports static, dynamic, and API-based configurations, ensuring efficient traffic management and service differentiation. Advanced network slicing capabilities allow tailored connectivity solutions for diverse customer needs and industries. Additionally, Low Latency, Low Loss, Scalable throughput (L4S) deliver high-speed, reliable, and responsive connectivity, catering to performance-critical applications.

## Optimizing performance and user experience with Core Networks capabilities

Core network capabilities improve radio performance and user experience through more efficient traffic management with TCP optimization, adaptive bitrate, and radio friendly shaping. Content filtering, enrichment, and DNS caching further

enhance security, accelerate content delivery, and improve query resolution, boosting network efficiency and user satisfaction.

## Location awareness

Location awareness solves the challenge of FWA and MBB sharing the same network. Legacy network based site locking creates high signaling load, while device side locking is limited and adds operational complexity, customer care effort, and OPEX. By using location services CSPs can enable real time network centric site locking with minimal signaling, utilizing central provisioning and management of FWA subscriber allowed locations. The solution automates FWA site allowed/disallowed locations. Unlocking new monetization opportunities by safely enabling usage beyond the home.

Differentiation and monetization powered by rich service toolbox

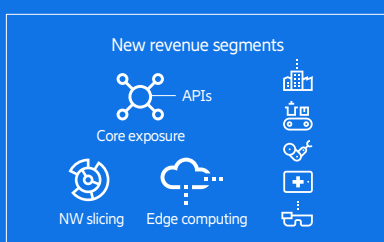

### Premium connectivity enabled by Dual-Mode 5G Core

- Network initiated Quality of Service (static, dynamic and API-based)
- Advanced network slicing capabilities (static and dynamic)
- Low Latency, Low Loss, Scalable throughput (L4S) Internet service

### Optimizing performance and user experience with Core Networks capabilities

- TCP Optimization, Adaptive bit-rate shaping, Large Flow Shaping, Radio Friendly Shaping
- Content filtering and enrichment, DNS caching and filtering

### Location awareness

- Mobility monetization – multi-location subscription, policy-based restrictions
- FWA Usage control – fair usage policy and QoE management, in line with regulation

# Core network evolution for FWA supported by distinct deployment paths

## Core networks capabilities

- Same core network functions for eMBB, FWA and IoT traffic
- Built versatile to run in centralized, distributed, Edge and Cloud scenarios
- Gi-LAN services and advanced security
- Energy efficiency and automation

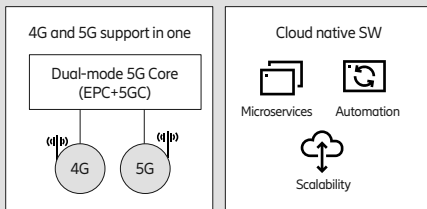

## Deployment options

### One network optimized for TCO and performance

CAPEX and OPEX optimization enabled by co-deployment and dynamic resource allocation.

High FWA performance while serving other use cases i.e. MBB and IoT.

Protection of MBB traffic done with policies to ensure high service quality for key users.

### Distributed packet core for FWA

FWA traffic growing faster than MBB traffic, scale independently.

Tailored system performance by separating FWA traffic and easy scaling based on FWA traffic model.

Simpler operations, allowing different life cycle management of FWA instances.

The Core Network for Fixed Wireless Access is built on a cloud native architecture that enables agility and efficient lifecycle management. Dual Mode 5G Core provides a solid foundation to deploy and operate FWA services cost effectively while creating room for innovative, revenue generating offerings. Cloud native components deliver scalability and flexibility across centralized, distributed, edge, and cloud environments, reducing OPEX through in service software upgrades (ISSU) and container as a service (CaaS) rolling upgrades. An optimized data plane payload processing design sustains very high throughput with energy efficient operation on standard hardware, allowing service providers to manage resources effectively and support FWA traffic growth. The solution maintains consistent traffic analytics and insights after subscribers connect, with provider controlled enablement of Deep Packet Inspection (DPI), Event Based Monitoring (EBM), software probes, and more, adjustable to the desired granularity and investment per segment. It also ensures continuity of Gi LAN services such as Network Address Translation (NAT), firewall with regulatory

logging, content filtering (for example, Internet Watch Foundation compliance), and large flow shaping. This consistency across deployments is critical to delivering reliable, secure connectivity while keeping operational costs in check.

## One core network with unified cloud-native software and infrastructure

Utilizing a versatile user plane deployment framework designed to seamlessly serve multiple segments—Mobile Broadband (MBB), Fixed Wireless Access (FWA), and Enterprise—as required by demand. Fully utilizing the cloud-native infrastructure to avoid the creation of hardware and software silos, fostering operational efficiency. Deploying unified user plane software that ensures compliance with 3GPP standards and includes cloud-native capabilities. This approach minimizes the complexity of managing multiple deployments and can simplify lifecycle management.

## Benefits of a distributed packet core deployment for FWA

As FWA capacity demands grow, central sites can become overly burdened and reach optimal scale. Having a distributed and separated Packet Core deployment, with UPF only or a combined UPF and SMF deployment, allows service providers to scale the FWA capacity independently. The distribution enables optimization of the system performance as it will be designed specifically for FWA traffic. The traffic models can remain simpler compared to the variability required in MBB, enabling higher throughput per server and increased resource utilization for specific purposes. FWA and MBB may have differing requirements for software updates and upgrades. A separate distributed architecture makes it easier to align lifecycle management processes with the unique demands of each service, ensuring flexibility and operational efficiency.

# Bharti Airtel distributed packet core deployment for FWA

Evolving from initial enabled FWA on existing Core Network (combining FWA and MBB on same instances) to a separated and distributed Packet Core deployment. An evolution driven by rapid growth in FWA traffic and the need for independent growth of FWA capacity by adding Packet Core instances.

Bharti Airtel's Fixed Wireless Access expansion, driven by its collaboration with Ericsson, addresses the need for scalable broadband solutions amidst soaring demand, with connections growing from 750 thousand in 4Q24 to 3.1 million by 4Q25. The deployment features Ericsson's Local Packet Gateway (LPG) as the FWA User Plane Function, enabling efficient load-sharing, enhanced scalability, and

high-performance connectivity using both Outdoor and Indoor CPE. Building on their dual-mode 5G Core, the initiative supports Airtel's transition to 5G Standalone (SA) with improved cost efficiency and optimized infrastructure. Designed to meet fast-evolving customer data demands, this collaboration fosters digital inclusion and bridges the connectivity divide for diverse geographic regions.

Bharti Airtel needed to transform their current deployment to enable independent capacity growth of FWA. By strategically placing a distributed, dedicated and high performing UPF for FWA allowing them to scale the FWA capacity independently, not affecting MBB traffic. The new deployment is aimed to deliver fiber-like FWA experience.

Bharti choose to deploy the Local Packet Gateway providing high efficiency, flexible scaling, and reliability. The deployment ensures load sharing across LPG instances to ensure smooth traffic distribution and resilience and allow one-to-many use of outdoor and indoor CPEs for cost-effective, high-performance connectivity across diverse regions.

→ <https://www.ericsson.com/en/press-releases/2/2025/7/bharti-airtel-chooses-ericsson-core-for-fixed-wireless-access>

## Challenges

- Evolve current FWA deployment due to high increase in FWA subscribers and capacity
- Independent capacity growth of FWA traffic with low TCO, separated from MBB

## Strategic intent

- Enabling independent scaling of packet core for growing 5GSA FWA traffic
- Fast time-to market for new FWA platform to cater for rapid traffic growth
- Enabling access via Multi-Dwelling unit (MDU) CPE to condominiums.

## New solution

- Dedicated, distributed high-capacity user plane deploying Ericsson Local Packet Gateway (LPG)
- Integrate LPG with eMBB Ericsson Packet Core Controller (PCC) for centralized control and policy enforcement
- Enable horizontal scale and resiliency through load sharing across multiple LPG instances.



# The RAN toolbox for 5G FWA

FWA is established as a very successful primary service of 5G, with many enhancements to address its unique characteristics.

The superior network performance of 5G is the foundation for the success of FWA and the opportunity to provide fiber-like services on a large scale.

5G Standalone (SA) unlocks the full potential of 5G. The software upgrade to 5G NR Standalone provides enhanced user experience, increased coverage, improved network efficiency, less complexity and enables new business opportunities.

Carrier aggregation (CA) is essential to deploy better 5G. It maximizes the use of scattered spectrum and enhances the user experience. It is also a powerful tool to extend the coverage.

Massive MIMO (M-MIMO) is a key component to accelerate 5G. The solutions for beamforming, single-user and multi-user MIMO enhance the user experience, capacity, and coverage of the radio access network.

New and more spectrum is becoming available in mid-band TDD and mmWave, with wide bandwidths that can carry large amounts of data traffic.

Slicing and differentiated connectivity is enabling the opportunity to generate more revenues, with experience-based services, with high requirements on consistent throughput, reliability, and latency. As for example premium FWA.

RAN Differentiated connectivity is key enabler for the 5G monetization opportunities. This software solution offers service differentiation and guaranteed performance for many new services, with an overall efficient utilization of the common 5G RAN. It supports dynamically optimization of radio resource allocation and prioritization across different slices, for guaranteed service-level agreements fulfillment.

Many RAN features are service-aware for the differentiation of services, functions, and feature behavior in terms of configuration and observability. Adapting the RAN behavior to fulfil diverse services and requirements. It can, for example, be used to optimize parameter settings for best FWA performance, steer FWA subscribers to a certain frequency band, as well as provide observability for the FWA UE group.

AI-enabled automation is essential to fulfill business needs and reduce operating costs. An intent-driven service-aware RAN, with distributed automation for real-time optimization at scale, enables simpler operations and faster deployment of differentiated services.

A characteristic of FWA is using high-performance devices in fixed locations, with typically good RF conditions and high data consumption. Specific enhancements can be applied for optimization in these unique scenarios. Example areas of FWA

enhancements are coverage, speed, and capacity.

For example, FWA users can benefit from much higher upload speeds and capacity with the combined use of uplink single user MIMO and uplink carrier aggregation. This requires devices with three transmit antennas (3Tx), which is especially appealing for FWA service providers given that device output power constraints and the placement of additional radio frequency components is simplified for FWA devices with larger form factor in contrast to smartphones.

→ <https://www.ericsson.com/en/news/2023/7/ericsson-mediatek-reach-new-tech-milestone-for-fwa-market>

Another example is FWA deployments with good line-of-sight propagation conditions, between high tower radio sites and outdoor roof-top mounted CPEs, can deliver much longer mmWave cell ranges – up to 14 kilometers – in contrast to smartphones. This requires the use of high-power radios, high-power CPEs, and a mmWave extended range software that can accommodate the increased propagation time at longer distances.

→ <https://www.ericsson.com/en/press-releases/2/2025/3/ericsson-nbn-co-and-qualcomm-achieve-5g-mmwave-breakthrough-extending-range-to-14-km-with-gigabit-speeds>

FWA is established as a very successful primary service of 5G, with many enhancements to address its unique characteristics.

## Optimization – FWA enhancement examples

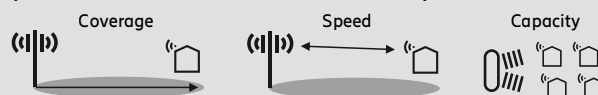

For high performance FWA devices, in fixed locations, with high data consumption.

## Generate more revenue – RAN Differentiated Connectivity

Network Slicing



Adapt the RAN behavior to fulfil diverse services and requirements.

## Foundation – Superior network performance

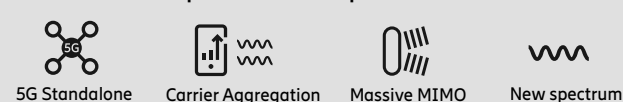

Exceptional user experience and network capacity.

# Multiple FWA benefits enabled by 5G SA

In the context of Fixed Wireless Access, the introduction of 5G Standalone marks a significant event, enhancing efficiency, performance, and differentiation for FWA.

The freedom from 4G infrastructure empowers service providers to shape 5G networks, unlocking the full potential of spectrum resources. This strategic autonomy, coupled with immediate NR access and reduced latency, results in a streamlined FWA ecosystem. It signifies a fundamental shift towards efficiency, where the reduced \$/GB for 5G FWA becomes a reality, underscoring the financial soundness of 5G SA.

Performance is a key focus as 5G SA maximizes NR spectrum utilization. With instant access, it simplifies the Radio Access Network and CPE devices drastically. Unlike 5G NSA, SA operates without an LTE anchor, resulting in ultra-

fast connections and enhancing the end-user experience. The SA approach, avoiding power-sharing with LTE, allows full power utilization for NR, resulting in superior uplink coverage and throughput. Together with superior Massive MIMO performance, these enhancements have a strong positive impact on throughput, contributing to an overall improvement in network capacity available for FWA.

5G SA empowers service providers to stand out in a competitive landscape, enabling them to differentiate their FWA offerings. By leveraging 5G SA's capabilities, service providers implement sophisticated monetization strategies, taking advantage of network

slicing and speed differentiation.

This not only optimizes FWA revenue but also establishes a framework for offering tailored services with specific commitments. Whether serving residential users, businesses, or online gaming, service providers can customize FWA services for optimal performance, enhancing the overall customer experience.

In summary, 5G SA transforms the FWA scenario with its emphasis on efficiency, performance, and differentiation. By maximizing spectrum use, optimizing service performance, and providing unique services, 5G SA becomes a strategic enabler for service providers to develop new revenue streams for premium FWA connectivity.

## Offload 4G to 5G FWA



Lower \$/GB for 5G FWA  
Easy to migrate (data-only, stationary)

### Efficiency

## Coverage extension

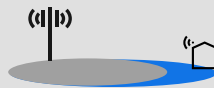

FDD and TDD CA increases mid-band coverage and system capacity

### Performance

## Slicing



Monetize with SLAs for FWA  
Tailored offerings for new business

### Differentiation

## Spectrum management



Maximize utilization of NR spectrum  
Instant access to NR and lower latency

## Speed and Capacity



Capacity and speeds enhancements  
Optimized for service performance

## Intelligent traffic management



Differentiated mobility and CA behavior for different user groups

# Premium FWA services enabled with RAN Differentiated Connectivity

## Differentiated connectivity toolbox with 5G advanced

- **Prioritized RAN Scheduling** – such as Relative Priority Scheduling (RPS) and Rate-Controlled Scheduling (RCS)
- **Radio Resource Partitioning (RRP)**
- **Service-specific observability**
- **Automation** – distributed real-time and centralized non-real time

## Differentiated connectivity

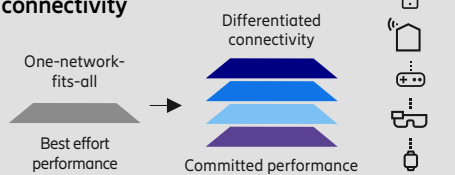

## Automation example

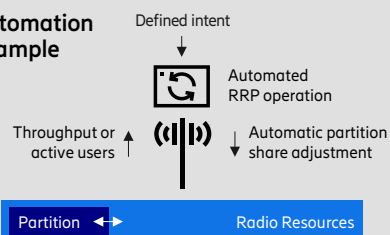

## Premium FWA examples

### Relative Priority Scheduling (RPS)



### Rate-Controlled Scheduling (RCS)



### Radio Resource Partitioning (RRP)



Simplified illustrations - numerous scheduling functions used in a multi-service RAN

RAN Differentiated Connectivity is key enabler for the 5G monetization opportunities. It brings the ability to shift from a best-effort network to one that enables committed performance for many services with different performance needs. It will be more about ensuring consistent quality and user experience, targeted to specific needs on consistent throughput, reliability, and latency, rather than promoting peak speed. As for example for Premium FWA services with minimum guaranteed performance, especially during the peak evening hours.

**The RAN differentiated connectivity toolbox** provides an efficient allocation of finite radio resources based on service provider defined end user target such as relative priority, throughput, or latency. Flexible and automated Radio Resource Management functions fulfil varying service requirements and achieve best performance. The business objectives, targeted services and use of these tools can vary between different Communication Service Providers (CSPs). It is essential for CSPs to have a strategy including spare radio resources for future premium services.

Relative Priority Scheduling provides relative priority differentiation between users and services. Relative priority differentiation has the advantage of a low risk for starvation of users with lower relative priority. A typical use case is differentiated subscriptions where a "Gold-subscriber" has a higher relative priority than a "Silver-subscriber".

Rate-Controlled Scheduling (RCS) provides service differentiation with respect to provided throughput of QoS flow. For example, to provide a prioritized minimum throughput for a premium service.

Radio Resource Partitioning (RRP) provides dynamic resource sharing between Resource Partitions with resource guarantees during times of contention, protecting services and SLA fulfilment.

Service-aware RAN enables rapid scaling of new use cases and customer needs, by being able to adapt to the connectivity requirements of different services and ensuring that RAN can adjust in real-time to fulfil service requirements and provide service-specific observability to support proof of delivery for each

service. The service-aware RAN can also, for example, be used to optimize parameter settings for best FWA performance, steer FWA subscribers to a certain frequency band, as well as provide observability for the FWA UE group.

Communication service providers need to efficiently utilize limited resources in complex environments to deliver the superior network performance, customer experience, and operational excellence expected of them. An intent-driven service-aware RAN, with distributed automation for real-time optimization at scale, enables simpler operations and faster deployment of differentiated services.

One example is the automation with RRP, an intent-based automation tool to provide just fit radio resources to a partition using throughput or active user KPI as intent. It automatically adjusts the resource share for improved overall end-user experience, and enhanced network experience.

See also:  
→ <https://www.ericsson.com/en/differentiated-connectivity>

# Superior Massive MIMO performance with optimizations for FWA

The 5G future is here with more deployments, ever-increasing data traffic and subscriber growth. Massive MIMO is a key component to accelerate 5G with new levels of spectral efficiency and flexibility, to meet the new performance demands. The software solutions for beamforming, single-user (SU) and multi-user (MU) MIMO enhance the user experience, capacity, and coverage of the radio access network.

Downlink capacity is often the limiting factor in FWA dimensioning due to that the traffic is dominated by video related content in the downlink. Consequently, any capacity improving feature is important for FWA. The FWA networks are therefore a sweet spot for Massive MIMO solutions and deployed capacity enhancement investments can quickly be rewarded by larger revenues.

In MU-MIMO operation, the system can transmit several layers – not just to one device, but to multiple devices simultaneously. FWA is an example where MU-MIMO is very beneficial since the devices are stationary and the traffic is heavy and dominated by data in longer sessions with relatively large packet sizes. This means that spatially well-separated users can be scheduled simultaneously without causing too much inter-device interference.

An overall efficient use of the total MU-MIMO capacity is important, as there are many different types of devices and services in the network. Regular beamforming is codebook based, while advanced beamforming is reciprocity-based and uses the SRS transmitted by the UEs. Reciprocity-based beamforming can provide improved downlink multi-user MIMO performance, increased spectral efficiency, and increased downlink cell throughput - if the radio conditions, the amount of data and the location of the UEs are favorable.

## Examples of Massive MIMO performance optimizations are:

- **Buffer-based beamforming** mode adaptation, which select the optimal beamforming mode so that heavy traffic users, such as FWA, are prioritized for the use of reciprocity-based beamforming.
- 5G Advanced also brings **Service specific Massive MIMO** which improves SU- and MU-MIMO performance and overall network capacity and spectral efficiency by optimizing Massive MIMO parameters for different types of services and device, such as FWA.
- **AI native RAN** represents a major leap forward, embedding intelligence directly into the RAN to enable real-time, intent-driven optimization. AI predicts traffic patterns to improve traffic steering, to optimize spectrum efficiency and increase user throughput and reduce energy consumption. AI native Link Adaptation is one example of AI in RAN. It enables optimised spectrum usage and downlink performance through real-time reinforcement learning.  
→ <https://www.ericsson.com/en/press-releases/6/2025/ericsson-and-bell-canada-successfully-test-ai-native-link-adaptation-to-boost-network-speed-and-efficiency>

Massive MIMO is also of high value for Uplink performance. When the coverage is good, UL multi-user MIMO (MU MIMO) – which serves multiple users with the same radio resources – will improve UL capacity.

See also Ericsson Massive MIMO:

→ <https://www.ericsson.com/en/ran/massive-mimo>

See also Ericsson AI RAN:

→ <https://www.ericsson.com/en/ai/ran>

### Buffer-based beamforming mode adaptation

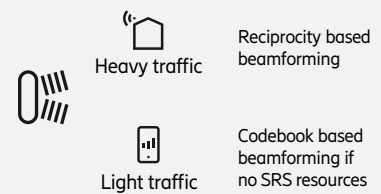

### Service Specific Massive MIMO

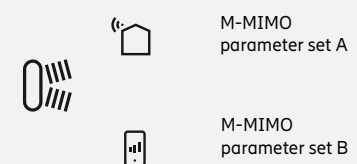

### AI in RAN

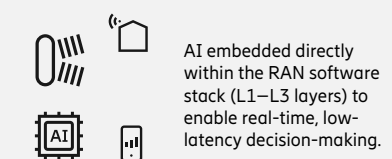

# Uplink performance enhancements for FWA

## Carrier Aggregation

5G Carrier aggregation (CA) is essential to deploy better 5G. It maximizes the use of scattered spectrum and enhances the user experience. It is also a powerful tool to extend the coverage. The full 5G CA capabilities are enabled by 5G Standalone (SA).

For FWA the focus is on aggregation of the capacity bands, such as mid-band TDD, but also an FDD band could be included to enhance UL coverage and speed.

For downlink (DL), CA of 2-3 component carriers (CC) and with up to 4-layer single user (SU) MIMO is typically used. The carrier aggregation capabilities are continuously stretched and support for up to 6CC DL CA is now emerging, enabling

up to 3.5x higher DL throughput compared with 1CC TDD 100MHz.

→ <https://www.ericsson.com/en/news/2023/8/ericsson-ups-the-tempo-on-5g-carrier-aggregation-with-worlds-first-downlink-6cc-data-call>

See more on Ericsson Carrier Aggregation at:  
→ <https://www.ericsson.com/en/ran/carrier-aggregation>

## Uplink performance enhancements for FWA

The uplink (UL) is also essential and is getting more attention with emerging applications requiring high uplink performance. Examples of such new services include GenAI

(generative artificial intelligence) apps, conversational video/video conferencing, live broadcasting and augmented/mixed/virtual-reality use cases.

→ <https://www.ericsson.com/en/reports-and-papers/ericsson-technology-review/articles/achieving-networks-with-high-performing-uplinks>

Some of the device dependent UL performance enhancements are especially appealing for FWA service providers given that device output power constraints and the placement of additional radio frequency components is simplified for FWA CPE devices with larger form factor, in contrast to smartphones.



### 5G NR Uplink toolbox

- UL Single-User (SU) MIMO
- UL Carrier Aggregation (CA)
- UL Transmit (Tx) switching
- Higher UE Power Class (PC)
- UL Multi-User (MU) MIMO



### Supports high UL usage today and in the future

- FWA for Enterprise
- UL capacity/coverage constraints (e.g., Indoor CPE)
- FWA for XR gaming
- AI-driven use cases

### Examples

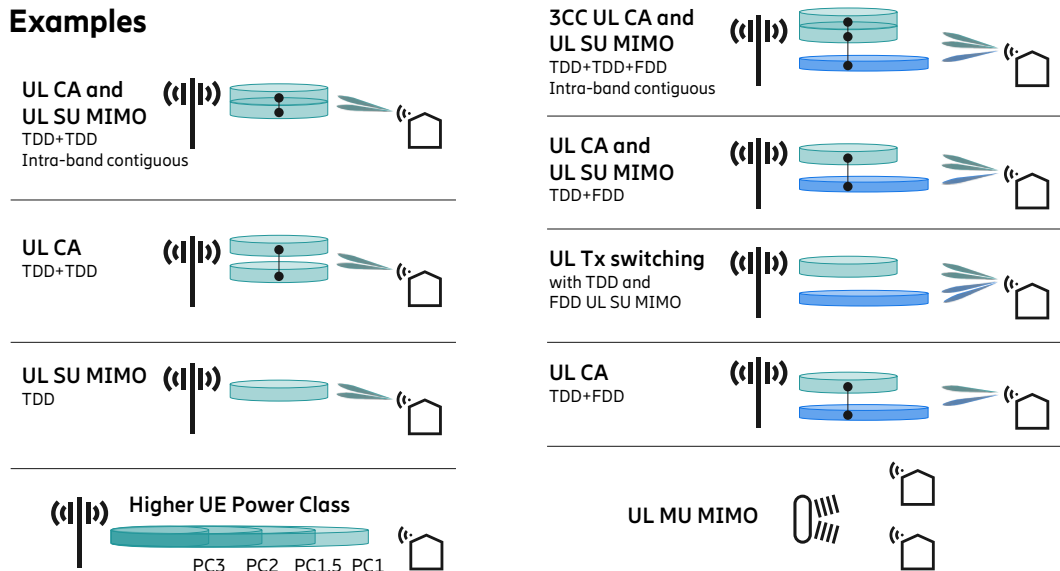

Today higher UE transmit power is common for FWA with the high Power Classes PC2 (26dBm), PC1.5 (29dBm) and the emerging PC1 (31 dBm), enhancing the uplink coverage and capacity as compared to the regular PC3 (23dBm).

UL SU MIMO sends data using two signal streams in the UL. It is supported for both TDD and FDD bands and can double throughput when the device is in good UL coverage.

UL CA uses more than one frequency carrier in the UL. By combining multiple frequency bands, it improves the user experience for devices that are in the overlapping coverage of these bands. It is supported for aggregating TDD+TDD, TDD+FDD and FDD+FDD bands.

'UL Tx switching' switches UL transmissions between TDD and FDD bands. This enables a device with two transmit antennas (2Tx) to transmit two layers in the UL on TDD during the TDD UL slot, then dynamically switch the Tx chain to FDD during the TDD DL slot to provide high throughput.

FWA users can benefit from higher upload speeds and capacity with UL CA (TDD+FDD) in combination with UL SU MIMO (TDD), with up to 3 layers. This requires devices with three transmit antennas (3Tx), which is especially appealing for FWA CPE devices.

→ <https://www.ericsson.com/en/news/2023/7/ericsson-mediatek-reach-new-tech-milestone-for-fwa-market>

UL enhancements are also emerging with support for even more layers. One example is UL CA for intra-band contiguous TDD+TDD in combination with UL SU MIMO, with up to 4 layers.

→ <https://www.ericsson.com/en/press-releases/6/2025/verizon-ericsson-qualcomm>

Another emerging example is 3CC UL CA, for 1CC FDD and 2CC intra-band contiguous TDD, in combination with UL SU MIMO for TDD, with up to 5 layers. This requires devices with three transmit antennas (3Tx).

Massive MIMO is also of high value for Uplink performance. When the coverage is good, UL multi-user MIMO (MU MIMO)

– which serves multiple users with the same radio resources – will improve UL capacity.

The comprehensive 5G NR Uplink toolbox supports high UL usage today and in the future for FWA cases such as: FWA for Enterprises; UL capacity/coverage constraints (e.g. Indoor CPEs); FWA for XR gaming; AI-driven use cases.

## mmWave

Carrier aggregation is also used for the very wide mmWave (FR2) spectrum with typically 4-8CC CA for DL and 2-4CC CA for UL. With the use of NR-DC (Dual Connectivity) one can combine sub-6GHz FR1 (CA) with FR2 (CA) to get peak speeds of about 10Gbps and beyond in DL and more than 2.2 Gbps in UL.

→ <https://www.ericsson.com/en/press-releases/7/2025/ericsson-telstra-and-mediatek-achieve-major-breakthrough-with-near-10-gbps-5g-downlink-speed-benchmark>

→ <https://www.t-mobile.com/news/network/t-mobile-shatters-for-5g-uplink-speed>

# Next wave of premium FWA – add mmWave

## A profitable use of mmWave spectrum

- Offer wireless fiber services
- Connect more households
- Support higher data consumption
- Benefit from combined mmWave + mid-band FWA

## Superior peak speeds

- Downlink up to 10 Gbps
- Uplink up to >2 Gbps

## Add mmWave

- Typical 400-800 MHz of additional spectrum
- Enable ~3x capacity with gigabit speeds

## Global focus



All service providers with mmWave spectrum explore the use as the next wave beyond mid-band FWA.

Start early with trials and pilots to identify most suitable deployment scenarios to add mmWave FWA.

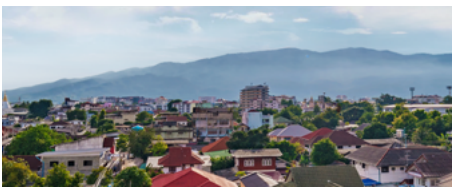

Urban regular cell range

← Diverse deployments →



Rural extended cell range

High band mmWave is growing spectrum band utilized in 5G, with 27 countries allocating licenses mmWave spectrum as of July 2024 according to GSA. According to GSA, the pricing of mmWave spectrum has been very attractive with \$/MHz/pop being 10x lower than the average 5G mid-band spectrum. The large amount of mmWave spectrum, typically 400-800MHz per service provider, make it very attractive for applications demanding high speeds and capacity such as FWA. Combining mid-band TDD with mmWave can even provide peak speeds of about 10Gbps and beyond in downlink and more than 2.2 Gbps in uplink.

→ <https://www.t-mobile.com/news/network/t-mobile-shatters-for-5g-uplink-speed>

Adoption of 5G FWA utilizing mmWave has been growing in interest. The GSA (4G/5G FWA Forum Survey 2025) forecast shipments of over 1 million mmWave-capable 5G CPEs in 2025, corresponding to about 5% of all 5G CPE shipments.

Although mmWave FWA is not yet mainstream, it is already used in diverse commercial deployments, from urban areas with regular cell ranges of few hundred meters, to rural areas with extended cell ranges up to 14 kilometers.

→ <https://www.ericsson.com/en/press-releases/2/2025/3/ericsson-nbn-co-and-qualcomm-achieve-5g-mmwave-breakthrough-extending-range-to-14-km-with-gigabit-speeds>

Verizon has been the pioneer of 5G FWA based on mmWave with the launch in late 2018. Since the acquisition of the mid-band spectrum, Verizon has adopted a mixed approach utilizing both mmWave and mid-band for FWA.

NBN Co has been serving rural households and business in rural Australia for over a decade. NBN covers around 800,000 premises with FWA, including 120,000 premises previously served within the nbn satellite footprint. Currently nbn has about 400,000 active FWA customers, of which around 10,000 served with mmWave.

There are many more service providers globally evaluating and testing mmWave-based FWA technology to augment capacity and/or to expand services.

One of the lessons learned from commercial deployments is that mmWave is unique in its ability to provide significant capacity and speed under the right circumstances. However, the propagation characteristics of mmWave spectrum are different, and mastering its full capacity requires time. Initiating trials and pilots

early on is crucial to identify the most suitable deployment scenarios when utilizing mmWave for FWA. Nevertheless, it is undeniable that the next wave of gigabit FWA will be driven by mmWave.

The combined use of mmWave and mid-band is the winning recipe, where mmWave serves household in good conditions and mid-band households in less favorable conditions. With the capacity offload enabled by mmWave, mid-band can serve even more households at more distant, challenging locations. This provides an opportunity to offer high-end wireless fiber services even in more rural areas, serve more households per radio site, as well as support higher data consumption. This unlocks the full business and technology potential of mmWave FWA, and is an attractive opportunity for a profitable use of mmWave spectrum combined with mid-band. A study from Ericsson shows that with the addition of mmWave, all homes will encounter higher data rates, with selected homes experiencing Gigabit speeds. Simultaneously, the total capacity will increase threefold.

→ <https://www.ericsson.com/en/reports-and-papers/ericsson-technology-review/articles/closing-the-digital-divide-with-mmwave-extended-range-for-fwa>

# nbn Fixed Wireless performance boosted by mmWave

## Challenging environment

- Australia is one of the largest continents in the world with huge variations in population density.
- nbn uses FWA to supply wholesale fixed broadband services, with a strict SLA, to homes and businesses in parts of regional, rural and remote Australia.
- The average residential data usage is around 500 GB per month.



## Technological advancements

- Upgraded LTE, as well as adding 5G in mid-band and mmWave.
- Expanded mid-band cell range from 14 km up to 29 km and mmWave extended range with reach up to 14 km.
- High performance with technician-installed CPEs.
- Automated and AI-power features to improve service qualification as well as customer experience management tools.



## Performance boost

- Increased network capacity and peak download speeds up to five times faster than previously available. New Superfast FWA offer with up to 400 Mbps DL speeds.
- Expanded coverage footprint to 800,000 premises, including 120,000 premises previously served by geostationary satellites. Currently about 400,000 active FWA customers, of which around 10,000 served by mmWave.

NBN Co owns and operates Australia’s national broadband network for the supply of wholesale fixed broadband services. Its purpose is to lift the digital capability of Australia, and it does so with an optimal mix of technologies. As a wholesaler, nbn relies on Retail Service Providers (RSPs) to deliver products and services to end customers, primarily through a layer 2 ethernet product using nbn fixed line, fixed wireless, and satellite technologies. Services are sold with a strict service level agreement (SLA). The average residential data usage is about 500 GB/month.

Australia is one of the largest continents in the world with huge variations in population density. nbn uses Fixed Wireless Access services to deliver high-speed broadband to customers in parts of regional, rural and remote Australia. Outdoor CPE are used to meet minimum service quality requirements. Professional installation is used in 100% of cases. NBN

Co owns the CPE as it is the wholesale Network Termination Device. It presents a layer 2 bitstream ethernet service towards the retail service provider’s residential modem/gateway.

NBN launched a LTE based FWA network in 2012. In 2024, nbn completed a program to upgrade the capacity, reach and speed of its FWA network by significantly increasing the LTE capacity as well as adding 5G in both mid-band (2.3GHz and 3.4GHz) and mmWave (28GHz). The program involved upgrading equipment to more than 2,300 fixed wireless infrastructure sites, of which 850 sites with mmWave as of 2Q25.

The upgrade enabled nbn to more than double the transmission radius using mid-band spectrum from 14 kilometers to 29 kilometers. NBN now covers around 800,000 premises with FWA, including 120,000 premises previously served within the nbn satellite footprint. Currently nbn

has about 400,000 active FWA customers, of which around 10,000 served by mmWave.

FWA now offers increased network capacity and peak download speeds up to five times faster than previously available. FWA wholesale plans: Fixed Wireless Plus (up to 100/20Mbps), Fixed Wireless Home Fast (up to 200-250Mbps/8-20Mbps) and Fixed Wireless Superfast (up to 400/10-40 Mbps).

As part of this modernization, nbn also brought in new technological advancements such as mmWave extended range with reach up to 14 kilometers, and a new generation of outdoor CPEs. Moreover, nbn has implemented automated and AI-power features to improve service qualification as well as customer experience management tools.

\*Note that speeds referred to are nbn’s wholesale speeds.

# Scale of open 3GPP ecosystem delivers FWA with lowest TCO and future-proof evolution

To be competitive, FWA service providers need to be able to offer data at the lowest possible Total Cost of Ownership (TCO) with a future-proof evolution of the network and the entire broad ecosystem. 3GPP offers all this through three main aspects:

## Network platform

- MBB anchor use case, main funding for spectrum and site/coverage
- Multi-service: MBB, FWA and IoT
- Spectrum shared with slicing

3GPP offers a network platform where mobile broadband (MBB) is the anchor use case, and has funded large parts of the site infrastructure and spectrum costs. Most incumbent 3GPP service providers are in an advantageous starting position, since they can reuse the entire mobile network, and much of its business processes, to offer multiple services, including MBB, FWA and IoT. The spectrum can be shared, and network slicing offers a way to manage both network and spectrum across multiple services, while meeting or exceeding the emerging requirements of a wide range of use-cases (including 5G FWA).

## Device ecosystem

- Affordable devices leveraging 3GPP chipset ecosystem
- Broad device ecosystem with nearly 100 CPE device vendors

The 3GPP CPE ecosystem benefits from the large innovative smartphone and device chipset market. Costs are driven down by economies of scale, and the availability of LTE and 5G FWA CPE with attractive form-factors and functionality evolution. The GSA has identified 80 5G FWA CPE vendors, with over 350 5G FWA CPEs announced (GSA, December 2025).

## Innovation ecosystem

- Open technology and multivendor
- Future proof technologies including evolution to 6G
- Global spectrum allocation

A further advantage of 3GPP is a future-proof ecosystem that ensures innovation combined with scale and cost-efficiency. 3GPP also offers an open technology platform with multiple vendors, without lock-in. Furthermore, it ensures global licensed spectrum allocations, further driving economies of scale for both network equipment and the entire FWA CPE ecosystem.

In summary, 3GPP mobile and converged service providers are in an excellent position to address the FWA market. They will be able to offer services with the lowest possible TCO, and provide a future-proof evolution of the network and corresponding FWA services, coupled with a broad ecosystem that offers economies of scale and no-vendor lock-in.

# FWA is an integral part of 6G, enabling new capabilities, performance and capacity

**Evolution of the network platform**

Introduce 6G

Expand 5G, Ready for 6G

Introduce 5G Advanced

**6G in new and existing 3GPP spectrum**

Intelligent multi-layer frequency co-ordination

mmWave (24...47 GHz)

cmWave (7...15GHz)

Midband TDD (2.3...<7 GHz)

Midband FDD (1.. 2.7 GHz)

Lowband FDD (<1 GHz)

**6G capabilities**

FWA will benefit from 6G capabilities such as

- Enhanced uplink performance
- Optimized spectrum utilization
- Predictable and guaranteed latency
- Evolved differentiated connectivity
- Native AI, intent-based and programmable

FWA specific enhancements also explored for 6G

Increasing capacity by adding new cmWave spectrum with Massive MIMO on the existing site grid

6G is the name for the sixth generation of cellular networks. Delivering extraordinary performance and an evolution of the multi-purpose network platform, 6G will bring a new era of connectivity and possibilities across telecom, technology sectors, wider industry and society. It will enable new revenues, extend end-user benefits and evolve technology components.

The first commercial 6G services are expected around the year 2030, with pre-commercial trials expected from about 2028 and early proof of concepts even earlier. The standardization process for the first 6G standard has already started based on several years of research. Learnings from live 5G networks and interactions with the user ecosystems will continuously feed into the research, standardization and development of 6G.

FWA is a very successful use case of 3GPP-based networks and is an integral part of the 6G scope. 6G will build on 5G, evolving from today's networks towards the needs of 2030 and beyond. The first wave of 6G will advance technologies and use cases already introduced in the 5G era, delivering essential support for key services and deployment scenarios from day one.

This includes enhancements to network exposure, programmable networks, and use cases like enhanced mobile broadband (eMBB), fixed wireless access (FWA), and the Internet of Things (IoT).

### 6G in new and existing spectrum

6G spectrum is driven by expected demands on future mobile networks beyond 5G Advanced. This includes anticipated 6G use cases that are expected to require more capacity and coverage than those of the 5G era. The ongoing exponential growth of data traffic is another key driver. This means additional spectrum will be crucial to ensure continued cost efficiency and performance for existing use cases such as mobile broadband, fixed wireless access (FWA), and mixed reality.

6G will be built on a broad layer cake of spectrum that spans today's existing grid of low-, mid- and millimeter wave bands (mmWave), underpinned by new frequency bands in the centimetric wave (cmWave) range 7-15 GHz, of which sub-10GHz is the most promising.

Higher spectral efficiency combined with highly efficient multi-RAT spectrum sharing (MRSS) between 6G and 5G will be key to making efficient use of limited low- and mid-band spectrum supply, as serving an exponentially growing traffic demand in a cost-efficient way.

### Increasing capacity by adding new cmWave spectrum with Massive MIMO on the existing site grid.

The cmWave bands will underpin the vast majority of 6G deployments already from day one. With close proximity to today's mid-band TDD range, cmWave offers good propagation characteristics for use cases that demand wide-area coverage with high capacity, such as FWA.

### 6G capabilities

Uplink-downlink decoupling is an example of more advanced handling of multiple carriers in 6G. Given the difference in transmit power and antenna configurations, a device in a location



with less favourable radio conditions could sometimes be better served if it could transmit in a lower frequency band but receive high-speed data on wider bandwidth in a higher frequency band.

MIMO is another example where 6G will enhance the performance compared to 5G. In the downlink, MIMO will become even more massive with thousands of antenna elements. The existing mechanism for reporting channel-state information from the device to the base station needs to be reconsidered to address this. In the uplink, multi-layer transmission and beamforming will be more important than in 5G, for example to address use cases such as fixed wireless access.

Both 4G and 5G support carrier aggregation, which also improves the data rate by utilizing more spectrum resources and multiple carriers for data transmission,

but in a somewhat limiting manner. For example, the time it takes to configure and activate additional carriers in 4G/5G can be relatively long, meaning that the data may already have been transmitted by the time all carriers are activated in the device. In 6G, improved performance could therefore be achieved by quicker setup for faster access to a larger transmission bandwidth for (high-end) devices supporting carrier aggregation.

6G will further advance the performance, service differentiation and guarantees. An entirely new wave of use cases and devices will be made possible by 6G technologies.

Through AI-native capabilities, 6G will take the industry significantly closer to intent-based fully autonomous network operations with zero human touch.

FWA is a relatively large part of

the overall data volume for many communication service providers. FWA can be supported by the generic 6G Radio Access Technology (RAT) and will benefit from many of the 6G capabilities. FWA specific enhancements should also be explored for 6G. A higher device output power and exploiting the fact that the device is not moving to better exploit multi-user MIMO are two examples of what can be done to further improve the performance.

For more on 6G see:

→ <https://www.ericsson.com/en/6g>

→ <https://www.ericsson.com/en/6g/spectrum/cm-wave>

Read all nine insights  
on capturing the value  
of 5G FWA

[ericsson.com/fwa-insights](https://ericsson.com/fwa-insights)