



ERICSSON

DYNAMIC SERVICE CHAINING WITH SDN

DYNAMIC SERVICE CHAINING WITH SDN

The Ericsson Dynamic Service Chaining solution uses Software Defined Networking (SDN) technology to provide network service providers end to end tools that simplify integration and management of network service functions. Service Providers can use this solution to build rapidly scalable agile networks while simultaneously optimizing the usage of compute and networking resources – consequently increasing their return on assets. The Ericsson Dynamic Service Chaining Solution is a key ingredient that enables end-user service personalization and deployment of massively scalable Virtualized Network Functions (VNF).

Problem Statement

Service-Provider networks today provide a number of service functions such as firewall services, content filtering and HTTP header enrichment, web servers and streaming services. Managing the operations of these services, such as adding new services or increasing capacity of a service, often requires reconfiguration of multiple routers, switches and application servers – a process that is complex, inflexible and prone to inconsistent configurations – often delaying deployment of services. These services are generally massively overprovisioned because all traffic in the network traverses each of the services even though only a subset of the services may be relevant for each of the traffic flows in the network. Service providers are increasingly embracing breakthrough innovations in cloud computing and are looking for ways to build agile, flexible and reliable network services that are simple to manage, efficient to operate and enable rapid creation of novel personalized consumer services that can potentially create new revenue opportunities.

Ericsson Solution

The Ericsson Dynamic Service Chaining solution uses SDN technology to intelligently chain service functions so that traffic from each subscriber only traverses a particular set of service functions as defined by the policy for that particular subscriber. This solution can also be used to apply service chaining policies to operator/user defined services. For example, an operator can configure a service chaining policy such that only web traffic is sent to a content optimization service.

This solution is integrated with a management and orchestration system that greatly simplifies configuration and management of service chains – the

traffic path for any arbitrary flow can be dynamically changed by simply changing the policy associated with that flow – the SDN controller automatically programs routers, switches and application servers in the network.

Using the capability to selectively steer certain portions of the network traffic to a specific set of services provides operators the benefit of optimally utilizing compute and network resources, thereby relieving them from having to continuously overprovision service-function capacity. As a proof point of this benefit, in one study with a Tier-1 service provider, Ericsson showed that deploying an SDN based service chaining solution to provide parental control services would reduce the capital expenditures (CAPEX) for the service by 80%.

The Ericsson Dynamic service chaining solution proves to be an invaluable tool that helps operators improve the reliability of their network operations while reducing the operating expenses (OPEX). In a study with a Tier-1 mobile operator, Ericsson demonstrated that the typically risky and disruptive process of upgrading services can be made far less risky if the newer versions of the software can be thoroughly tested in the live network by redirecting only a small subset of traffic to the new version of the service using SDN technology, instead of fork lifting the upgrade. Such a capability allows service providers to quickly revert back to stable versions of software, when required, with a simple change in the service chaining policies. Ericsson demonstrated that using the dynamic service chaining solution would help the operator save 30% of the OPEX related to upgrading and troubleshooting their network elements. The Ericsson Dynamic Service Chaining

Providing parental control services using SDN based service chaining could reduce the capital expenditures (CAPEX) for the service by 80%.

solution uses open interfaces and an open platform – service providers can now benefit from and contribute to the rapid pace of innovation in the SDN ecosystem and count on unparalleled multi-vendor interoperability in a service provider network. Ericsson leverages its world class integration and services capability to provide service providers with end to end network solutions and services that enable them to rapidly deploy, manage and differentiate their service offerings. Utilizing the above capabilities of the Ericsson Dynamic Service Chaining solution not only simplifies network operations, but also allows service providers to rapidly introduce and scale services. Consistently improving network agility and time to market of services creates a sustained differentiating advantage for an operator that directly translates to a significant and persistent revenue advantage over the operator's competitors.

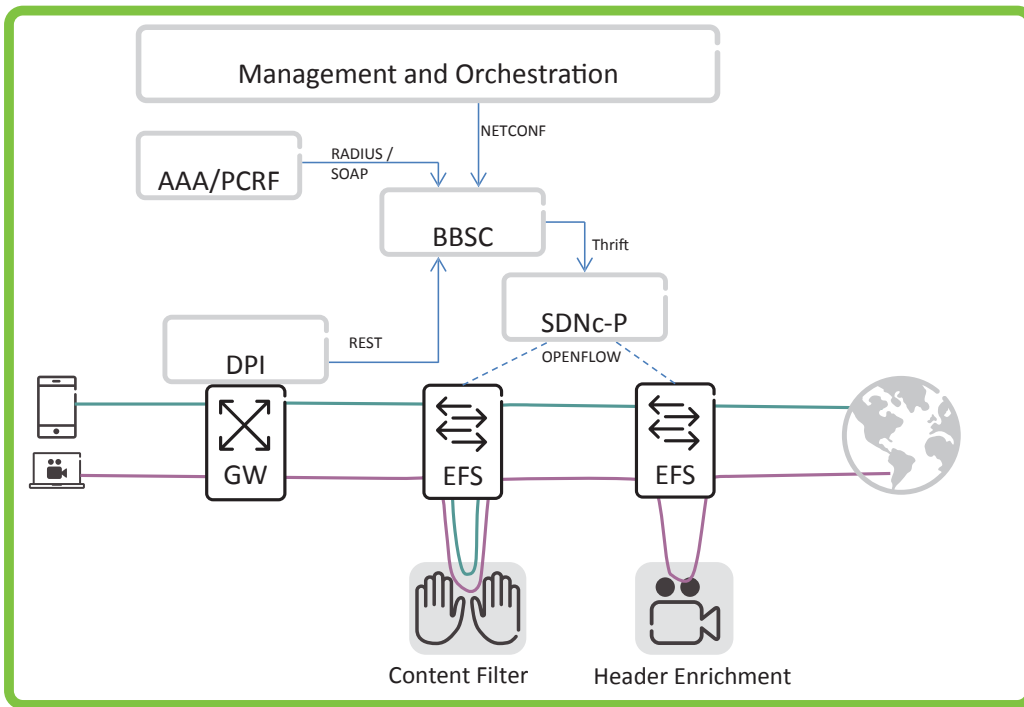

Abbreviations

- AAA
Authentication Authorization and Accounting
- BBSC
Broadband Service Controller
- DPI
Deep Packet Inspection
- EFS
Ericsson Flow Switch
- GW
Gateway
- SDN
Software Defined Networking
- SDNc-P
SDN Controller Platform

Ericsson Dynamic Service Chaining solution uses open interfaces and an open platform – service providers can now benefit from and contribute to the rapid pace of innovation in the SDN ecosystem

Solution Components

The Ericsson Dynamic Service Chaining solution is built upon the Ericsson Service Provider SDN solution. This solution is comprised of the following key elements:

Ericsson SDN Controller Platform (SDNc-P)

The Ericsson SDN Controller Platform, based on OpenDaylight platform, is an open platform that enables network programmability. It provides open northbound (programmatic) and southbound (implementation) interfaces and has been designed to be fully pluggable and extensible – fostering rapid innovation and flexibility.

The Ericsson SDN Controller Platform uses the OpenFlow and NETCONF protocols to the flow switches in the service provider network. The SDN Controller centralizes control of numerous SDN flow switches in the network. It aggregates analytics from all the flow switches in the network and leverages the information to help debug problems in the network and provide valuable insights about traffic in the network. This platform runs on an off the shelf hardware platform.

Ericsson Broadband Service Controller (BBSC)

The Ericsson Broadband Service Controller is a network function that controls the traffic steering of the subscriber data traffic along several service functions in the operator's service network. The Ericsson Broadband Service Controller makes dynamic service chaining decisions and configures the underlying hardware and software elements in the network based on information it obtains from a plurality of support nodes, including subscriber policy management systems (PCRF), authentication systems (AAA), Network Management Systems (NMS) and Deep Packet Inspection (DPI) systems. The Ericsson Broadband Service Controller runs on an off the shelf hardware platform.

Ericsson Flow Switch (EFS)

The Ericsson Flow Switch is an OpenFlow protocol compliant SDN

switch that can run either as a software function on the SSR 8000 router platform, as a software module running within a hypervisor or as a stand-alone virtual machine within a cluster. The Ericsson Flow Switch on the SSR 8000 platform offers industry leading performance and scalability allowing SDN deployments in demanding environments such as the network edge where millions of subscribers and traffic flows are simultaneously active at any given time.

Ericsson Dynamic Service Chaining Solution



Uses SDN technology to enable service providers easily deploy personalized end user services.



Provides operators the benefit of optimally utilizing compute and network resources – relieving them from having to continuously overprovision network service function capacity.



Uses open interfaces and an open platform – service providers can now benefit from and contribute to the rapid pace of innovation in the SDN ecosystem.



Supports the Ericsson Flow Switch on the SSR 8000 platform that offers industry leading performance and scalability.



Enables service providers to rapidly deploy, manage and differentiate their service offerings thru Ericsson's world class integration and services capability.

Ericsson is the world's leading provider of communications technology and services. We are enabling the Networked Society with efficient real-time solutions that allow us all to study, work and live our lives more freely, in sustainable societies around the world.

Our offering comprises services, software and infrastructure within Information and Communications Technology for telecom operators and other industries. Today more than 40 percent of the world's mobile traffic goes through Ericsson networks and we support customers' networks servicing more than 2 billion subscribers.