

# bulletin

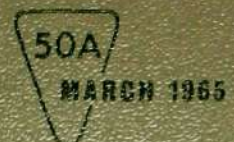

ERICSSON TELEPHONES LIMITED

ETELCO LIMITED



# 'PENTEX'\*

## A SMALL ELECTRONIC EXCHANGE

\*Trade Mark

### CONTENTS

Page 4	Introduction	Page 20	Registers
Page 5	Outline of Operation	Page 23	Supervisory Relay Sets
Page 7	Definitions	Page 25	Calling Number Generation
Page 8	Facilities	Page 27	Call Control
Page 9	Reliability and Service Security	Page 28	Selectors
Page 12	Trunking	Page 31	Equipment Practice
Page 15	Control	Page 33	Reed Relays
Page 17	Cross-Point Switches	Page 34	Power Supplies



**ERICSSON TELEPHONES LIMITED  
ETELCO LIMITED**

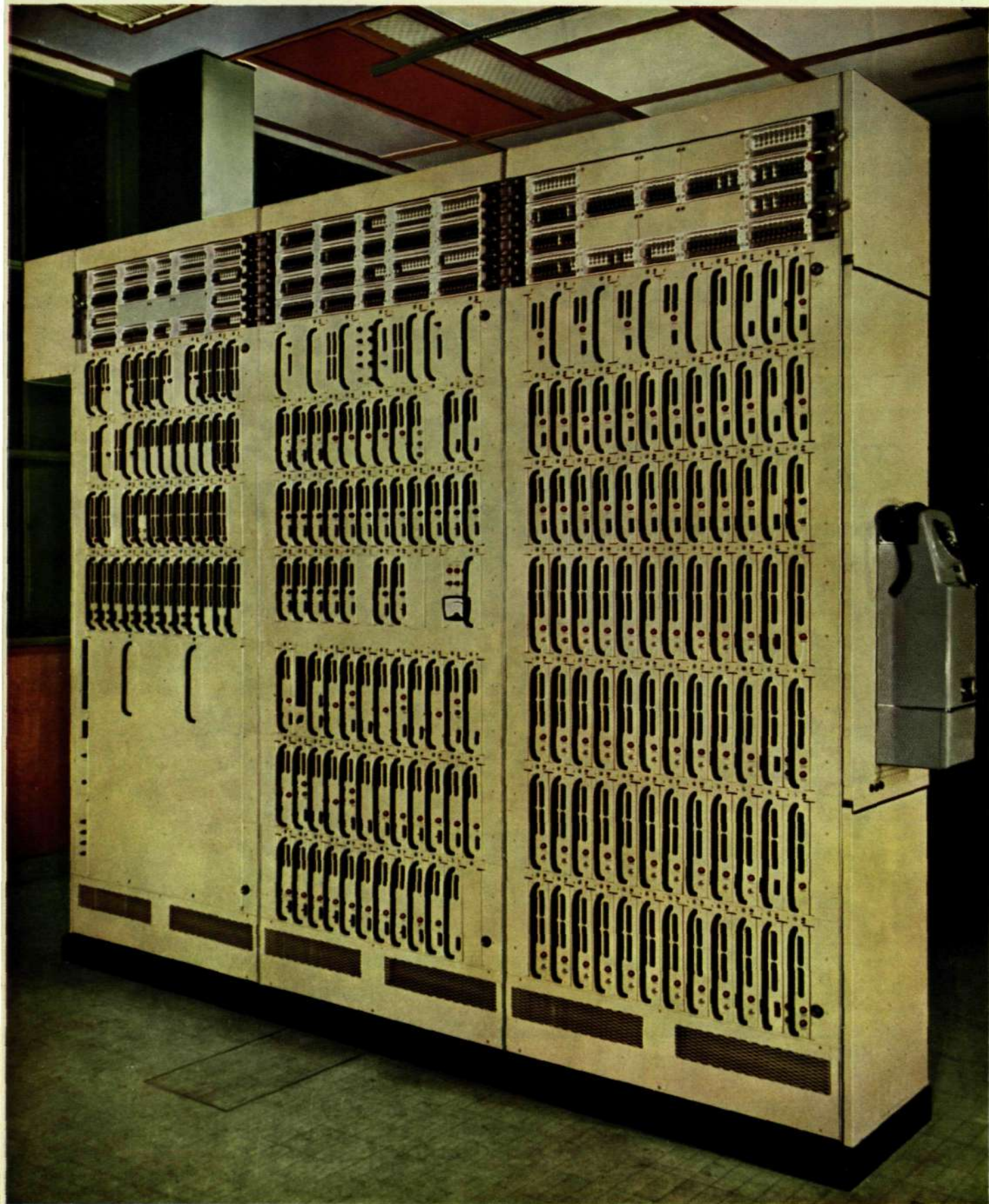

The prototype Pentex Exchange ready for installation at Peterborough

(The coin-box telephone is for demonstration purposes at this exchange)

# PENTEX

## A Small Electronic Exchange

This special issue of the '*Bulletin*' has been prepared to coincide with the first field trial in public service of the PENTEX electronic exchange system. The system is designed specifically for small exchanges; it is compatible with existing electro-mechanical exchanges and is the basis of the small electronic exchange system which is being put into production for the British Post Office.

Under the terms of a Joint Electronic Research Agreement, the Company and other manufacturers have collaborated with the British Post Office in developing a number of electronic switching systems including 2 and 4-wire time-division multiplex and reed relay space division. An assessment has shown that these systems cannot be applied economically to the small electronic exchange. A more appropriate solution has been achieved with PENTEX using reed relays and a different arrangement of control equipment.

PENTEX caters primarily for exchanges between 200 and 1,200 lines, although the design permits both larger and smaller exchanges to be produced.

## INTRODUCTION

Because of the very high standard of efficiency reached in the design of electromechanical exchanges, it has been evident for some time that any significant progress in telephone switching requires the application of new techniques. For this reason, considerable effort has been devoted to the exploitation of advances in electronic switching methods which offer an attractive alternative to conventional switching. A recent outcome of this effort is the Pentex exchange.

Considerable interest in Pentex has already been shown by home and overseas visitors and this interest has been further stimulated by a short article written jointly by Mr. J. A. Lawrence of the British Post Office, Mr. J. R. Pollard of Plessey Group Management Limited and members of the Company's staff, which has appeared elsewhere.<sup>1</sup> This article sets out the background to the development of the Pentex system and recalls that it has been developed by the Company in conjunction with the British Post Office as part of a contribution to the programme of Research and Development organized by the Joint Electronic Research Committee.<sup>2</sup>

Pentex equipment for 200 subscribers is about to be installed at Peterborough for a field trial in public service, and it has recently become known that, subject to meeting the Post Office requirements, Pentex will go into production as the British Post Office approved

electronic system for installations within its traffic capacity. A contract for the first production exchange has already been received, and others are currently under consideration.

In the Pentex system, reed relays are used throughout for the switching of speech paths, which are entirely metallic, and control operations are performed by reed relay and semiconductor circuits. The response of these circuits is fast enough to enable a single set of control equipment to handle all the calls passing through the exchange. However, because this is 'common equipment', it is duplicated to ensure continuity of service in the event of equipment failure.

The method by which the Pentex exchange establishes connection between subscribers is analogous to the principle employed in a 'cordless' switchboard (a switchboard in which connections are made by the operation of keys only). Wiring multiples, one connected to each of the input terminals of the switching matrix, cross the path of all the wiring multiples connected to the output terminals. At each crossing point provision is made for connecting together the two crossing wiring multiples and hence the associated input and output terminals. In the cordless switchboard the connecting is done by keys; in the Pentex exchange it is done by reed relays.

The contacts used in the reed relays are individually sealed in glass tubes and are therefore protected from atmospheric contamination. The contact units are of simple construction and their adjustment remains constant throughout their life. These two factors combine to give high reliability while maintaining the advantages of a metallic speech path.

The common control equipment enables the availability of a wanted subscriber to be determined without setting up a speech path; the speech path is set up only when it is known that the call is likely to be completed. It also makes easier the application of some of the special facilities. For instance, test and trunk-offering facilities can be included without the need to provide an additional switching network.

The design of the Pentex exchange, embracing the use of semiconductors, reed relays and common control circuits, makes it compatible with existing step-by-step and other electromechanical exchanges, comparable in cost, and able to offer more facilities and higher reliability.



**Figure 1—Col. W. E. Gill (right), Telephone Manager of the Peterborough Area, examining a circuit from the prototype Pentex Exchange under construction**

<sup>1</sup>Lawrence, J. A., Pollard, J. R., Matthews, G. A. and Nicholson, N., 'Pentex', A New Electronic Telephone Switching System', *British Communications and Electronics*, Vol. 12, No. 1 (January 1965), pp. 42-44. Reprints available on request.

<sup>2</sup>On this committee the Company is associated with Associated Electrical Industries Ltd., Automatic Telephone and Electric Co. Ltd., General Electric Co. Ltd., Standard Telephones & Cables Ltd., and the Research and Engineering Branches of the Post Office.

Since going to press we have learned of the death of Colonel W. E. Gill, the Telephone Manager of the Peterborough Area, whose photograph appears on page 4 of this issue.

We at Ericsson Telephones Limited take this opportunity to associate ourselves with his many friends in the Post Office in expressing our deepest sympathy and would like to acknowledge with gratitude his support and assistance in making arrangements for the field trial at Peterborough.

## OUTLINE OF OPERATION

Subscribers' lines to the exchange are terminated on line circuits as in a step-by-step exchange. The junctions which connect the exchange to other exchanges, and over which outgoing and incoming calls are made, are terminated on supervisory relay sets. These control the call both during and after its setting-up period. During the setting up of a call the supervisory relay set which is handling the call is connected to a register, whose functions include the storage of the calling subscriber's number and the counting and storage of the dialled digits. The connections between subscriber, supervisory relay set and register are shown in simplified form in Figure 2.

The speech path between subscribers and supervisory relay sets is set up via cross-point switches (designated A, B, C and D), consisting of reed relays built up in a co-ordinate array. The basic switch is a matrix of 25 relays ( $5 \times 5$ ), and the largest of the switches, the A-switch, consists of an array of basic switches in rows of five; the number of rows, and hence the number of subscribers which can be connected, is determined by their calling rate.

The connection of subscribers to supervisory relay sets could be achieved by using one large cross-point switch with all the subscribers connected to, say, the horizontal multiples, and all the supervisory relay sets to the vertical multiples. This would ensure that any subscriber could always gain access to any free relay set, but the switch would be costly to produce since it would contain a large number of reed relays. Greater economy with adequate availability can be obtained by replacing the one large switch by a number of smaller

switches employing a much smaller total number of reed relays. A satisfactory balance between cost and grade of service can be achieved by using three switching stages (A, B and C) for outgoing calls and four switching stages (D, C, B and A) for incoming calls, the number of each type of switch depending on the size of the exchange and the traffic rate. For an exchange with 200 subscribers and 40 supervisory relay sets, a single switch would employ 8,000 reed relays, whereas a good grade of service using A, B, C and D switches can be obtained with about 2,000 relays.

The way in which the switches are inter-connected, and the smooth growth pattern which can cater for increasing traffic, are shown in Figure 6 and described in the section headed 'Trunking'. A block schematic of the whole exchange is shown in Figure 7 and the use of the various circuits in setting up a call is described in detail in the section headed 'Control'.

### SETTING UP A CALL

Briefly, the sequence of events in setting up a call is as follows.

The subscriber, on lifting his handset, causes his own number to be generated electronically and stored in a register. If on this exchange calls to and from other exchanges predominate, a path is selected between the subscriber and a main-exchange supervisory relay set (connected to an outgoing junction). When the path is switched, dial tone is sent from the register to the subscriber, and dialling can take place.

As the subscriber dials, the transmitted pulses are counted and stored in the register and simultaneously repeated to the main exchange via the supervisory

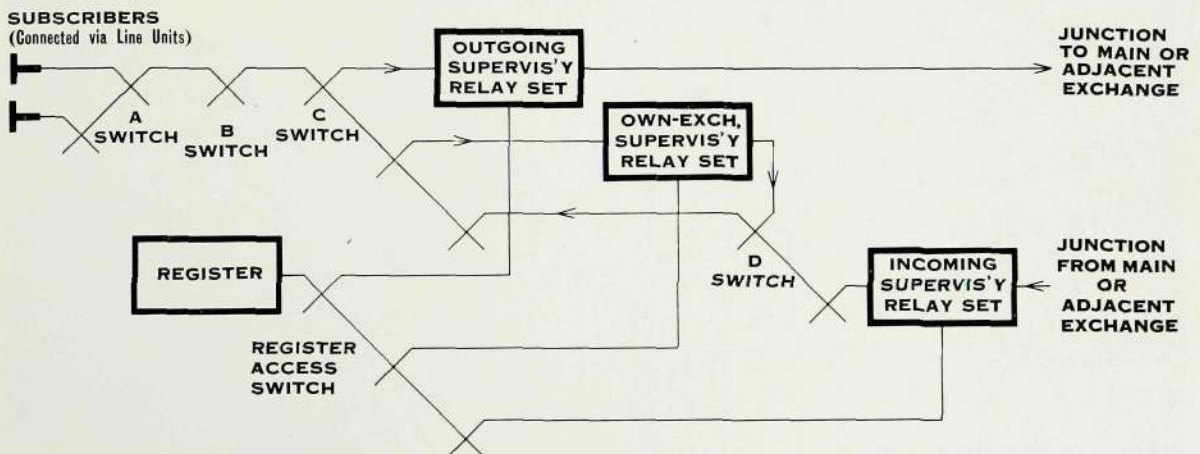

Figure 2—Simplified block diagram of a Pentex Exchange

relay set; (in a typical area 80 per cent of the calls in an exchange go to other exchanges). As dialling proceeds, the register, in conjunction with the router, determines whether the call is for the main exchange or is to be completed locally. If it is to the main exchange (or to an operator, another exchange or the trunk dialling network reached via the main exchange) the register is released and dialling continues over the already established path. Conversely, if the dialled information indicates that the call is to be completed in the local exchange, the existing path from the subscriber to the main-exchange supervisory relay set and the register is released. A new path is established by an exactly similar process to the setting up of the original path, but this time making use of an 'own-exchange' supervisory relay set.

The release and new setting-up operation takes about 50 ms and so can easily be completed between

successively dialled digits. As the subscriber continues to dial, in the case of an own-exchange call, the register counts and stores further digits until, by means of the decoder, the called subscriber can be identified. A signal over a common test lead indicates to call control whether the wanted subscriber is engaged or free; if engaged, busy tone is sent to the calling subscriber from the register. If free, a marking and setting-up process similar to the original one takes place whereby the supervisory relay set is connected via D, C, B and A-switches to the called subscriber. (The D-switch is included to give a better distribution of terminating traffic.) Ringing signals are then applied, and connection between the two subscribers is established when the called subscriber lifts his handset.

An incoming call from another exchange is processed like the terminating set-up of a local call, making use of the register, etc., to determine the wanted subscriber.

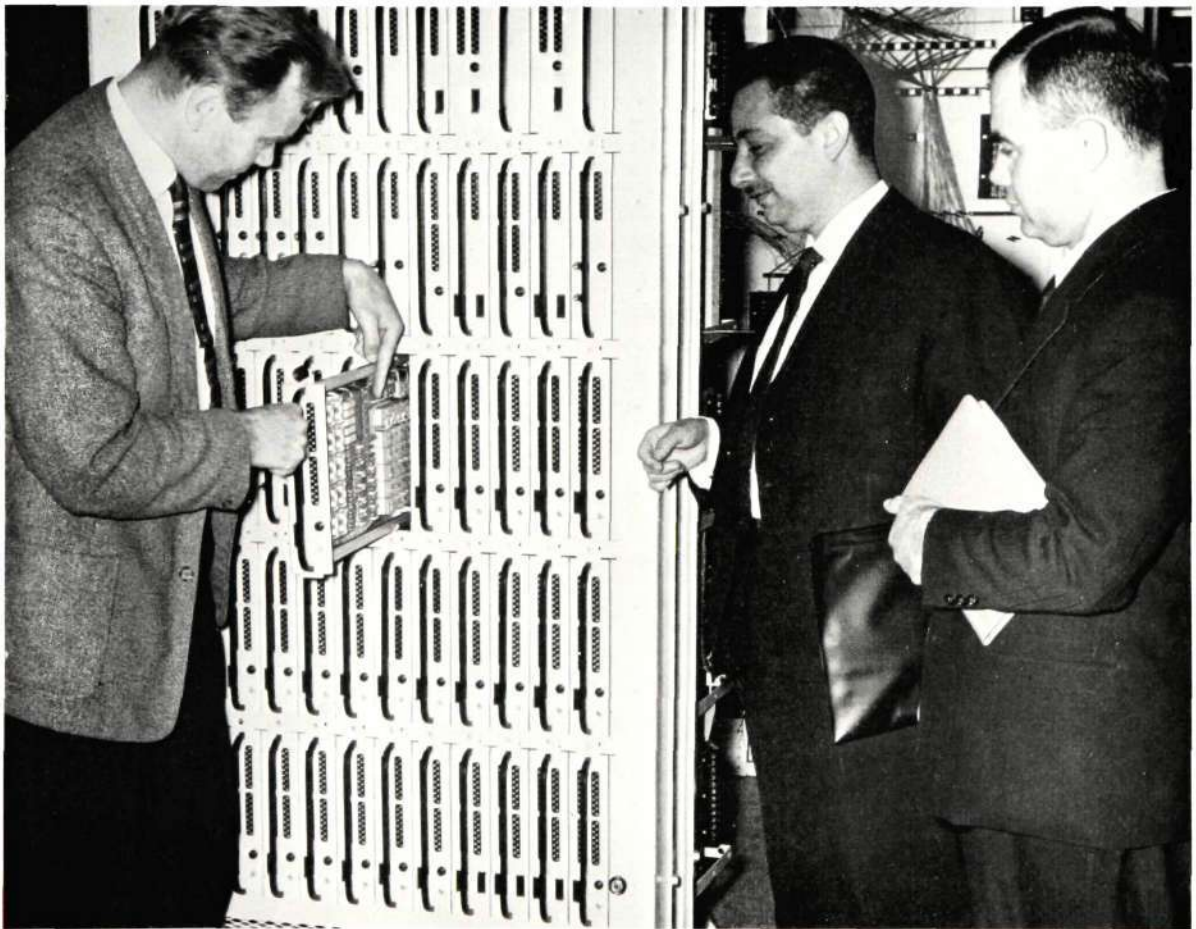

Figure 3—Messrs. A. S. Attasi and U. Haffar of the Syrian P.T.T. Department examining a rack of Pentex equipment

## DEFINITIONS

### **Access Relays (Figures 9 and 10)**

Relays which connect to a switch selector circuit the control wires associated with the paths through a switch.

### **Call Control**

A circuit which monitors and controls each call at critical points during its setting-up. Since each operation of call control is brief (several milliseconds) one circuit serves for all calls.

### **Calling Number Generator (Figure 16)**

An array of metal-tape cores acting as pulse transformers, and threaded by a wire from the subscriber's line circuit in a way unique to each subscriber. A calling pulse along the wire generates outputs from the secondary windings of the threaded cores in a combination which identifies the calling subscriber.

### **Calling Number Store (Figure 16)**

An array of ferrite cores whose 'square-loop' characteristics enable the cores to store the information produced by the calling number generator. The stored information is later transferred to a register.

### **Control Allotter**

*(Also known as a Register Finder)*

A circuit which connects a register to call control. In the event of two or more registers simultaneously requiring connection to call control, the control allotter chooses one of them, giving priority to a register which is dealing with an incoming call.

### **Class-of-Service Amplifier**

Class-of-service information relating to a particular subscriber is generated in a similar way to the calling number, by pulse operation of metal cores. The output signals from the secondary windings are amplified in the class-of-service amplifiers which then convey the information to supervisory relay sets, registers, or call control as required.

### **Cross-Point Switch (Figures 5, 8, 9, 10, 11, 13 and 18)**

A circuit which contains a number of inputs connected to horizontal wiring multiples, and outputs connected to vertical wiring multiples. Connection can be made between any one of the inputs and any one of the outputs by connecting the associated horizontal and vertical multiples at the point where they cross. The cross-point connection is made by contacts of a reed relay.

### **Decoder**

Calling and called directory numbers are stored in two-out-of-five code. The decoder converts the number to a potential on a specific subscriber's line, thereby identifying and marking it.

### **Register (Figure 12)**

A circuit which is in use for the duration of the setting-up process of a call. It stores the calling and called numbers and passes the stored information to the decoder or router as required. Other functions include counting dial pulses and connecting dial, N.U. and busy tones to the calling subscriber.

### **Register Access Switch**

This connects one of a number of registers to one of a number of supervisory relay sets.

### **Router**

On receipt of dialled digits from the register, the router determines whether the call is local or trunk, and passes this routing information to call control and the outgoing supervisory relay set.

### **Selector**

A circuit employing logic elements which select a path via the cross-point switches between a subscriber and a supervisory relay set. (The control and store allotters have circuits similar to a selector.)

### **Store Allotter**

*(Also known as a Register Selector)*

A selector circuit which chooses a free register for connection to the calling number store.

### **Subscriber's Line Circuit (Figures 8, 17 and 18)**

A circuit connected to each subscriber's line, to detect a calling loop and produce the pulse which generates the calling subscriber's number. On incoming calls, the line circuit signals to call control the state of the called subscriber's line. Five line circuits are mounted together to form a subscriber's line unit.

### **Supervisory Relay Sets (Figures 14 and 15)**

Circuits which are associated with a call for almost the whole of its duration. They are of three types and are connected either to outgoing or incoming junctions, or, for own-exchange calls, between C and D-switches. Functions of the relay sets include the repetition of dial pulses, connection of ring tone and ringing current, and the relaying of meter pulses; the specific functions depend on the type of relay set in use.

## FACILITIES

The Pentex electronic exchange provides all the facilities offered by a step-by-step exchange. Some of these are provided in conventional form, while others are achieved by improved methods. In addition, new facilities are incorporated.

### Conventional Facilities

- Test and Trunk Offering
- Barring of Trunk Calls
- Centralized Service Observation

### Improved Facilities

- Barring of Outgoing and Incoming Calls
- Coin and Fee Checking Equipment
- Fault Checking and Indication
- Shared-Service Working
- PBX Working

### New Facilities

- Displayed Identity of Calling and Called Line
- Call Tracing
- Flexibility of Equipment Numbering
- Easy Class-of-Service Alteration
- High Speed Dialling
- Acceptance of Push-Button Telephone Working

Among the improved facilities, barring of outgoing or incoming calls is easily imposed by associating the particular line with the OCB or ICB class of service.\* The only change needed to the equipment is the re-threading of the lead through the class-of-service field to include the OCB core, the ICB core, or both.

The coin and fee checking equipment is the same as that normally used by the British Post Office. In the Pentex exchange, however, it can be brought into use on transferred-charge incoming calls.

A considerable amount of automatic fault-checking and indication is carried out. In many cases action is taken if a circuit does not complete its function in the allotted time, thereby preventing a second call suffering from the same fault. The exchange is designed so that, where possible, the 'busy out' of faulty circuits reduces grade of service generally rather than putting particular subscribers out of service.

Party discrimination in shared-service working is a function of the register, enabling the line to be 'busied'

immediately it is looped. This prevents the possibility of two paths being partially set up, one by each party, a condition which can occur in step-by-step exchanges. In addition the possibility exists of designing the circuit to enable the two parties of a shared-service line to dial each other.

The improvement in the PBX facility lies in the fact that numbers in a PBX grouping need not be consecutive. This gives greater flexibility in the allocation of exchange numbers and removes the necessity of reserving groups of numbers for possible PBX extensions.

### Displayed Identity of Lines (Figure 4)

Since the calling number and the dialled digits are stored in a register in directory number form, they can be readily determined by connecting the register's stores to a display unit. The number is converted from two-out-of-five to decade form and is displayed on Digitrons.†

### Call Tracing

The application of a phased signal to a test point on an A-switch causes a neon lamp to flash on the supervisory relay set to which the A-switch is connected. Similarly, determination of the A-switch connected to a particular supervisory relay set can be achieved. Additionally, by the use of a plug-in tester it is possible to trace the path of the call through the switches. By these means a call can be traced much more easily and quickly than by the conventional method of observing switch outlets and consulting grading charts.

### Flexibility of Numbering

Because a calling subscriber is identified by the number produced by the calling number generator, his number is not determined by the physical location of equipment in the exchange. This means that, to cater for changing traffic conditions, subscribers can be re-connected to a different section of the exchange without the necessity of changing their numbers.

### Class of Service

Classes of service are determined by the routing pattern of jumper leads threaded through cores in the class-of-service field. These leads also convert directory number to equipment number. As already mentioned in connection with the barring of calls, the

\*Outgoing or incoming calls barred

†Registered Trade Mark

addition or removal of any class of service is simply achieved by re-threading a jumper lead through the required combination of cores.

### High Speed Dialling

Because dial pulses are counted electronically, the pulse repetition rate is no longer restricted to 10 p.p.s. This allows the use of higher speed dials or dials with a much wider speed tolerance, and keysending devices, which would provide a useful reduction in the dialling time of S.T.D. numbers, and hence in the holding time of registers.

### Push-Button Telephones

Provided that the operation of push-buttons is sequential, the digit store can receive digits at the highest practical rate at which they can be transmitted, thus eliminating the need for pauses between the operation of push-buttons. One form of push-button dialling employs audio frequencies in a two-out-of-five code. Digital information in this form is of course readily handled by the exchange since it already stores conventionally dialled digits in two-out-of-five code.

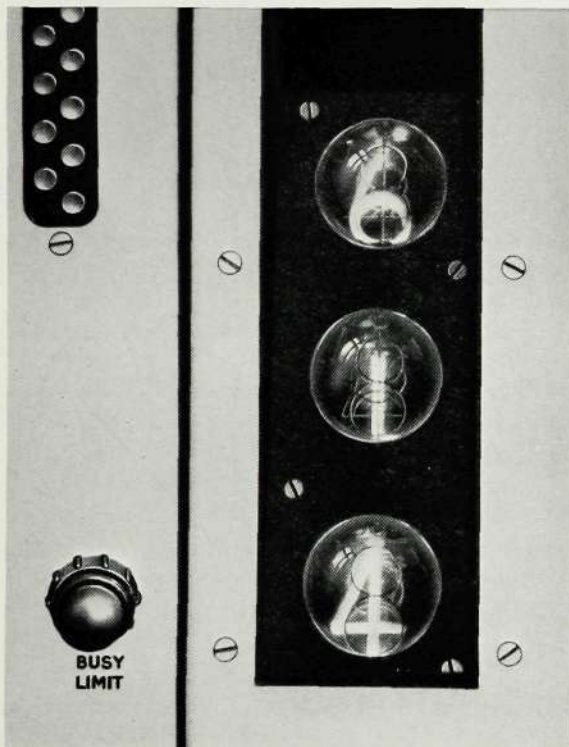

Figure 4—Number Display Unit. The self-luminous Digitrons enable the digits of the calling or called number to be readily observed

## RELIABILITY AND SERVICE SECURITY

Three principles have been adopted to secure high reliability of the system:

- (a) Component de-rating to minimize catastrophic failure.
- (b) Circuit design based on 'worst case' procedures.
- (c) Extensive use of fault-checking facilities.

Catastrophic failures in electronic components are guarded against by adequate voltage and dissipation de-rating. The component values from which dissipation is calculated are based on life-test results; these values often vary between wider limits than are indicated by initial selection tolerances.

Reliable circuit performance is obtained by basing circuit design on the worst combination of conditions which will be encountered. The worst case is that which arises when the maximum permitted adverse tolerances of component values (including accumulated deviations during the life of the system), circuit loading, power supplies, and temperature occur at the same time. Since these conditions are allowed for in the design, it follows that any one component can deviate from its normal performance by a very much wider margin without in any way affecting operation of the circuit as a whole. Although component de-rating and circuit design can minimize circuit failures, these still remain a significant possibility, and steps must be taken to minimize the effects of such failures. In the case of some types of circuit used in the exchange, several identical pieces of equipment are needed for normal operation, e.g. cross-point switches and registers. It is possible to arrange these circuits in such a way that in the event of one circuit being put out of service the exchange remains fully operational, though perhaps with a reduced grade of service. The greatest number of subscribers which could be put out of service by a single fault in these types of circuit is five: they would be the five subscribers connected to a basic  $5 \times 5$  A-switch which was exhibiting a particular type of fault.

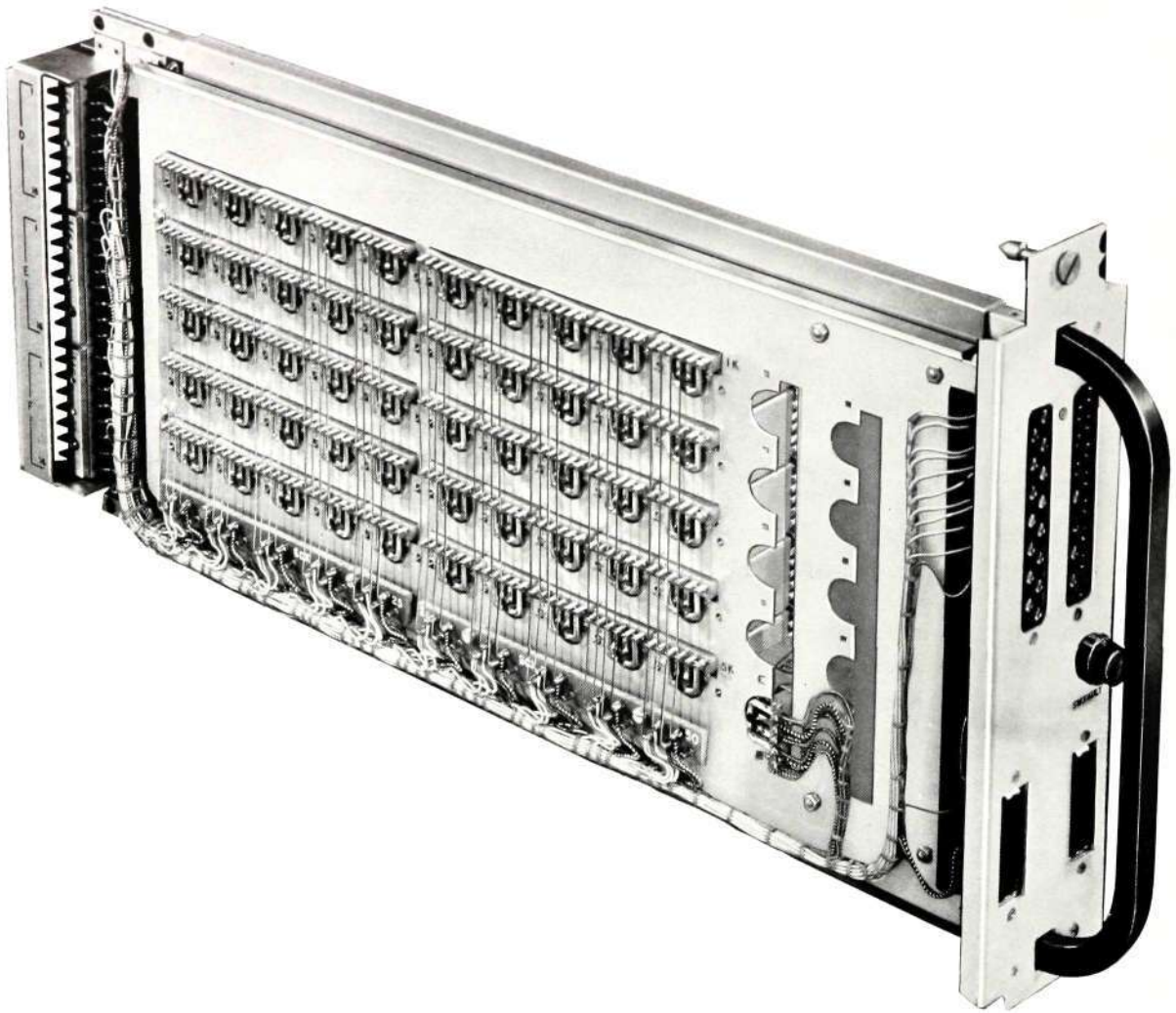

**Figure 5—B switch (5 × 10). Two of these units are used to form a 10 × 10 switch. The single relay near the front panel is the Alarm Relay**

#### PROTECTION AGAINST CROSS-POINT FAILURE

In all the cross-point switches, diodes are used to isolate from each other the several paths through the switch. Short-circuiting of a diode could cause faulty switching, resulting in two calls being connected together, and must therefore be guarded against.

Immediately after each switch-selection process has been completed, a check is made to establish the correct functioning of the switch and its associated diode. If this check indicates a failure, the switch is rendered unavailable to further calls, and an alarm is given. Since subscribers have access to all the B and C-switches, failure of one of these switches does not affect any subscriber directly, but merely reduces the traffic-carrying capacity (grade of service) of the exchange. Failure of an A-switch does directly affect

the subscribers connected to it. However, only the faulty sub-section of the switch (5 × 5) is put out of service, and the number of subscribers thus affected is restricted to five. Failure of a call to be switched to or from these five subscribers could appear as a functional failure of the common equipment. To prevent this, a signal is sent to call control indicating that failure to establish the call is due to the subscriber's circuit and not the common equipment.

The register access switch (which connects a register to a supervisory relay set) is also protected against faulty operation in the same way as the other cross-point switches. To maintain continuity of performance, the register access switch is divided into several separate sections; therefore failure of a diode again only reduces grade of service.

## CHANGEOVER OF COMMON EQUIPMENT

Many of the circuits in the exchange are common to each call passing through the exchange. Failure of one of these circuits would therefore affect the setting-up of all calls, and to obtain high reliability of the system all of the common equipment circuits are duplicated. The two sets of common equipment, designated side A and side B, are brought into service alternately every eight minutes under normal conditions; if a fault occurs in, say, side A, then side B provides service continuously and side A is locked out of service until the fault is cleared.

If due to a fault condition the whole of the common equipment were to be changed over, then one fault in each side, occurring together, would be sufficient to put both sides out of action. Greater reliability is obtained from the duplication of common equipment by dividing the equipment into three sections (termed security sections), each section including those circuits with closely related functions. For instance, section one contains the calling number generator and store, and the store allotter. Service will be maintained in the event of a fault in both side A and side B of the common equipment unless both faults occur in the same section of each side, e.g. section one of side A and section one of side B.

In order to enable each of the three common-equipment sections to be changed over independently of the other two, each has its own changeover control circuit. The three changeover circuits are identical in operation.

## NORMAL CHANGEOVER AND TESTING

The two sides of the common equipment are not used as main and standby equipment, since the effect of long idle periods without frequent testing would tend to reduce the reliability of the standby equipment. Instead, the two sides are in use alternately, and are changed over every eight minutes in response to a pulse from a timing circuit. By this means all the common equipment is checked regularly by being put into service, and the changeover control circuit is itself checked at each changeover. If the common equipment is in use when the changeover pulse is received, changeover is delayed until the equipment is free.

During quiet periods, an exchange fault could occur which would not be detected until perhaps an hour later when a call was attempted. To ensure that a

fault becomes evident soon after it occurs, test calls are put through the exchange at regular intervals. These test calls are simulated outgoing and incoming calls which are set up alternately at two-minute intervals. Should a test call fail it is repeated immediately, and a second failure results in the changeover of the common equipment. The use of this test call procedure further reduces the risk of subscribers' calls not being successfully completed.

## CHANGEOVER UNDER FAULT CONDITIONS

Faults of a serious nature occurring in one of the common-equipment circuits cause a signal to be sent to the circuit controlling changeover of that section. The duplicate equipment is brought into use and the section containing the faulty equipment is locked out of service until the fault is cleared.

Some of the faults occurring in the exchange may be random ones which occur owing to an unusual combination of circumstances. Since such faults are not likely to recur, and are therefore probably not traceable, no purpose is served by operating the alarm and changeover circuits. It is therefore required to suppress certain of the faults if they occur only once, but to take action if the fault recurs. Call control, and the class-of-service amplifiers contain circuits which 'store' a first fault and cancel it after a period of 30 to 60 seconds. Only if a second similar fault occurs during this period is the alarm condition extended to the change-over control-circuit. A similar circuit is employed in the registers, but in this case the alarm is extended if two *consecutive* calls are faulty, i.e. if no successful call occurs in the intervening period (irrespective of how long this is). The adoption of slightly different criteria of double faulting in the register and call control is required by the different functions of these two circuits. In the register, faults which are going to prove serious are likely to occur on successive calls, i.e. successive operations of the register. In call control, however, because it is called into use briefly each time for one of several different operations, two faulty operations of the same kind may be interspersed with a successful operation of a different kind, so that if the consecutive-fault criterion was employed no alarm would be given. It is therefore necessary to employ a circuit which responds to any two faulty calls occurring within a certain period (30 to 60 seconds).

To obtain the maximum reliability from a duplicated system, the changeover control equipment must itself be protected against faults. The changeover control

equipment for the Pentex exchange has been designed on the 'fail-safe' principle, and ensures the continuation of satisfactory service even if normal changeover fails to take place, or if fuse failure interrupts the power supply to any piece of common equipment or the changeover control circuits, whether they are in use at the time or not.

#### REFLECTED FAULTS

Because the setting-up of a call employs most of the circuits of the common equipment either simultaneously or in quick succession, a fault originating in one piece of equipment may become apparent (and therefore appear to originate) in another. Changing over the apparently faulty section will not remove from service the actually faulty circuit, and the fault is therefore likely to recur. If it does, the changeover control circuit now detects that a fault has recurred even after changing over the apparently faulty section of common equipment. As a result it causes the changeover of the remaining two sections of common equipment (and the positive 50-volt power supply, which is also duplicated), so that the faulty equipment will be put out of service no matter in which section of the common equipment it may be.

#### MAINTENANCE FACILITIES

Most of the fault-indicating relays lock when operated. Accessible test points are provided on the front of the equipment to allow these relays to be reset by the application of an earth potential. Control via other test points enables the common equipment either to be changed over manually, or to be prevented from changing over in response to any signal.

### TRUNKING

Subscribers are connected, via their line circuits to an A-switch, outgoing (O/G) supervisory relay sets to C-switches, and incoming junction (I/C) relay sets to D-switches. Own-exchange (O/E) supervisory relay sets combine most of the functions of outgoing and incoming relay sets and are connected between C and D-switches. The purpose of the D-switch is to enable terminating calls (incoming or own-exchange) to have a choice of C-switch and therefore a greater probability of finding a free path to the called subscriber.

A typical combination of switches and supervisory relay sets is shown in Figure 6. The trunking between them is designed to provide as many alternative paths as possible between subscribers and supervisory relay sets. In the typical case illustrated in Figure 6, 125 subscribers can be connected to the

first A-switch; each of these subscribers has access to the five B-switches, and through them to the five C-switches. Each subscriber therefore has access to each supervisory relay set.

If the average calling rate of the subscribers was lower, more could be connected to the A-switch. For instance, if the calling rate was halved, 250 subscribers could be connected to an A-switch; this would then contain 50 of the  $5 \times 5$  basic switches grouped in a  $5 \times 10$  array. Conversely, if the average calling rate was higher, fewer subscribers would be connected, and each A-switch would be smaller.

#### Growth FIRST STAGE

For economy in exchange installation it is necessary to provide only that equipment which is required either immediately or in the near future. This in turn demands that when growth takes place it does so with the minimum of disturbance to the existing equipment. A smooth growth pattern is a feature of the Pentex exchange, and is illustrated in the trunking diagram (Figure 6). The initial installation (black lines) caters for up to 125 subscribers generating total traffic of 9 erlangs, and provides a grade of service of 0.02. This means that during the exchange's busiest hour there will be on average nine calls in progress, and the probability of congestion occurring is 0.02. The grade of service of 0.02 is made up of two parts; for 1 per cent of the exchange's busiest hour a subscriber is denied access to A-B trunks because the five available to him are already engaged, and for a further 1 per cent of this hour he is denied access to a suitable supervisory relay set because all are engaged. The 2 per cent time period will be spread over the busy hour in short intervals. Any call attempts made in these intervals will be 'lost calls', i.e. will fail to mature because all circuits are busy. Since calls originate at a fairly steady rate, 2 per cent of originating calls will be lost, or alternatively, the subscriber has a 98 per cent chance of success on his first attempt.

Each of the 125 subscribers has access to five of the 25 trunks to the five B-switches, and each trunk can be seized by any one of 25 subscribers. The same number of trunks (25) is required between the B and C-switches, thus determining the size of the five B-switches as  $5 \times 5$ . Similarly, five C-switches are required, each  $5 \times 5$ , and the outputs of these are connected to outgoing or own-exchange supervisory relay sets, or to D-switches (to receive terminating calls). Where there are more C-switches than own-exchange relay sets, or outgoing relay sets of a particular

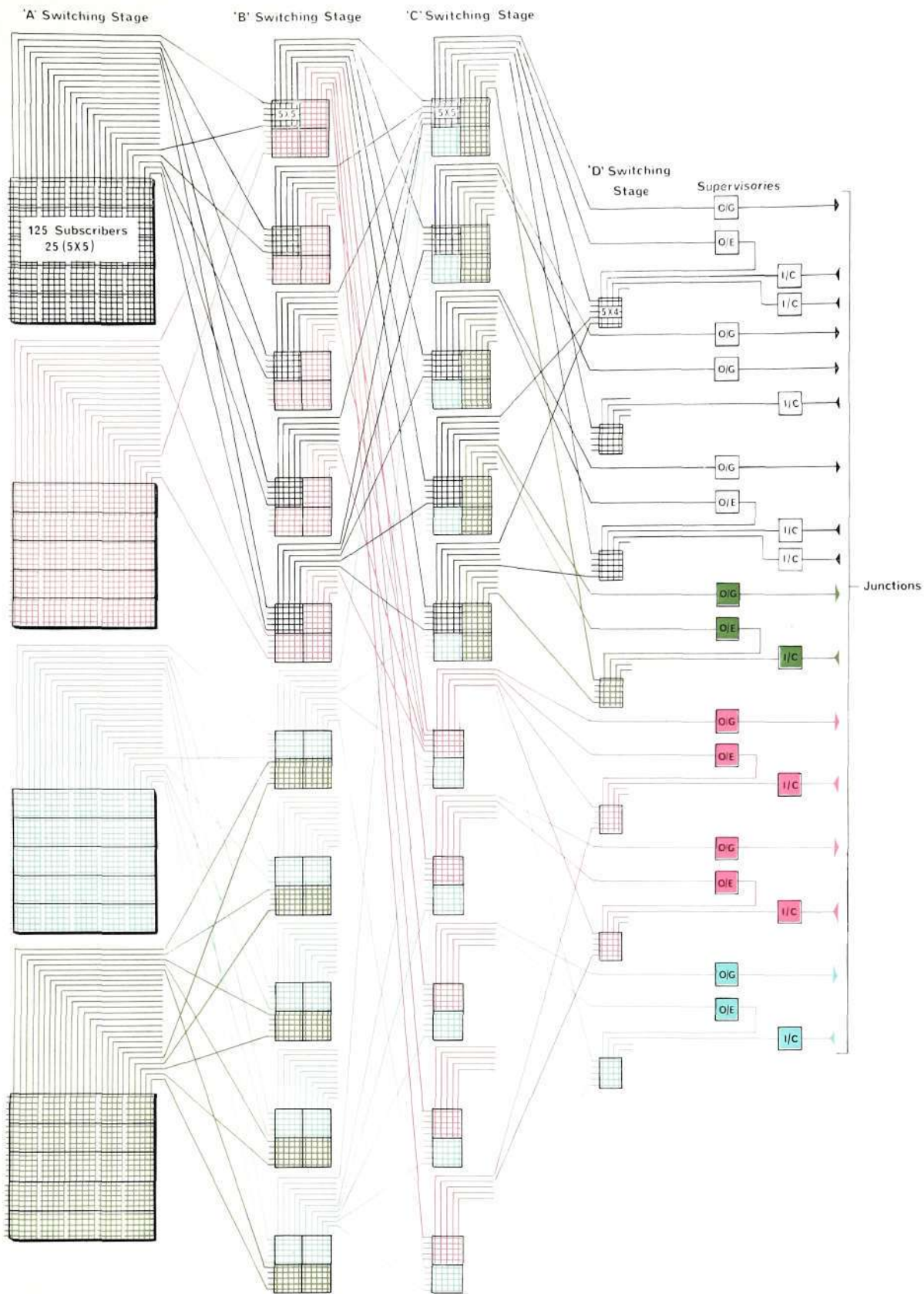

Figure 6—Trunks diagram

type (main exchange or adjacent exchange), it is necessary to make some of the relay sets accessible to two or more C-switches to ensure that any free C-switch can be utilized by each call, no matter to which type of relay set it requires to be connected. Without this commoning it would be possible for a call to fail to be switched, even though a free A-C link existed, because the particular C-switch was not accessible to the required group of supervisory relay sets.

### SECOND STAGE

One basic  $5 \times 5$  switch and five subscriber's line circuits are mounted together on a plug-in panel. This means that the A-switch can be built up in multiples of five subscribers until the limit (125 in the case illustrated) is reached. Beyond this number the

build-up of a second A-switch is started, and the system is developed as indicated in red on the trunking diagram. Since the introduction of a second A-switch increases the number of A-B trunks from 25 to 50, the number of B-C trunks must also be raised to 50 to avoid congestion. Therefore both the inputs and the outputs of the five B-switches must be doubled, converting the switches from  $5 \times 5$  to  $10 \times 10$ . To accommodate the doubling of outputs from the B-switches the number of C-switches is increased from five to ten, thereby accommodating two extra D-switches and six extra supervisory relay sets. If the outlets of two or more C-switches had been commoned as described earlier, the first new connections of relay sets would be made to C-switch outlets which were made available by breaking the commoning links; the remainder of the new relay sets would be connected to outlets of the five new C-switches.

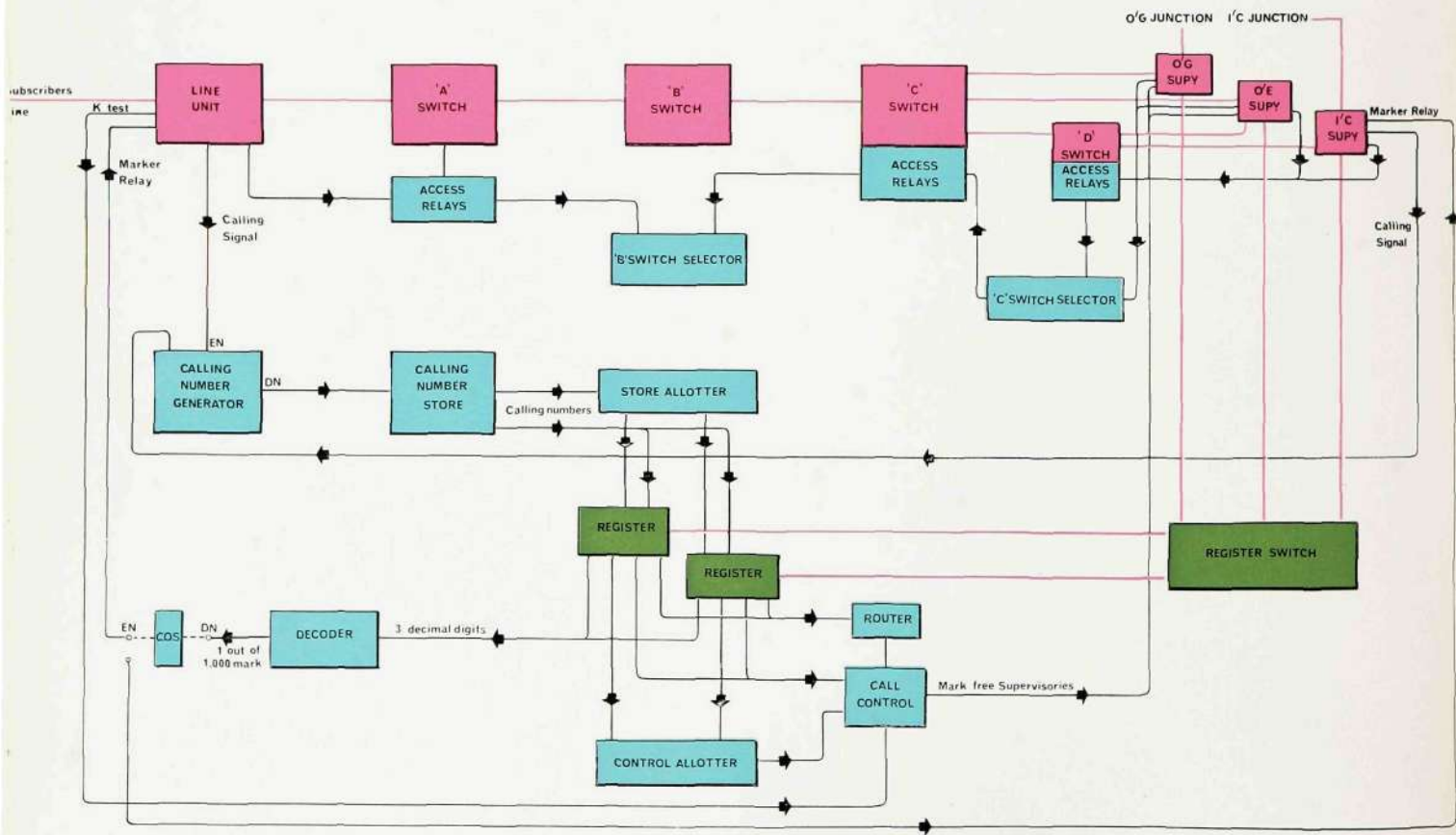

Figure 7—Control diagram

### THIRD, FOURTH AND LATER STAGES

Growth beyond 250 subscribers is shown in blue on the diagram, and from 375 to 500 is shown in green. In each case the extension is carried out by the addition of relay sets, basic switches, and subscribers' line units, and the only disturbance of existing wiring is the possible breaking of C-switch commoning links.

Further growth beyond the limit of 500 subscribers shown in the diagram takes place by adding more switches and supervisory relay sets, and can continue until the economic limit of 150 erlangs is reached.

### CONTROL

The exchange equipment has two main functions: providing a speech path between a subscriber and the supervisory equipment, and the selection and setting-up of this speech path. The block diagram (Figure 7) shows the main units of equipment used in the exchange. The units coloured red carry the speech signals, and are the same units as those shown in the trunking diagram already referred to (Figure 6). The units shown in blue control the call while it is being set up, and are in use for only very brief periods (milliseconds). They are common equipment (i.e. used in turn by each call passing through the exchange), and are therefore duplicated to minimize the risk of exchange failure in the event of a fault. Their circuits are mainly electronic, but employ reed relays for storage purposes.

Intermediate in function between the speech circuits and the control circuits referred to above are the registers and register access switch (coloured green). A register (connected via the register switch) is in use continuously during the setting-up period of the call and, since this period may be half a minute or more, it is necessary to have several registers in order to handle simultaneous calls. These 'simultaneous' calls can, of course, be dealt with sequentially by the common equipment, since it has to spend only a few milliseconds at a time on each call.

Depending on whether the majority of calls originated in an exchange are outgoing or for the caller's own exchange, an outgoing or an own-exchange supervisory relay set is initially connected to the caller. If an own-exchange relay set is first connected and the call is subsequently determined to be an outgoing one, it may be necessary to regenerate the first dialled digit

when the outgoing relay set has been connected. The following description of the setting-up process applies to an exchange where the majority of originated calls are outgoing.

### INITIATING A CALL

When a subscriber lifts his handset, a relay in his line circuit sends a calling pulse to the calling number generator. This sends pulses representing the calling subscriber's directory number (DN) to the calling number store, which immediately instructs the store allotter to allocate a free register to this call. The selected register receives the calling subscriber's directory number in two-out-of-five code form, and stores it on relays. The control allotter connects the register to call control, which instructs the register to pass the subscriber's number to the decoder.

Call control also instructs all free outgoing supervisory relay sets to put out a signal to the C-switch selector, indicating that they are available for selection. A C-switch having a free outgoing supervisory relay set associated with it is chosen. The access relays of the C-switch operate and extend the Test and Mark wires of the chosen C-switch to the B-switch selector. The test wires enable the switch selector to determine which of the B-C trunks are free by examining the potential on the H-wires of the B-C trunk multiples. The mark wires enable the selector to prepare the chosen switching path by marking the appropriate cross-point relay in the chosen C-switch.

Meanwhile, the calling subscriber's digits have been converted by the decoder into a potential on the marker lead to the calling subscriber's line circuit. The marker lead is connected to the decoder via a strapping field which enables a conversion to be made from directory number to equipment number; the strapping field is also used to generate class-of-service information relating to the subscriber. The marker relay in the line circuit operates, and causes the A-switch access relays to operate, extending the test and mark wires of the A-B trunks to the B-switch selector. The B-switch selector now chooses a B-switch which has a free path to the chosen C-switch and to the A-switch (and hence to the subscriber).

One of the free outgoing supervisory relay sets associated with the chosen C-switch is selected by the supervisory relay set selector (not shown on the diagram) and is connected to the register via the register access switch. The supervisory relay set then initiates the switching of the path between it and the

subscriber's line circuit. The K relay in the subscriber's line circuit is operated by call control and is held by an earth via the P-wire from the supervisory relay set.

#### DIALLING

At this stage the subscriber receives dial tone from the register and proceeds to dial. As the initial digits comprising the code of the wanted exchange are transmitted, they are repeated by the supervisory relay set and simultaneously stored in the register in two-out-of-five code form, pending identification by and routing instructions from the router. In some cases the first dialled digit defines the route the call must take, e.g. digit 0 indicates an S.T.D. call to be routed via the main exchange. In other cases the first dialled digit cannot by itself define the required route, and the dialled-in information is not passed to the router until a second digit has been received. If the call is for the main exchange, the register is released and the remaining digits are repeated over the junction by the supervisory relay set.

#### OWN-EXCHANGE CALL

Conversely, if the code digits are identified as those of the subscriber's own exchange, the outgoing supervisory relay set is released and a new path is set up between the caller and an own-exchange supervisory relay set. (The setting-up process is the same as for an outgoing relay set). The remaining dialled digits are stored in the register and are subsequently passed to the decoder upon receipt of a signal from call control. The decoder then operates the marker relay in the line circuit of the called subscriber, prior to the testing of the called subscriber's line by call control.

If the called subscriber is busy, or the number is unobtainable, busy or N.U. tone is received from the register; if the calling subscriber does not clear, then after 20 to 40 seconds the equipment is forcibly released to make it available for other calls.

#### CALLED SUBSCRIBER FREE

If the called subscriber is free, the own-exchange supervisory relay set is instructed by call control to operate access relays in the D-switch in order that the C-switch selector (now performing a slightly different function) can select a D-C trunk associated with the

D-switch to which the chosen supervisory relay set is connected.

A path from the own-exchange supervisory relay set to the called subscriber is set up in a similar way to the path from the calling subscriber to the relay set. Call control and the register are released, and the call is controlled by the own-exchange supervisory relay set, ringing tone being passed to the calling subscriber, and ringing current to the called subscriber. When the called subscriber answers, the own-exchange relay set applies a positive-battery meter pulse to the P-wire, and repeats it at intervals during the call, dependent upon the tariff in force.

At the end of the call, if the calling subscriber releases first, the path through the switches is released immediately; if only the called subscriber releases, the switches are forcibly released after about three minutes and 'plant-busy' tone is returned to the calling subscriber.

#### INCOMING CALLS

When the incoming supervisory relay set is seized by an incoming junction call, the relay set generates a calling signal in the same way as a line circuit does at the start of an originating call. The number which this signal represents is the identifying number of this particular incoming supervisory relay set. The number is stored temporarily in the calling number store and then passed to the store relays of the register allocated to this call. The calling signal also operates a priority circuit in the register, indicating to the call control allotter that this register must have priority, in gaining access to call control, over registers dealing with locally originating calls. This is because the seizure of an incoming junction relay set means that the arrival of dial pulses is imminent, and unless the register is speedily connected to the incoming relay set, some of the incoming dial pulses may be lost. (Delay in connecting the register for an originating call is not so serious—it merely delays the return of dial tone to the calling subscriber.)

Call control instructs the register to pass the number representing the incoming junction relay set to the decoder, which then operates the marker relay in that relay set. This results in connection of the register to the relay set, and enables the dialled digits, received via the incoming junction, to be stored in the register. Subsequent procedure is the same as for a called subscriber receiving an own-exchange call.

**Figure 8—  
Subscribers' Line  
Unit and 5 × 5 'A'  
Switch. The Line  
Unit contains five  
line circuits**

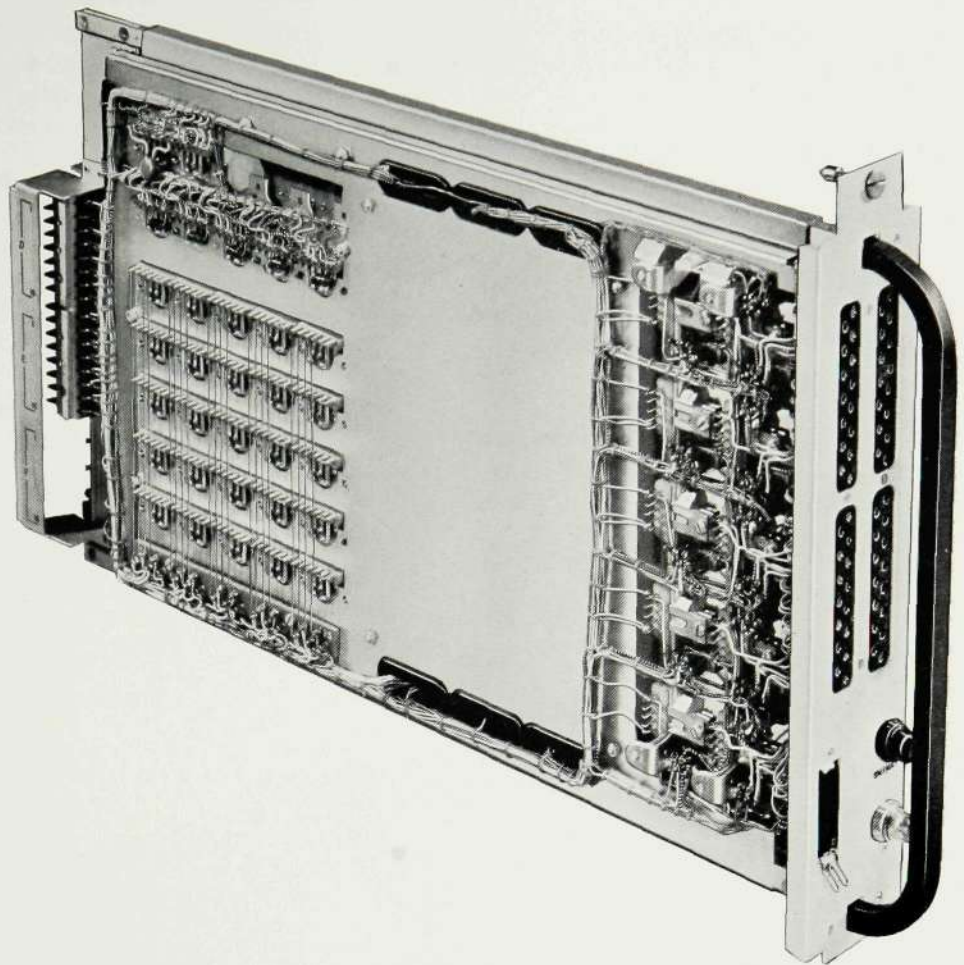

### **CROSS-POINT SWITCHES**

As already briefly mentioned, the basis of the switching network is the cross-point switch, built up from reed relays having four 'make' contacts. For control of the switching path through the electronic exchange, two wires are needed in addition to the pair of wires which carry speech. The private (P) wire is used as in a step-by-step exchange for busying the connection and metering the call. The hold (H) wire is used to switch and hold the cross-point relays which establish the path through the switch.

A cross-point switch therefore consists of a number of four-wire multiples running horizontally (input) and a similar number running vertically (output), with a reed relay and its four contacts connected at each crossing point. In the Pentex exchange the basic switch consists of five horizontal and five vertical multiples with 25 reed relays, and these basic switches are built up to form the A, B, C and register access switches. (The D-switch is a 5 × 4 switch). The A-switch shown in Figure 6 consists of 25 basic

switches arranged in a square (5 × 5); it accommodates 125 subscribers and has 25 trunks to the B-switches, each 25 subscribers sharing five A-B trunks. This particular A-switch caters for 125 subscribers with a calling rate of 0.072 erlang each (total 9). 250 subscribers with a calling rate of 0.036 erlang could share the 25 A-B trunks; the A-switch would then consist of 5 × 10 basic switches.

### **OPERATION**

The principle of the cross-point switch is illustrated in Figure 10, which shows in simplified form the circuit of a 5 × 10 switch. The pairs of resistors marked 19K and 33K form potential dividers between the H-wires and a 50-volt positive battery supply. The junction of each pair of resistors is connected via an access relay contact to a test (T) lead which goes to the switch selector. A free trunk has no potential on its H-wire; therefore the switch selector detects positive potential on the T lead. A trunk which is in use has negative battery potential applied to its H-wire (by the subscriber's line unit), and this will

make the resultant potential on the T lead negative also, thus indicating to the switch selector that the trunk is not available.

When a trunk has been chosen, it is 'marked' in readiness for switching when the complete path through the exchange has been decided. This marking is done by the switch selector, which applies a resistive earth to the mark (M) wire of the chosen trunk. When a complete path through an A, B and C-switch has been marked, switching is initiated by a positive potential which the supervisory relay set applies to the H-wire. The positive potential causes a current to flow through the cross-point relay of the C-switch and via the associated diode to the marking earth. Operation of the cross-point relay joins the horizontal and vertical multiples and extends the positive potential, developed across the marking

resistor, along the H-wire to the B-switch. The marked cross-point relay in the B-switch operates, followed almost immediately by the cross-point relay in the A-switch. The subscriber is thus linked to the supervisory relay set.

When the A-switch cross-point relay operates, it connects the H-wire of the multiple to negative battery in the subscriber's line circuit. Shortly afterwards, the positive potential in the supervisory relay set (which initiated the switching) is replaced by a resistive earth. The cross-point relays are therefore held operated in series between negative battery and earth. The potential at all points along the H-wire is now strongly negative with respect to earth, since the resistance of the cross-point relay coils is much lower than that of the supervisory relay set resistor which terminates the H-wire to an earth.



Figure 9—C Switch, showing three access relays TA, TB, TC, and one alarm relay AL, in addition to the 5 × 10 matrix and its vertical wiring multiples

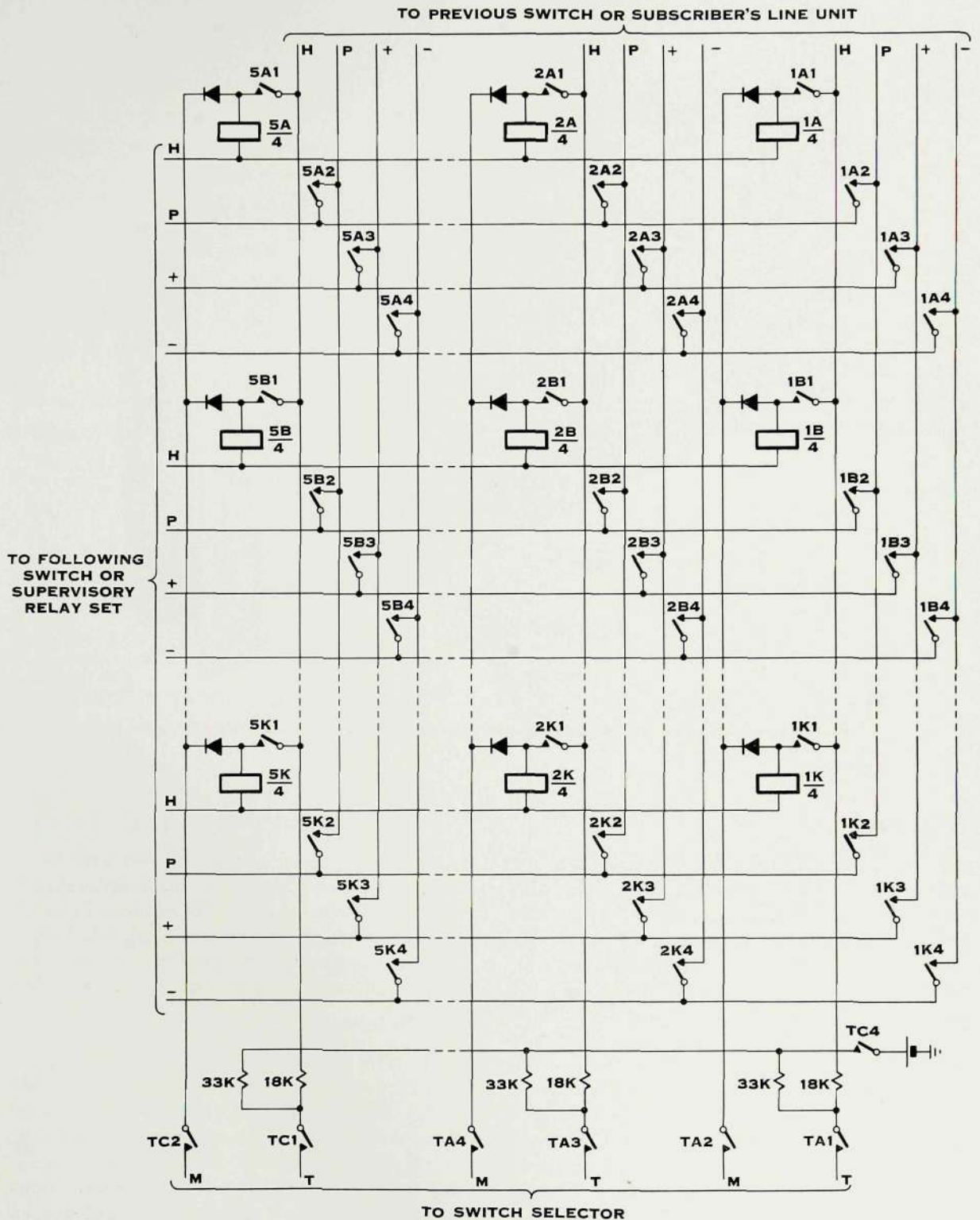

Figure 10—Cross-Point Switch. This diagram shows the wiring multiples consisting of a speech pair (+ and -) and control wires (H and P). The relay contacts enable any vertical and horizontal multiple to be connected together. The test wires (T) are the input leads to the switch selector; the mark wires (M) are the output leads from it

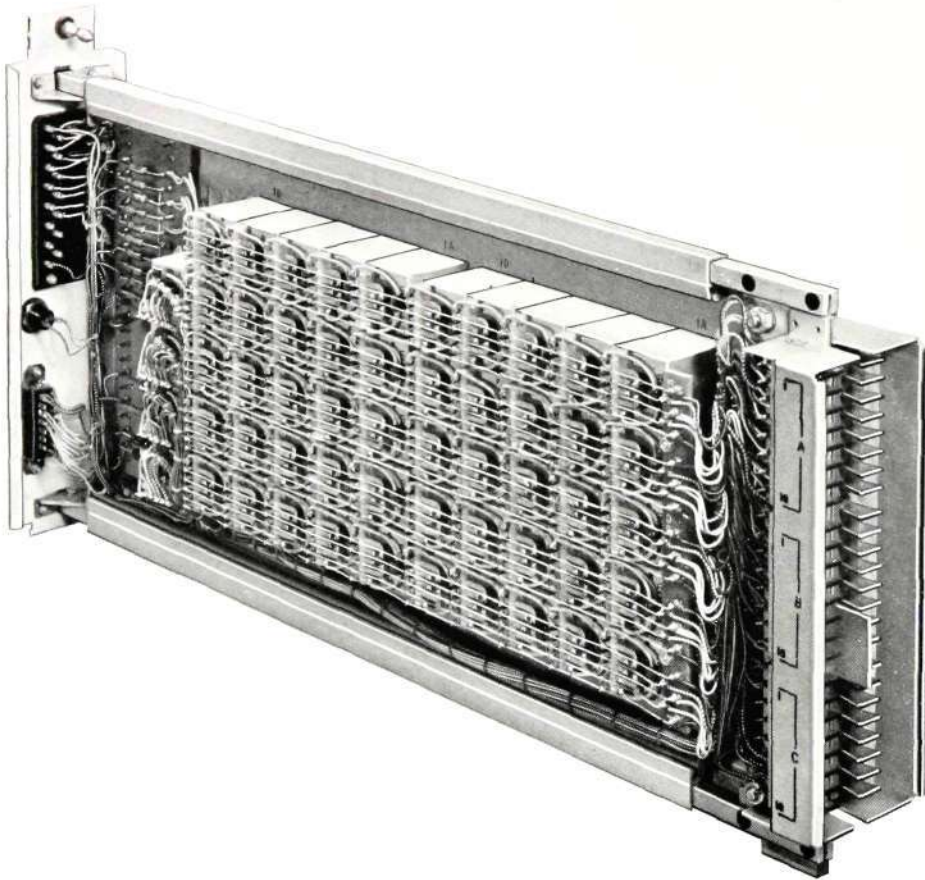

Figure 11—C Switch. Three-quarter rear view showing horizontal wiring multiples

#### ISOLATION OF CIRCUITS

The switches will usually be carrying more than one call at a time (the maximum is five for a  $5 \times 10$  switch), so it is necessary to prevent interaction between the circuits. The purpose of the diode associated with each cross-point relay is to prevent the negative potential on the H-wire of engaged trunks being fed on to the adjacent M-wire, since this would result in unwanted relay operation if more than one call was taking place. For instance, if relay 2A was operated, negative potential would appear on the associated M-wire. If relay 1B was next marked, the subsequent application of the positive operating potential to its H-wire would operate not only relay 1B (to earth) but also relay 2B to negative potential on its M-wire via contact 2A1. This is, of course, the condition which arises if a cross-point switch diode should become short circuit, and to minimize the effects of such a fault, a regular check is made to detect negative polarity of M-wires. This has already been mentioned in the section entitled 'Reliability and Service Security'.

#### REGISTERS (Figure 12)

The dialling operation may take half a minute or more, and during the whole of this period a register is associated with the call. The number of registers required therefore depends on the maximum likely number of calls simultaneously being set up. For instance, about five registers are required for a 500-line exchange.

The main function of the register is the storage of the calling number, and the counting and storage of the dialled digits (i.e. the called number). Signals are received from the calling number temporary store (ferrite cores) in two-out-of-five code and are stored in this form on storage relays in the register. Upon receipt of a signal from call control the register passes the stored number to the decoder which converts the information to a potential on the marker lead of the line circuit of the calling subscriber. This marking enables subsequent switching to take place, linking the subscriber and the supervisory relay set.

Counting of the dialled digits from the subscriber is done by a semiconductor circuit which converts the digital pulses into a two-out-of-five code. The dialled number is stored on relays in the same way as the calling number. The first part of the dialled number consists of code digits (digits which indicate the required routing of the call), and these digits are passed from the register to the router. The router, acting in a similar manner to the decoder, determines the required routing of a call and, if the destination is found to be outside the originating exchange area, the register is released from the call, which is then controlled by the main exchange.

If the destination of the call is within the originating exchange area the calling subscriber is connected to an

own-exchange supervisory relay set (the original path to the outgoing supervisory relay set having been released). The further dialled digits enable the wanted subscriber's line to be identified and rung if free. A similar procedure is adopted for an incoming call; in this case the call comes via an incoming junction supervisory relay set. When the path to the called subscriber is established, the register is released and becomes available for another call.

#### SHARED SERVICE

Another important function of the register is in the setting up of shared-service calls. A signal from the class-of-service circuit to the register, indicating that the calling subscriber is on a shared-service line, causes

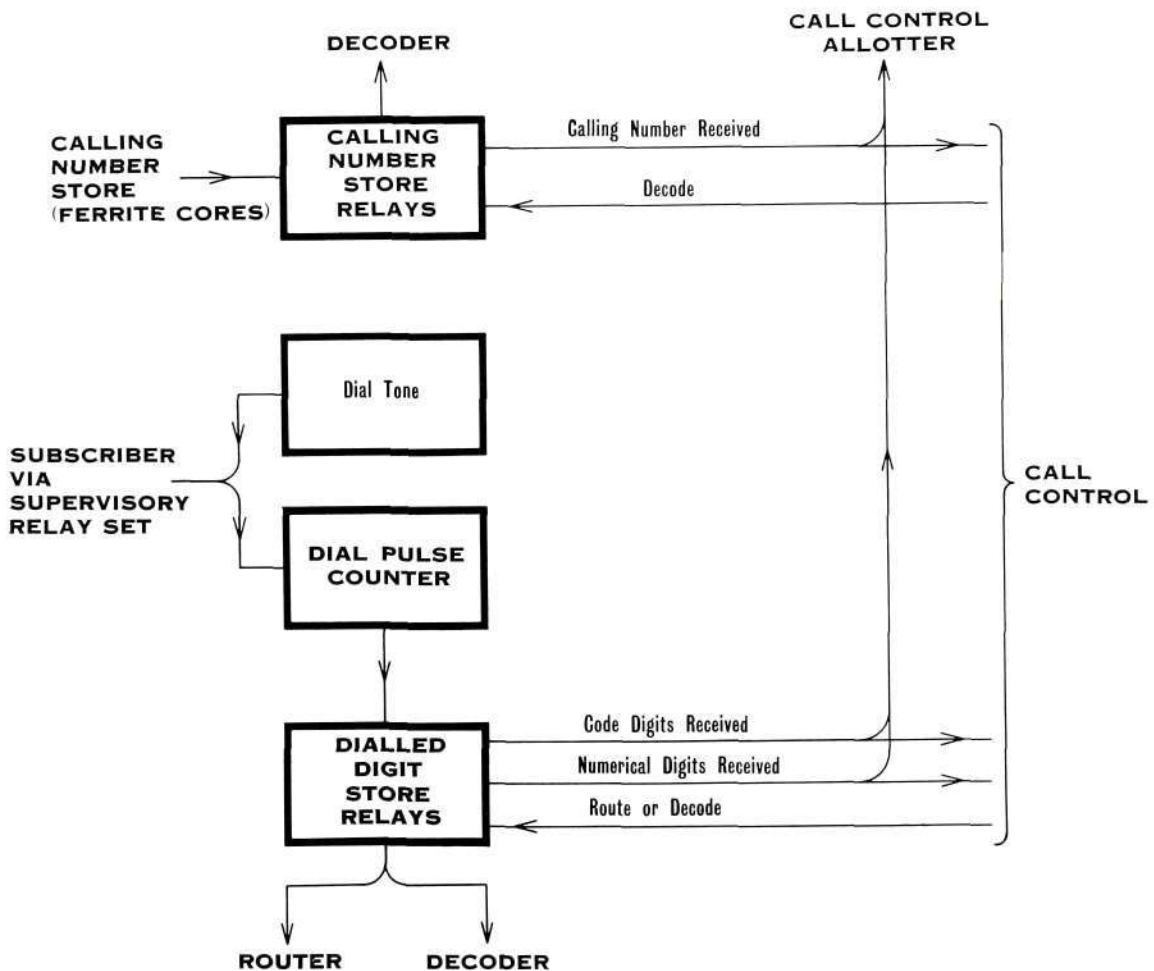

Figure 12—Register block diagram, showing circuits and signals used in the storage of numbers

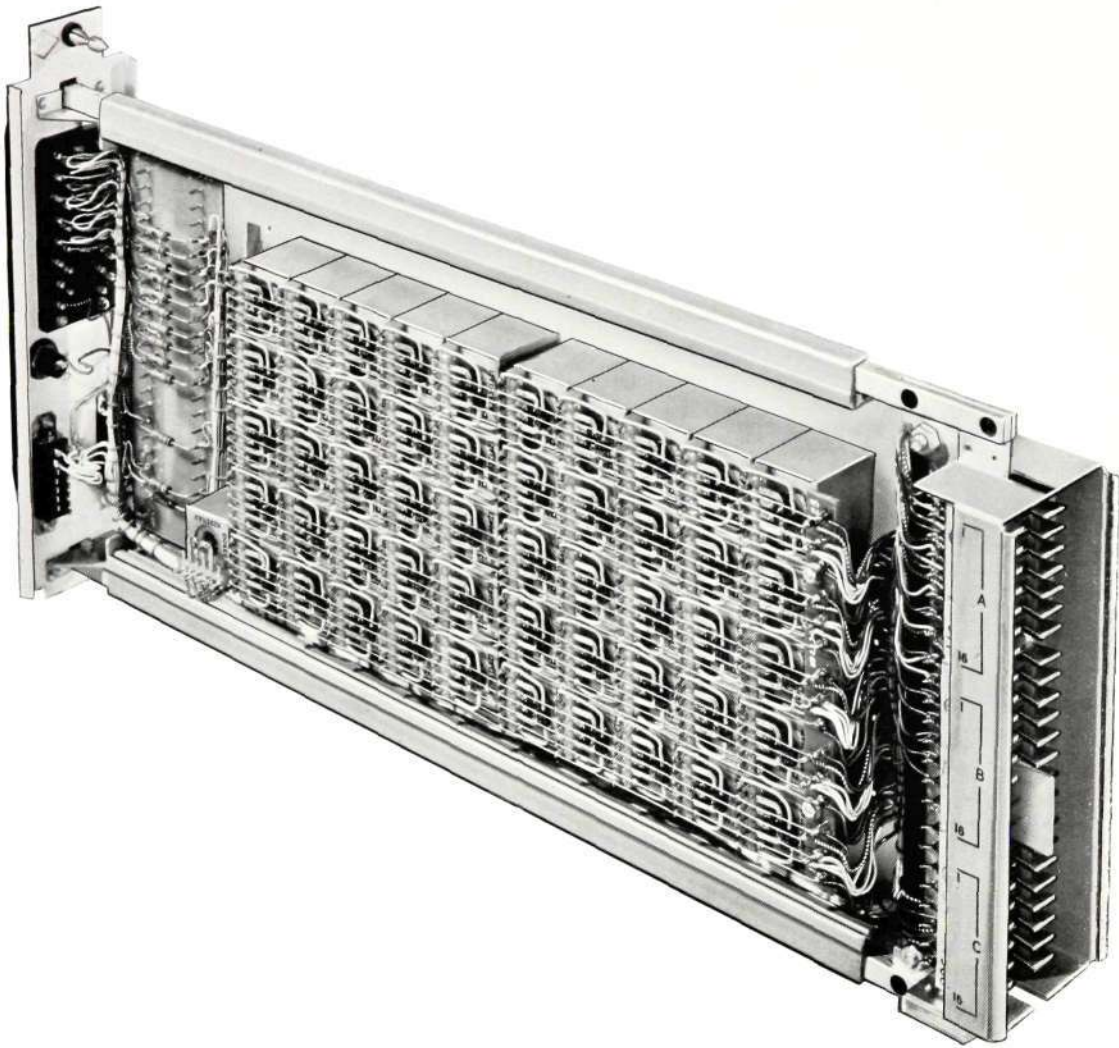

Figure 13—B Switch (5 × 10), showing horizontal wiring multiples

the register to withhold dial tone from the line. When the caller presses the button on the telephone an earth is applied to either the negative or positive wire of the line, depending on whether the caller is an X or a Y party. If an X party, the register connects dial tone to the line, and the call may proceed as for an exclusive line. If the caller is a Y party, his number must be generated (the original number generated was that of the X party). Generating a new calling number means that a new setting-up procedure is initiated, and it will probably utilize a different register, the original one being released. Since party discrimination is now achieved the new register connects dial tone to the subscriber immediately, and dialling can proceed.

#### OTHER FUNCTIONS

Registers are connected to call control at various stages in the setting up of a call to pass or receive information. Among registers awaiting connection to call control, priority is given to those dealing with incoming calls, since the calling subscriber will already have dialled some digits and the next digit is likely to follow after the brief period of an inter-train pause. Failure to connect to call control before the arrival of the next digit would result in the loss of the call, which may be a long-distance trunk call on which considerable setting-up effort has already been expended. An intermediate priority is established by registers which have received the code digits of an originating call; the

lower priority in this case is justified by the fact that, although further digits are likely to follow quickly, the loss of a locally originated call is preferable to the loss of an incoming trunk call.

The registers also control calls to which centralized service observation (C.S.O.) is applied. When the C.S.O. circuit is prepared, the register withholds dial tone from the next call to be originated, until an extra path has been established between the subscriber and the observation equipment.

Barring of trunk or originating calls is also carried out by the register. If a subscriber with a barred-trunks class of service dials '0' or '10', which are trunk call prefixes, the register renders further dialling impossible. The method by which this is done enables an authorized subscriber to remove the barred-trunks condition if desired. If a subscriber barred from originating any call attempts a call, the register is released by call control on receipt of the class-of-service information.

#### TIMING-OUT

Unduly long pauses before or during dialling hold the register for an unnecessarily long time. To limit the length of time that registers can be held, a 'time-out' circuit releases the register if it remains quiescent for between 30 and 60 seconds while seized. The subscriber then receives N.U. tone.

If, after receipt of code digits, there is delay in connecting the register to call control, there is a risk that some of the pulses of the remaining digits may be lost, resulting in an incorrect number being called. To prevent this the register is released after a brief time-out period (about 200 ms).

### SUPERVISORY RELAY SETS

Supervision of each call must be continued after the call has been successfully established, i.e. after the common control equipment and the register have been released to be available for the processing of other calls. A supervisory relay set causes the operation of the selected cross-point switches linking it to the subscriber, and controls the call until it finishes.

There are three main types of supervisory relay set to cater for the three main types of call: outgoing,

incoming, and own-exchange. The outgoing relay sets are used for calls to the main (parent) exchange or to adjacent exchanges. As soon as a subscriber on the Pentex exchange initiates a call, a main-exchange\* relay set is chosen, to be replaced subsequently by an own-exchange or other relay set if the first digits of the dialled number show it to be other than a main-exchange call. Incoming supervisory relay sets (Figures 14 and 15) are permanently connected between incoming junctions and D-switches; the D-switch enables a call on an incoming junction to be routed via any one of the C-switches to the called subscriber.

#### OUTGOING RELAY SET

An outgoing supervisory relay set is permanently connected between a C-switch and a two-wire junction to a distant exchange. It extends a loop via the positive and negative wires to seize the distant equipment, and repeats dialled pulses to that equipment. The dialled pulses are also routed via the supervisory relay set to the register. When a call is established, transmission of speech takes place via a transformer bridge, and local call timing or metering over the junction results in the production of positive battery meter pulses. The relay set also enables an operator to 'hold' calls to the manual board and provides for the repetition of coin-and-fee-checking control signals from the manual board to the C. and F.C. equipment. In the event of the caller not clearing when the distant subscriber has done so, the outgoing supervisory relay set detects, by restoration to normal of the junction wire polarities, that the called subscriber is being held (C.S.H. condition). After a period of between three and six minutes the caller is forcibly released; the called subscriber and the supervisory relay set are thereby freed for further calls.

#### INCOMING RELAY SET

An incoming supervisory relay set, upon seizure by a call on an incoming junction, is connected to a register in order that the incoming dial pulses can be counted and stored. When the number is completed and decoded, call control detects whether the wanted line is free. If it is, the supervisory relay set causes the

\*This assumes that own-exchange calls are in the minority for this exchange. See chapter headed 'Control', p. 15.

path to the called subscriber to be switched and ringing current to be applied. The speech path is completed when the called subscriber answers. If the calling subscriber clears first, the supervisory relay set and switching network are released immediately; if the called subscriber releases first, forced release takes place after between three and six minutes if the caller has not cleared in the meantime, and plant-busy tone is returned to the caller. If dialling pulses are received before a register has been connected to the supervisory relay set, the call is rejected and again plant-busy tone is returned to the caller.

outgoing relay set have established the call as an own-exchange one. (In an exchange where own-exchange calls predominate it is brought into use, instead of an outgoing relay set, as soon as the subscriber lifts his handset.) If no outgoing supervisory relay set is available when an originating call is initiated, an own-exchange relay set is seized, but would be released if the call were subsequently established as an outgoing one. Without this procedure, own-exchange calls would be barred by the absence of a free outgoing supervisory relay set even though the ultimate requirement (for an own-exchange relay set) could be

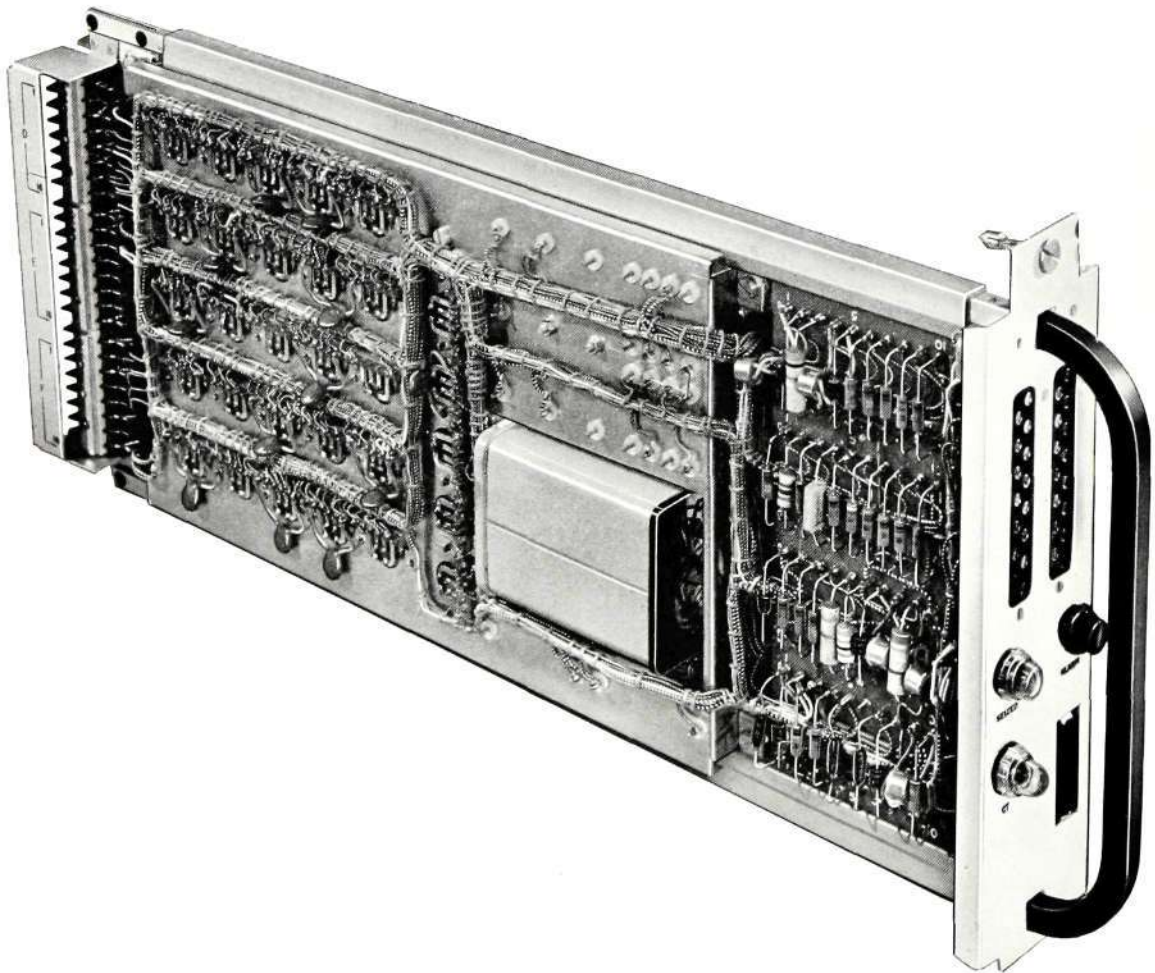

**Figure 14—Incoming Supervisory Relay Set. This view shows how larger components can be accommodated, by through-panel mounting**

#### OWN-EXCHANGE RELAY SET

An own-exchange supervisory relay set is permanently connected between a C and a D-switch. It is brought into use after digits dialled through an

satisfied. The own-exchange supervisory relay set combines many of the functions of the outgoing and incoming relay sets, and its circuit also combines many of their circuit features.

## CALLING NUMBER GENERATION

In an exchange of this kind, as distinct from a step-by-step exchange, it is necessary for the subscriber's line circuit (or the incoming supervisory relay set) to be identifiable as soon as it is seized, to enable connection of the required speech path to it. This is achieved by generating and storing the calling number as soon as the equipment is seized.

16). If the number to be generated is a three-digit one, and is expressed in a two-out-of-five code, the wire must thread six cores; two for each digit. To simplify threading, each wire passes only once through each horizontal row of five cores, therefore six rows of cores are required for the three digits. Since the calling number generator is 'common' equipment (i.e. equipment used by each call in turn) it is duplicated to ensure continuity of service in the event of component

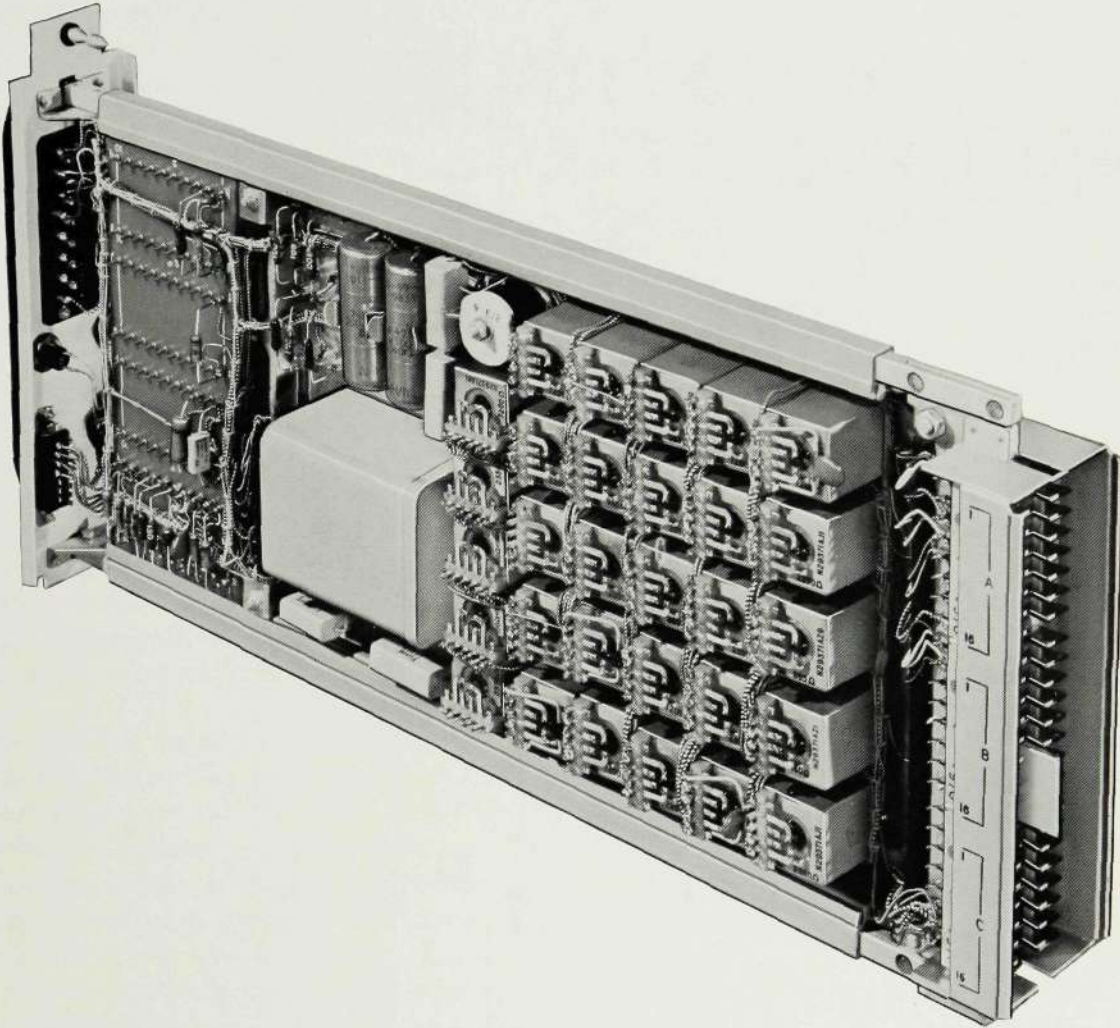

Figure 15—Incoming Supervisory Relay Set. (Three-quarter rear view)

When a subscriber lifts his handset, or an incoming junction supervisory relay set is seized, a current pulse is sent from the subscriber's line circuit or the relay set to the calling number generator. This consists of linear-response metal tape cores, through a number of which the pulse-carrying wire is threaded (see Figure

failure; this requires a total of 12 rows of five cores to represent three digits.

In addition to generating digital information, the calling pulse must also provide control signals for the calling number store and, in the case of incoming

junction calls, a priority signal. These signals are generated by passing the pulse-carrying lead through additional cores.

The cores act as transformers, and the lead threaded through is in effect a one-turn primary winding. Each core has a 100-turn secondary winding and, since the cores are duplicated for ease of threading, the

secondary windings of each related pair are connected in parallel. Each pair of secondary windings is connected to a separate amplifier which, on receipt of a calling pulse, gives out an amplified pulse. This pulse writes the digital information in a temporary store prior to transfer to the longer-term store in a register.

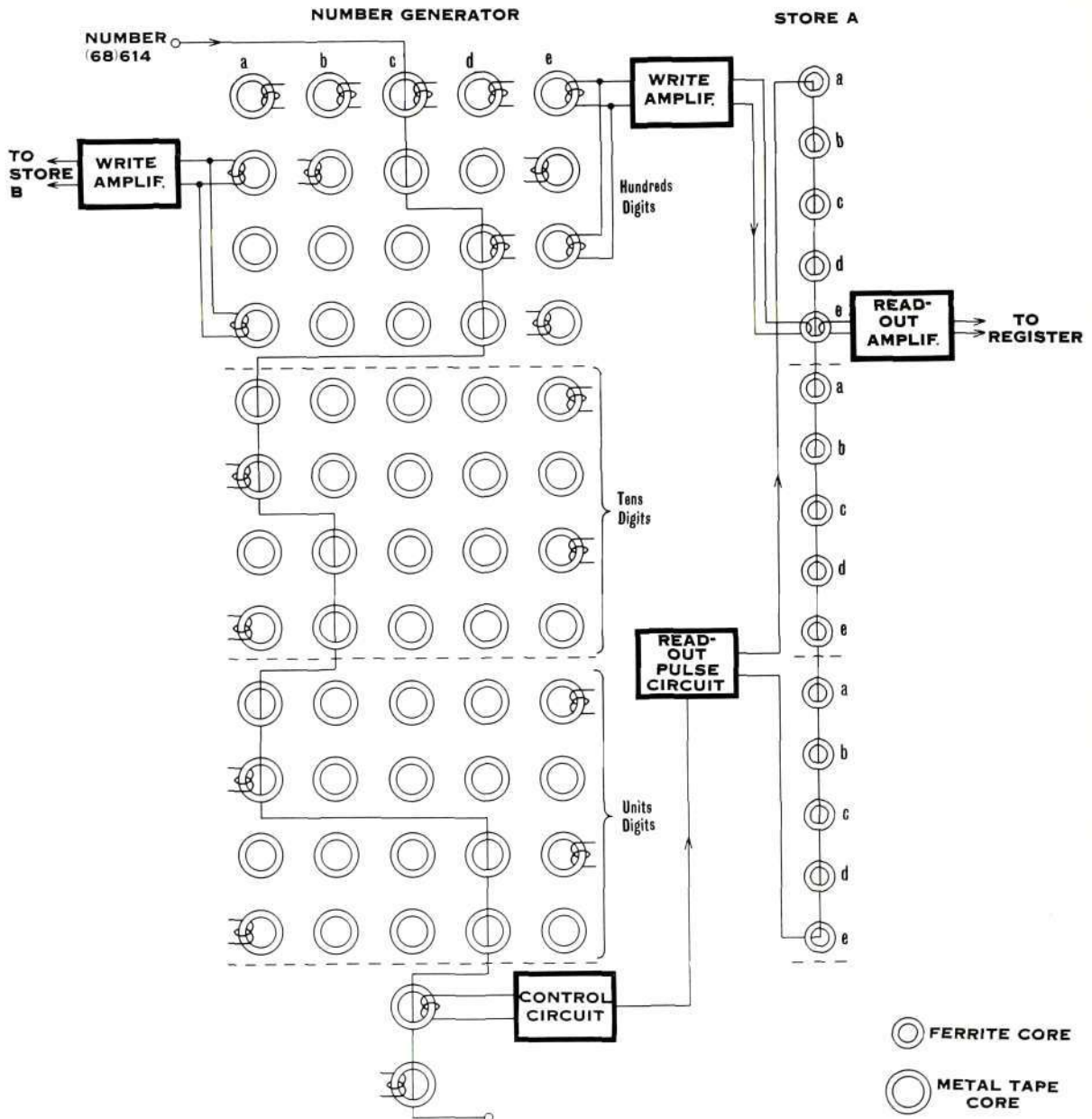

Figure 16—Calling Number Generator and Store. The subscriber's full number is not generated since the first two digits (68) are the exchange code digits common to all subscribers on that exchange

## TEMPORARY STORAGE OF CALLING NUMBER

A ferrite-core store is used to store the calling number until a register is connected to take over the number-storage function. The temporary store consists of a column of two-millimetre ferrite cores. Because of its 'square-loop' characteristic the ferrite material normally exists in one of two magnetized states; the state can be changed by a pulse of current along a wire threaded through the ferrite core.

The output from the amplifier whose input is connected to a pair of metal-tape cores is termed a 'write' pulse because it 'writes' an element of the calling number into the store, i.e. it changes the magnetic state of the core through which the pulse-carrying wire is threaded.

## READ-OUT FROM STORE

At the same time as the calling number is written into the temporary store, the operation of 'reading-out' the number to the register's store is initiated. A 'read-out' pulse of opposite polarity to the 'write' pulse is sent along a wire threading all the ferrite cores in the column. Other wires, each threading only one core, are connected to 'read-out' amplifiers. The read-out pulse causes a change of magnetic state only in those cores which were affected by the write pulse, i.e. those cores which are storing numbers. The change of magnetization of these cores produces pulses which are fed to the associated read-out amplifiers.

The circuit of the read-out amplifier includes a silicon controlled rectifier (S.C.R.) which strikes in response to the input pulse and remains in this state until the stored information is transferred to a register. The ferrite-core store information is erased by the reading-out process, and the S.C.R.'s therefore act as an intermediate store until the register is connected. The rapid clearance of the core store after receiving a number, ensures that it can handle two calls arriving in quick succession; if a second call arrives more than half a millisecond after the first call, both numbers will be satisfactorily generated and stored.

## CALL CONTROL

The operation of all the circuits in the electronic exchange is co-ordinated by call control. Information

is passed to call control at various stages in the setting-up procedure of a call, and signals are sent from call control to initiate the operation of associated circuits. For instance, when the register has received into its store a calling subscriber's number, a signal from call control causes the register to pass the calling subscriber's number to the decoder. Also, call control receives class-of-service information relating to a call and controls the call accordingly.

## K-Test

Another important function of call control is to test the condition of a subscriber's line when the subscriber is making or receiving a call. This test determines whether a subscriber originating a call has been connected to a supervisory relay set; it also determines whether a subscriber to whom a terminating call is being routed is engaged or free. The test consists of examining the potential appearing on the terminal of the line-circuit K relay remote from negative battery, and is termed the K-test.

The subscriber's line is normally in one of three conditions, each of which causes a characteristic potential to be applied to the K-test lead.

### (a) SUBSCRIBER FREE

If the subscriber's line is free, a potential is derived from negative battery via the 1500-ohm winding of the K relay, in parallel with an 820-ohm resistor which is connected when the subscriber's L relay is not operated (i.e. the line is not looped). The combined resistance is about 500 ohms.

### (b) SUBSCRIBER LOOPING LINE

If the subscriber has looped the line in order to originate a call, the L relay will have operated, disconnecting the 820-ohm resistor and leaving the negative battery potential applied to the K-test lead through the 1500-ohm K-relay winding only. This condition occurs also if the subscriber has been 'parked' due to a permanent line-loop or failure to clear from a previous call, and in this case renders the line unable to receive a terminating call.

(c) SUBSCRIBER ENGAGED

If the subscriber is already engaged upon a call, the K relay has operated and is held to an earth on the P-wire. The K-test wire is therefore at earth potential.

For an originating call, the K-test circuit distinguishes between negative and earth potential on the K-test lead. If the potential is negative, the circuit condition is satisfactory and the calling subscriber can be switched to a supervisory relay set. If the K-test lead is at earth potential, the circuit is faulty and switching will not take place.

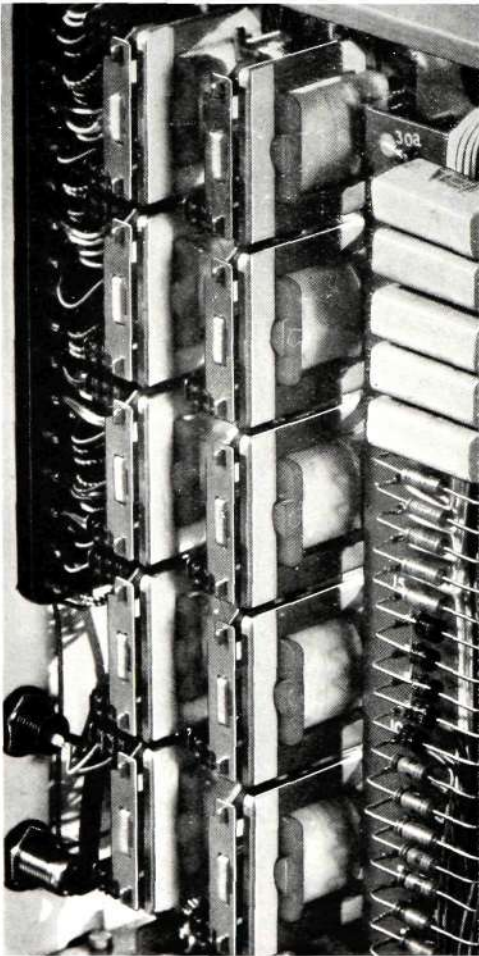

Figure 17—The front end of the Subscribers' Line Unit, showing two Strip Relays (Type 12). These relays, developed by E.T.L., consist of five independent relays on a common yoke, providing one L and one K relay for each of the five Subscribers' Line Circuits

For a terminating call, the K-test circuit distinguishes between the 500-ohm and 1500-ohm resistive battery potentials. If the K-test lead is highly negative (500-ohm negative battery), the line is free and a call can be switched to it. If the K-test lead is less negative than this (i.e. 1500-ohm negative battery or earth) the line is either parked or is already engaged. In either case it is unavailable and the call will not be switched through to it.

An important feature of this method of controlling the switching to a subscriber's line is that the normal K-test function can be simply modified to allow switching to take place under any condition of the subscriber's line. This is the requirement imposed by test-desk calls and trunk-offering calls from an operator, and it can be satisfied in the Pentex exchange without the use of the separate switching network required in a step-by-step exchange.

## SELECTORS

In order to set up a call, it is necessary to select one of several paths by which the subscriber can be connected to available supervisory relay sets and to a register. The path is selected in several stages, and only when all the stages have been selected and marked is the path switched. The selection process is similar for both outgoing and incoming calls. The sequence of selection for outgoing calls is: Register, C-switch, B-switch and Supervisory Relay Set.

### THE SELECTION PROCESS FOR AN OUTGOING CALL

Selection of a register is initiated by the calling number store when it receives a number, and selection of a C-switch is initiated by call control.

Call control is first connected to the register when the register has received the calling subscriber's number from the calling number store. Call control then causes free supervisory relay sets to put out signals to the C-switch selector and the supervisory relay set selector, indicating that they are available for selection. The C-switch selector chooses a C-switch which has at least one free outgoing supervisory relay set associated with it, and extends to the B-switch selector the test and mark wires of the B-C trunks from this C-switch.

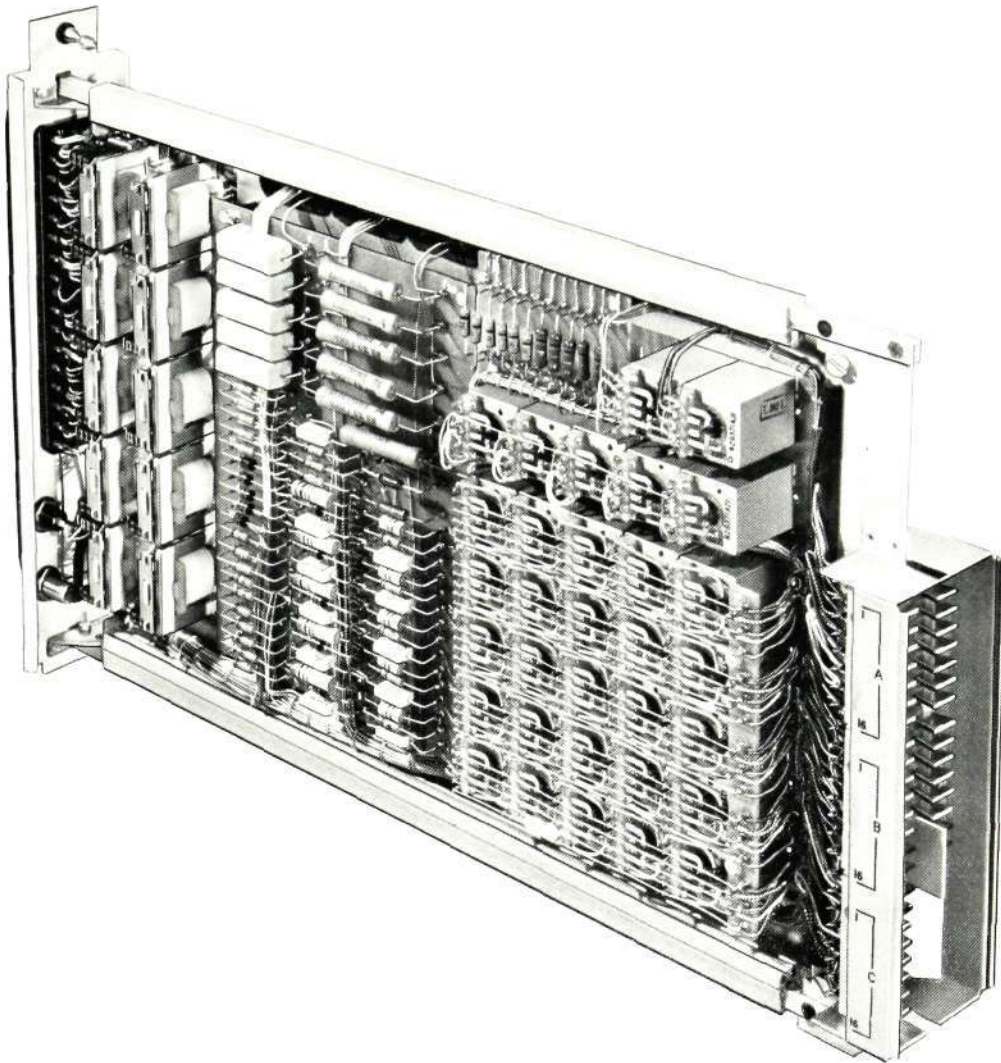

Figure 18—Subscribers' Line Unit and 5 × 5 'A' Switch. (Three-quarter rear view)

The B-switch selector also has extended to it the T- and M- wires of the A-B trunks and can therefore select a B-switch with both a free A-B trunk and a free B-C trunk. When the path from the subscriber via the A and B-switches to the C-switch has been marked, one of the available supervisory relay sets is selected, and this relay set initiates the switching of the path to the subscriber.

#### SECOND SELECTION

It is possible that a complete path is not available between the chosen C-switch and the calling subscriber's line circuit because of the lack of a free B-C trunk or a free A-B trunk, or both. If there are no

free B-C trunks, this information is signalled to the C-switch selector, which chooses another C-switch, and a second attempt is made to find a complete path to the subscriber. The attempts continue until all the C-switches have been tried and, if then no path has been found, an indication of the ' busy ' condition is given.

#### ALL A-B LINKS BUSY

If the inability to complete a path to the subscriber is due to the fact that there are no links available between the B-switches and the subscriber's A-switch, there is no point in proceeding beyond the first attempt. One of the functions of the B-switch selector, therefore,

is to detect specifically the state of the A-B links and inform call control if none is available. Call control then prevents any further attempts at selecting a path.

#### PRINCIPLE OF SELECTOR OPERATION

The selectors use semi-conductor logic circuits, and all operate on the same principle, although they differ in detail because of their slightly different functions. The input leads to the selector are the 'test' wires of the switches (or registers) about to be examined; the output leads are their 'mark' wires.

In order to spread the traffic evenly over all the switches, they are chosen in cyclic order; this requires a 'memory' in the selector to identify the previous selection. The choice is then dictated by the following consideration: the switch to be chosen is the next free one in cyclic order to that last selected. At each of the inputs of the selector is an 'and' gate which operates only if the following three conditions are fulfilled:

- (a) There is no 'busy' signal on the test wire.
- (b) There is no inhibiting signal from the input gates earlier in the cyclic order.
- (c) There is no inhibiting signal from the last-selection store (memory).

When the gate operates it causes marking of the chosen switch, and records the new selection in the last-selection store.

Adoption of the principle of cyclic selection must not be allowed to bar from selection, because it does not occur in cyclic order, an outlet which is the only one available. The selector is therefore designed so that, before an 'all-circuits-busy' signal is given, the store is cleared to give any free circuit the opportunity of being seized.

#### TEMPORARY STORE

A C-switch is chosen in order to test the availability of a path from it to the subscriber. The choice is therefore a tentative one, and several C-switches may be 'chosen' before one is found having a free link between the A and C-switches. Examination of the

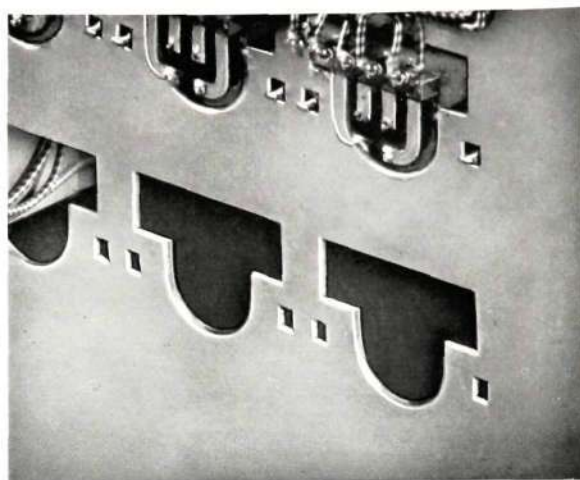

**Figure 19—Part of the Register, showing holes blanked-out of the mounting plate. Fixing the reed relays in this way enables connections to be made from each side of the mounting plate**

A-C links offered by the particular C-switch is done by the B-switch selector (the A-C links from each C-switch utilize all the B-switches), and the C-switch selector chooses another C-switch, upon receipt of a signal from the B-switch selector indicating that no through path is available from the C-switch or switches already offered. It is therefore necessary for the C-switch selector to record each unsuccessful choice for the brief period (milliseconds) that the selection process is taking place. This record is kept by the temporary store, whose function is similar to that of the last-selection store in ensuring the correct cyclic order of selection. The temporary store has one relay associated with each of the C-switches; at each unsuccessful attempt at choosing a C-switch, the associated temporary-store relay operates and causes the next selection to be made. Operation of the temporary store relays enables each C-switch selection to be cancelled before the next one is made. This prevents the risk of associating the 'busy' signal from the B-switch selector with the new and unexamined C-switch.

Only after the operation of all the temporary-store relays is the signal sent to call control indicating that no path is available between a subscriber and a supervisory relay set.

## EQUIPMENT PRACTICE

The various circuits of the electronic exchange (switches, selectors, registers, etc.) are mounted on jack-in panels which form part of a highly versatile system termed the Ericsson DSU System. This has been designed to provide a standardized method of mounting equipment racks and panels, and is at the same time sufficiently flexible to cater for individual circuits of widely differing size and complexity.

DSU is a modular system consisting of standard jack-in units arranged in rows within a main framework which is normally 8' 6" or 10' 6" (2.6 m or 3.2 m) high by 3' 0" (92 cm) wide by 1' 10" (56 cm) deep. Frameworks of other heights can be provided.

The basic jack-in unit is 9" (23 cm) high by  $2\frac{1}{2}$ " (6.4 cm) wide by 1' 6" (46 cm) deep. A typical basic unit houses five subscriber's line circuits and their associated  $5 \times 5$  A-switch, or two  $5 \times 5$  switches. Multiple-width units are provided to accommodate larger pieces of equipment. For instance, call control occupies the space of three basic units, and a register occupies five spaces. The exchange is built up by assembling the requisite number and combination of units into 8' 6" or 10' 6" cabinets.

The 8' 6" (2.6 m) rack accommodates nine rows each containing twelve  $2\frac{1}{2}$ " (6.4 cm) width units. The units slide into the main framework on runners and are locked in position by a single fastener. Electrical



Figure 20—Front Panel of Incoming Supervisory Relay Set, showing (from top to bottom) monitoring sockets, signal lamps, call-trace neon lamp, and test jack

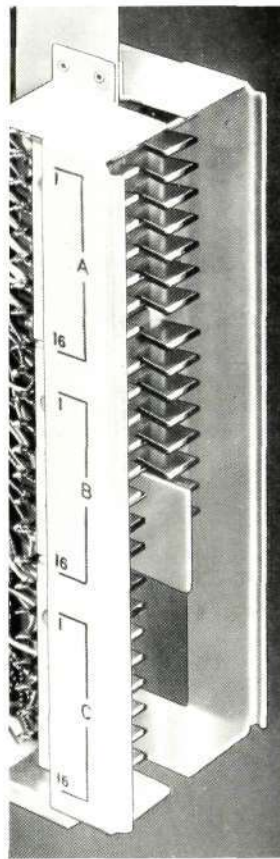

Figure 21—Jack-plug at the rear of a jack-in panel. This view shows the metal tongue which engages with a mortise on the jack-plate

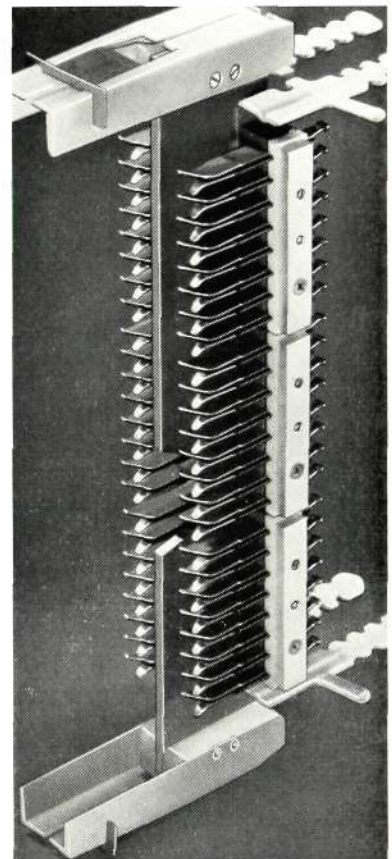
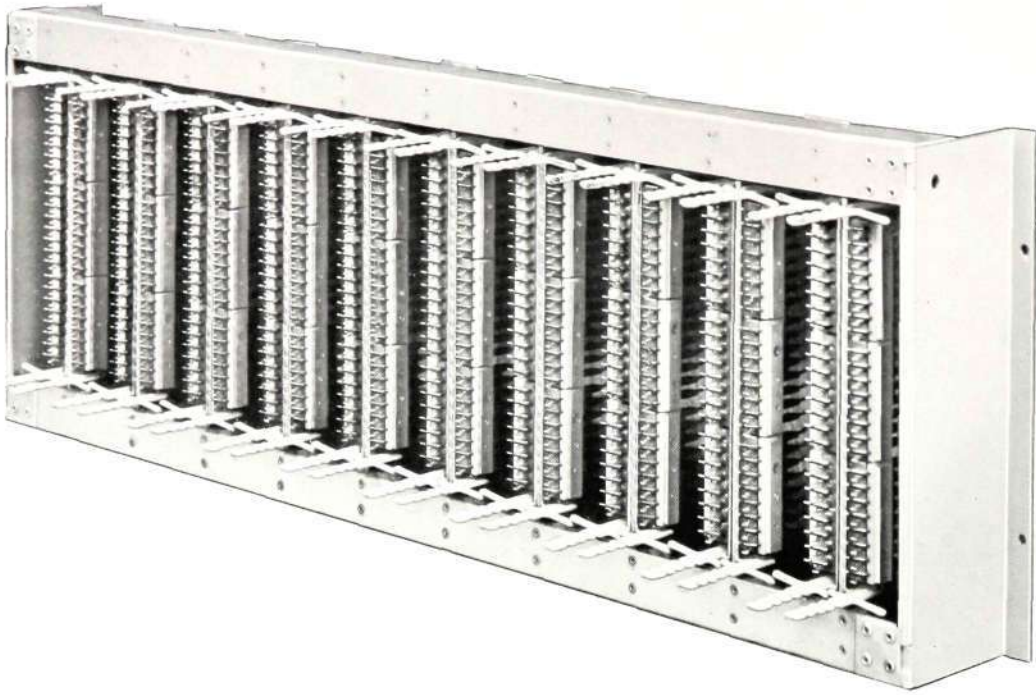

Figure 22—The Jack Assembly of the DSU Equipment. The tapered mortise in the vertical plate facilitates accurate location of plug and jack



**Figure 23—A removable shelf unit of the DSU Equipment. (Rear view showing wiring tags.)  
This unit can be wired before assembly into the rack if desired**

connection made is by means of a plug mounted at the rear of each unit. The plug can have up to 96 pins, in multiples of 16. When the unit is pushed fully home and locked, the plug engages with a mating jack on the main framework. The jack contact surfaces are palladium-plated to provide good electrical contact.

With this mode of construction, access to individual components can be gained only by withdrawing the unit from the framework, thereby disconnecting it. To enable potentials and waveforms to be checked while the unit is *in situ* and functioning, strategic points of the circuit are extended to monitoring sockets mounted on the front panel (see Figure 20). Up to 60 sockets can be provided.

The jack-in units use palladium-plated plugs and jacks of conventional form employing high contact-forces (see Figures 21 and 22). The palladium is applied by a patented plating process, as a result of which a hard, crack-free surface coating is produced. This process is approved by the Royal Radar Establishment for British Services' equipment plugs; the very smooth surface and low coefficient of friction give low

withdrawal forces in spite of the large number of contacts and the high individual contact-force. The physical design of the jack-in units is such that electronic component boards either printed or conventionally wired, reed or other relays, telephone components of other kinds, power units, and almost every kind of equipment likely to be required can be mounted in almost any combination.

#### MAIN FEATURES

The DSU system has a number of salient features:

- (a) Location of the plug and jack for each unit is controlled by a tongue on the plug plate and a mating mortise on the jack plate (see Figures 21 and 22). This ensures accurate positioning of the plug relative to the jack, since it is not dependent on accumulated tolerances in the cabinet assembly. Precise positioning enables the specified contact forces to be accurately maintained.
- (b) Each unit is held in place by a single fastener, the stud of which is mounted on the unit front panel.

- (c) A colour-coding system is used, thus avoiding the difficulty of mounting labels on the rather narrow front panels. With three coloured dots and a range of ten colours, 999 different codings are possible. The colour coding on the panel overlaps, but only partially obscures, the colour coding on the horizontal support; incorrect positioning of panels is therefore readily detected by the contrast of colours.
- (d) The cable supports are secured to each jack assembly individually, so that if the jack moves when a unit is inserted the cable moves with it and there is no strain on the soldered joints.
- (e) Multiple units are simply constructed by securing at the front and rear a number of single frame units, separated by some multiple of the distance between adjacent guides in the cabinet. Since the individual jacks 'float' on their shelf mounting, the relative positioning of the several plugs of a multiple unit does not demand accurate control.
- (f) The length of the contacts in a plug can be varied so that certain contacts will always be 'made' first and 'broken' last on jacking the panel in and out. This is often desirable when power supplies are connected through a plug and socket.
- (g) Shelf assemblies may be wired on the bench and then transferred to racks. This makes wiring easier, and allows racks to be shipped in dismantled form; it also allows them to be erected before the delivery to site of the fully-wired apparatus.
- (h) Extensions to partially equipped racks can readily be made by adding individual pre-wired shelves (see Figure 23). The DSU pre-wired shelf is designed for insertion between the main rack uprights from the *front* of the equipment, thus enabling the additions to be made without disturbing any rack wiring which may be present across the back of the empty shelf space.

## REED RELAYS

For satisfactory transmission of speech through an exchange, the resistance of the speech path must be low, so must unwanted coupling between unconnected circuits. These requirements are best satisfied by mechanically operated metallic contacts (relays), although the reliability and operational life of conventional relays is not as high as may be expected from electronic switching elements.

A satisfactory compromise is achieved in the reed relay (see Figures 24 and 25). The basic reed assembly consists of two strips of magnetic material (nickel-iron) sealed in a glass tube about one inch long, containing an inert gas. The two reeds are mounted almost in line with each other, with the free ends overlapping by about a tenth of an inch and separated by a few thousandths of an inch. The overlapping areas are gold-plated to reduce contact resistance and prolong contact life. When placed in a magnetic field, the two reeds come into contact, thus completing the electrical circuit in which they are connected. The magnetic field is provided by a coil surrounding the reed insert; for most of the applications in the electronic exchange, four reed-inserts are contained in one coil, thus producing a relay with four 'make' contacts.

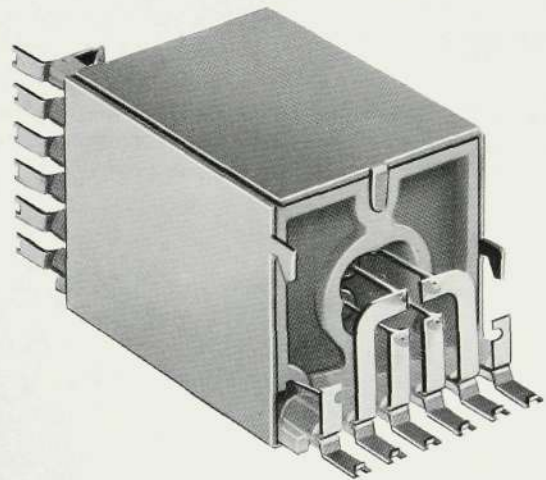
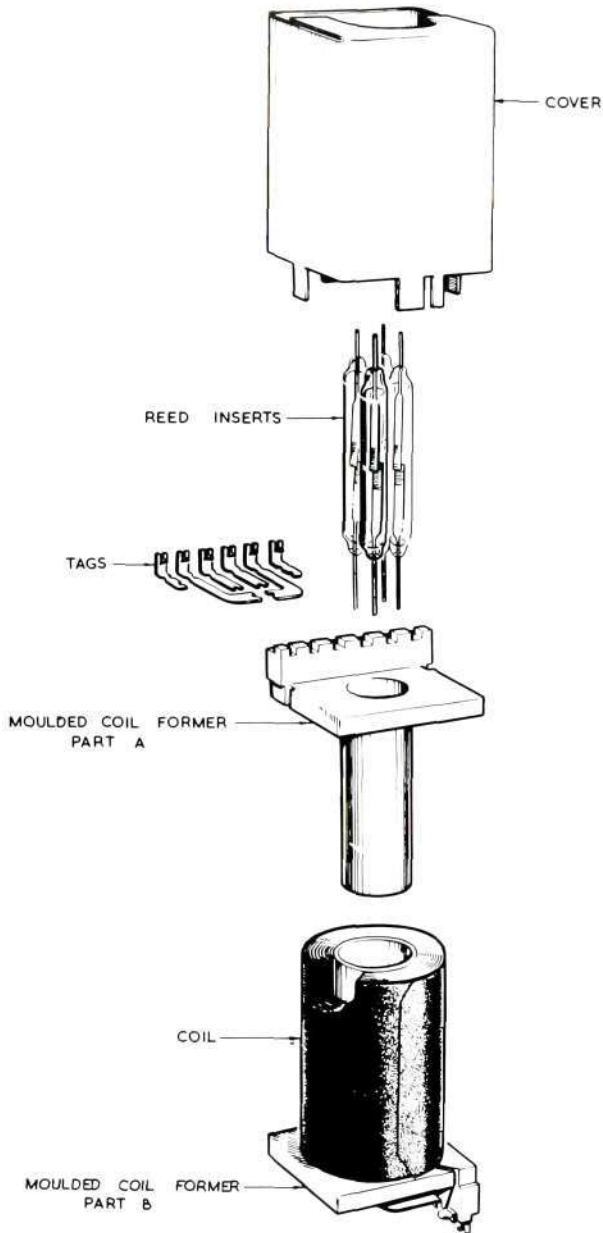

Figure 24—Reed Relay. The overall length is 2" (5 cm). The four inner tags at each end are connected to the reeds; the outer tags are coil terminations



**Figure 25—Constructional details of the Reed Relay.**  
 The cover provides a magnetic return path for the reed inserts and also acts as a magnetic screen

The simplicity of the mechanical movement gives high reliability, and also high speed of operation. The life expectation is greater than  $10^7$  operations, and the 'operate' time is about one millisecond.

The four contacts of the reed relays used as cross-points in the A, B, C, D and other switches are used to connect vertical to horizontal multiples consisting of a pair of speech wires, a private (P) wire and a hold (H) wire. To enable parallel runs of these wires to be readily connected to the reed relays, the terminal tags at one end of the relay are aligned at right angles to those at the other end, the ones in a vertical row being connected to a horizontal multiple and *vice versa*.

The reed relays are also used widely in the control circuits, e.g. for the storage of calling-number digits and dialled digits in the register. Where operation is critical, a relay with a single insert may be employed, since the operation of the relay can then be confined within narrower limits.

## POWER SUPPLIES

The exchange operates from a conventional, nominal 50-volt (negative) exchange battery, i.e. a battery whose voltage can vary between 46 and 52 volts. A 50-volt positive supply also is needed for some of the circuits, and if no suitable supply already exists it can be derived from the exchange battery by transistor inverters. To ensure continuity of power supply, inverters are duplicated. Some of the transistor circuits require small quantities of power at intermediate voltages; these are derived by local voltage regulators from the main 50-volt line on the actual unit where the auxiliary supply is required.

Tone and other supplies from conventional ringing machines, vibrators, or semiconductor devices can be used for the exchange, since conventional signals are given to subscribers. This allows the use of the normal telephone and other subscriber apparatus.

*British Patent Application Numbers 5112 63, 31256 63, 43048 63, 45085 63, and corresponding foreign patent applications*



# ERICSSON TELEPHONES LIMITED • ETELCO LIMITED

A PRINCIPAL OPERATING COMPANY OF THE PLESSEY GROUP

## REGISTERED OFFICE

22, LINCOLN'S INN FIELDS, LONDON, W.C.2  
Telephones: HOLborn 6936  
Telegrams: Ericlond London, W.C.2

## HEAD OFFICE AND WORKS

BEESTON, NOTTINGHAM, ENGLAND.  
Telephones: Nottingham 254831  
Telegrams: Ericsson Beeston Nottingham.  
Cables: Ericnotts Nottingham England.

SOUTHWICK, SUNDERLAND, ENGLAND.  
Telephones: Sunderland 70784  
Telegrams: Ericsson Southwick Sunderland.

## BRANCH OFFICES AND GROUP MEMBERS

### AUSTRALIA

ERICSSON TELEPHONES LIMITED,  
13/17, Botany Street,  
REDFERN, NEW SOUTH WALES.  
Telephones: 69-6861 Telegrams: Ericsson Sydney.  
*Also at 268, Albert St., E. MELBOURNE, C.2, VICTORIA.*  
Telephone: 41-5015.

### NEW ZEALAND

ERICSSON TELEPHONES (N.Z.) LTD.,  
P.O. Box. 3691,  
WELLINGTON, C.1.  
Telegrams: Erictel Wellington

### SOUTH AFRICA

BEESTON ERICSSON TELEPHONES (PTY) LTD.,  
Cape York Building,  
252, Jeppe Street,  
JOHANNESBURG.  
Telephones: Johannesburg 232535  
Telegrams: Erectel Johannesburg.

### CANADA

ETELCO (CANADA) LTD.,  
199, Ashtonbee Road,  
SCARBOROUGH, ONTARIO.  
Telephones: Plymouth 9-4407  
Telegrams: Teltor Toronto.

## GROUP ASSOCIATES

TELEPHONE AND ELECTRICAL INDUSTRIES PTY. LTD.,  
Faraday Park, Railway Road, Meadowbank,  
New South Wales,  
AUSTRALIA.

ERICSSON TELEPHONES LIMITED

ETELCO LIMITED