

contact



PHOTO: JAN NODRÉN

No need to wait for platform

10-12

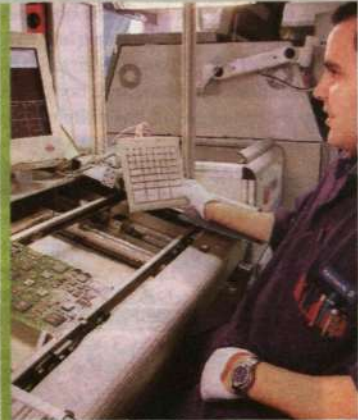

PHOTO: LEIF JÄDERBERG

Milestone for 3G base station

3



PHOTO: MARKUS FISCHER

Men behind large-scale Engine

14-15

no.
November 14,
2002

19

Three employees suspected for espionage 3

Challenging year for DACH 4

Competition for better cash flow 6-7

3G build-out behind schedule 8-9



Business



The idea of a company car just got
a whole lot more attractive.

Driving a company car is nice. And when your company car is a sporty, dynamic
Saab, it's downright fantastic. Declare your independence from the ordinary.
Contact your dealer to learn more or visit www.saab.com.

Three suspected of espionage

Three people, employed or formerly employed by Ericsson, are suspected of espionage against the company. Moreover, two Ericsson employees have been suspended from duty.

Three current and former Ericsson employees were taken into custody by the Swedish Police on November 6th, suspected of handing over top secret information to a foreign power. Following this, two more



Henry Sténson, senior vice president of Communications, is concerned but does not think that the leak will cause any major damage.

employees within Ericsson were suspended from duty. They are not suspected of any criminal activity, but may have broken the company's internal security regulations.

None of the five people involved hold key positions within Ericsson, and Henry Sténson, senior vice president of Communications at Ericsson, does not believe the information leaked will cause any major damage to the company.

"With regard to the investigation, we cannot disclose what kind of information has been handed over. Our opinion today is that the damages are limited. Thanks to the timely handling, the deliveries were stopped."

Also in connection with the espionage case, two Russian diplomats were expelled from Sweden on Monday November 11th. According to Swedish State Secretary for Foreign Affairs Hans Dahlgren, two persons at the Russian Embassy were declared "persona non grata" as their activities were not compatible with their diplomatic status.

TONYA LILBURN
tonya.lilburn@lme.ericsson.se

Gävle celebrates 10,000 3G base stations

Ericsson's 10,000th 3G base station was produced recently at the company's plant in Gävle, Sweden. Thirty-five operators in 24 countries have ordered and installed Ericsson's 3G networks.

"The milestone shipment is really exciting since it is yet another factor that highlights Ericsson's leading market position in 3G," says Torbjörn Possne, vice president WCDMA at Ericsson.

Early in 2001, Ericsson set a landmark as the first telecom supplier in the world to deliver 3G networks for commercial use. Operators in Japan and Europe were the initial customers. In March 2001, the company began delivering commercial WCDMA systems.

The efficiency program at Ericsson has led to a new strategy at the Gävle plant. Having worked only with 2G previously, employees there will now deal with the final assembly and testing of base stations for both 2G and 3G networks. Other changes to streamline production will see the Gävle plant manufacture nodes, while module production is moved to Kumla, Sweden. Gävle will also take over production of mobile switches for CDMA from the San Diego, California plant, and increase its ordering office to handle the new assignments. The entire process of new production and streamlined resources will be complete by mid-2003. The efficiency program has resulted in 305 redundancies in Gävle.



In Gävle, they've counted up to 10,000 in 3G base station deliveries. The first WCDMA base station left Gävle in 1997, to be tested at NTT DoCoMo in Japan.

ULRIKA NYBÄCK
ulrika.nyback@lme.ericsson.se

PHOTO: LEIF JÄDERBERG

Breakthroughs in Latin America

Recent contracts in Latin America demonstrate important breakthroughs on the market for Ericsson. In Nicaragua, operator PCS Digital has chosen Ericsson as sole supplier for a nationwide GSM/GPRS network in the 1900 MHz frequency. Ericsson will also be responsible for implementing and maintaining the system as well as training PCS Digital personnel.

In Colombia, Ericsson is the sole supplier for BellSouth Colombia's new CDMA2000 1X network. Ericsson's end-to-end CDMA2000 1X solution will be implemented on BellSouth Colombia's existing nationwide TDMA network. Commercial launch is expected in early 2003.

And finally in Brazil, Ericsson and operator Vésper have signed a Letter of Understanding to supply a CDMA2000 1XEV-DO overlay system in the capital Rio de Janeiro. The solution will support 3G applications such as streaming audio, video and data transfers. The network is expected to be commercial by mid-2003.

Debut for MMS and 3G in Ukraine

In the first live demonstration of 3G services in Ukraine, Ericsson teamed up with the country's leading mobile operator, Kyivstar GSM, to show UMTS services at a telecom exhibition in Kyiv (Kiev), Ukraine. In addition, Kyivstar GSM and Ericsson announced the successful launch of a MMS trial system. Ericsson is the leading mobile systems supplier to the Ukrainian market.

Four players agree on WCDMA royalties

Four big names in telecom - Ericsson, Nokia, Siemens and NTT DoCoMo - have agreed on royalty rates for Wideband CDMA technology. The idea is that, with combined royalty rates of less than five percent, pricing for WCDMA handsets and mobile networks will be fair and competitive.

The companies together own the clear majority of the essential Intellectual Property Rights (IPR) relevant to the WCDMA standard already chosen by about 110 operators worldwide. This means that any company using these standards need license agreements for the essential patents. The above companies also own a significant number of the essential patents applicable to the CDMA2000 standard. These patents will be licensed at fair and reasonable terms.

Expanded GSM in Bangladesh

Ericsson has signed a contract with Telecom Malaysia International Bangladesh (TMIB) to expand the operator's GSM network. The contract calls for delivery of 160 base stations and is worth USD 43 million. TMIB is the second-largest GSM operator in Bangladesh. With this expansion, the operator hopes to increase its subscriber base from the current 150,000 to 400,000.

MoU with TelecoSite in Israel

Ericsson Israel has signed a Memorandum of Understanding (MoU) with TelecoSite, a firm created to manage, finance and operate joint communications sites in the country. The MoU guarantees exclusive cooperation between the companies to set up third generation networks to be used jointly by Israeli mobile operators Partner, Cellcom and PelePhone, who are currently testing the joint network's business and economic viability. The agreement must still be approved by the Ministry of Communications and Antitrust Authority.

A tough year for DACH

Market Unit Germany, Austria, Switzerland and Liechtenstein, DACH, has celebrated its first anniversary. The road has been filled with challenges, but the visions are growing stronger.

Market Unit DACH has seen a little bit of everything in the past year. The number of operator customers increased from two to eight, just to then see Quam and possibly Mobilcom pulling out of 3G in Germany and Switzerland and cancel their orders with Ericsson. At the same time, Mobilkom Austria and Connect launched 3G networks in Austria a good year ahead of schedule.

"A lot happened in a short time, and everyone has been affected," says market unit head Kristian Teär when summing up the past year. "It was difficult when we started, and then it got even tougher."

Just as elsewhere in the organization, taking control of costs was an immediate goal. Kristian Teär and the management team put every expense under the magnifying glass and cut costs in half. They are just about to cut costs in half a second time.

"But you can't just save yourself to death, you can only live like this during a transition period. And you have to believe in something to live like this," he says with emphasis, "and it should preferably be something that generates profitable growth as well."

The question was how to find a way to be visionary and grow business when there are no signs that the market is recovering. The answer was the vision programs. For about a year, DACH has attempted to halt the recession, working extensively with voice, quality

VISION PROGRAMS

The Vision Programs have generated a number of concrete projects. These are a few of them.

- **Cineman:** A portal available in Switzerland that offers information, movie clips and ticket reservations. This service already sees 70,000 hits every week.
- **Swissclick:** Real-estate offerings available over Voicemail, SMS, wap, and MMS in Switzerland. Fully commercial by the end of this year.
- **Mobihealth:** Targets seniors with chronic diseases. A project partly funded by the European Commission, to be launched in 2003.



A year has passed since the merger and this has been a challenging time for Kristian Teär, head of the market unit.

data and network perfection, with the purpose of increasing customer usage, driving traffic in the network, thus creating a need for more infrastructure. The voice part should not be underestimated.

"After all, voice has been our product for 126 years; it's not primarily switches or circuit boards that we sell. Voice is what everyone can identify with and an area where everyone can make a contribution," says Kristian Teär.

The vision programs have not only led to increased business and cooperation with satisfied customers, but have also resulted in individual initiatives from the DACH employees: the recently concluded talk time contest in market area Europe, Middle East and Africa resulted in 1,700 individual submissions, and the contest is now being launched in market area Asia Pacific.

And the vision programs are not a temporary way of keeping the employees motivated during trying times.

Created independent of technology, they will remain at the core of DACH when the market turns.

"Volume, cost and efficiency will always be relevant. So will the visions. This industry has a gigantic potential that isn't being taken advantage of – we haven't even begun to peel off the opportunities," says Kristian Teär.

"The most important thing is that we believe in what we're doing. You have to be persistent to reach as far as we have, and never give up the search for new ideas. If we can get new projects started where people feel that they can contribute, the organization will be stronger than ever."

ELIN AHLDÉN

elin.ahlden@lme.ericsson.se

www.edd.ericsson.se/vision



Ericsson's headquarters for Market Unit DACH are situated in Düsseldorf in southern Germany.

The question on many minds these days is, "How will Ericsson survive the telecom crisis?" But for the sake of survival, someone's perspective has to reach beyond present tense. Håkan Eriksson, head of Ericsson Research, leads the team that thinks ahead.

Research always a step ahead

"Sometimes we have to think two to three years ahead, sometimes up to ten years. But you can also be much shorter in perspective," Håkan Eriksson explains. "Today we're focusing a lot on applications for 3G to make them really work, what bit rates are needed for certain applications to make sure you can get them in an efficient and appealing way for the end user."

Ericsson Research sees to it that Ericsson is technically ready for the future. "We have a mission to develop the technology and to spread the gospel about 3G," says Håkan Eriksson, who is often invited to seminars and public appearances, where he presents concrete examples of that.

"An MMS postcard can use very low bit rates. If it contains a little music, it's only two kilobytes. You can send 25 kilobytes on GPRS for a low price," he states. But to see moving, synchronized video, you need 50 kilobits per second for simple news and 200 kbps for sports. Continuous movement at 200 kbps requires a broader network - 3G.

Slightly more than SMS

Håkan Eriksson doesn't want to go overboard with the possibilities in 3G. "It's a misconception that people will watch movies and it will cost a month's salary. 3G will in the beginning be used for short clips, ranging from 10 to 20 kilobits to up to 200 kilobit clips that are 10 seconds long. And it will cost only two or three times what an SMS costs," he foresees.

Research and Development is undergoing the expansive concentration program, but it's primarily Development that is affected. "We have to match the market situation. We are scaling down also in Research. Our way of working is to rotate people out of the research organization into the development organiza-

tion every few years anyway, so we continue to feed the freshest ideas into the company."

Standards are key

Another way of working at Ericsson Research is to focus on standardization. Ericsson leads the market in WCDMA contracts (35 to date, in 24 countries). Håkan Eriksson says that's largely due to work on standards.

"We make sure ideas from Ericsson become standards. There's a direct correlation between how much Ericsson has contributed to standards and how many contracts we get in that area."

Crazy ideas are welcome, but mostly Ericsson Research enhances and develops existing ideas and technology. Håkan Eriksson recalls fighting to get 9.6 kilobits for GSM, which is now at least the standard in those networks. Crazy, in other words, is relative. "We're not walking around in lab coats being sort of distant from the world," he continues, "We have to prepare for future market share."

DODI AXELSON

dodi.axelson@lme.ericsson.se

Håkan Eriksson, head of Ericsson Research, foresees that sending a film clip using 3G will not be much more expensive than SMS.

PHOTO: LARS ÅSTRÖM



Competition element spurs

Proactive is an important term for reducing tied-up capital, especially accounts receivable and inventory. By working proactively and assuming a clear distribution of responsibility, most market units within market area Europe, Middle East and Africa (EMEA) have made distinct progress in reducing tied-up capital. Some of this work has turned into a competition between the market units.

"Efforts to reduce tied-up capital began in spring 2001, when each market unit appointed a capital controller – a capital economist – to take control of the market unit's tied-up capital. Earlier, this had been conducted in different ways and by various people in the units," says David Ekberg, head of Business Control at EMEA. He is the man coordinating and driving the work to reduce tied-up capital, but, naturally, the bulk of the work is being done in each market.

To avoid reinventing the wheel, David Ekberg studied what some other large companies had done to improve their cash flow.

"Volvo is an excellent example. It has been very skilled and has made huge progress," he says.

An important feature of the improvement efforts has

been to build a network for the capital economists. This has facilitated the exchange of experiences and made it possible to learn from each other.

Everyone involved

Clear goals, regular follow-ups and participation are other significant components in the endeavor for improvement.

"Two months after we began the improvement work, we had all managers on track. Once or twice a month, we hold a teleconference with each market and the capital economists report on progress in



David Ekberg

their own market units. For major capital issues, the head of the market unit also participates in the teleconference," explains David Ekberg.

A/R on live, where A stands for accounts and R for receivable, is a system that enables the daily follow-up of an invoice and to see what has been paid.

"Earlier, we often waited until the final payment date. Now we work proactively and call the customer in advance to ensure that everything is in order and the customer has everything ready for payment. In this way, we can also build up solid relations with whoever is responsible for the customers' payments. This generates respect from the customer," David Ekberg notes.

Work with the customers also involves simplified payment procedures.

Wherever there looks like being a problem with a payment, the matter is handed to Ericsson's KAM or the head of the market unit.

At EMEA, overdue accounts receivable have been reduced by a third. Improving cash flow and restricting accounts receivable is not only a task for the economists.

When a contract is signed, the payment times should already be negotiated and it should be clear when Ericsson can invoice charges.

"It is extremely important that those working with logistics ensure that supplies are complete and arrive on time. For example, if a cable is missing, it could mean that we don't get paid until it is provided. At its

cash flow

extreme, you could say that a USD 2 cable might incur a payment delay of, say, USD 50,000," David Ekberg explains.

The flow of capital has also been affected positively by Ericsson now delivering equipment in standard packages rather than the earlier special solutions.

Competition encouragement

In cooperation with Ericsson University, David Ekberg was one of the initiators of The Way Cash Flows, a Net-based training course on cash-flow principles. It has had a major impact and more than half of EMEA's employees have undergone this training.

"We achieved an excellent result. I believe this is partly explained by a competition developing between the market units to have as many participants as possible. At the monthly meetings held by all market unit managers in EMEA, we review the financial figures and compare the units' situations in terms of tied-up capital. Using stars, storm clouds and pictures of the 'best' managers, we create a visual effect that encourages further improvements," says David Ekberg.

GUNILLA TAMM

gunilla.tamm@lme.ericsson.se

university.ericsson.se/training/finance

Early action makes the difference

The weekly follow-up of accounts receivable is an important feature of efforts to improve cash flow at market unit UK and Ireland. It has generated positive results and, during the past twelve months, the number of days between an invoice being issued and receipt of payment from the customer has diminished considerably.

Slightly more than a year ago, the market unit began working more efficiently to set its cash flow on a positive track.

"We introduced certain work processes and rules that we are careful to follow. One of these involves the regular review of the customers' credit-worthiness. Every new customer is scrutinized for its ability to pay and its prospects. If Ericsson is to grant credit, the decision in all cases must be approved by the head of our market unit and myself," says Graham Truran, director of Finance at the market unit.

In some cases, further approval is required and this is handled quickly. Close cooperation with the employees working with customer finance is important. This contact begins as soon as the first business opportunity emerges.

"Our success in minimizing total credit periods is due to being proactive. We address accounts receivable before they become a problem, which is before the final date for payment. The employees who are involved with

receivables meet the customers regularly. When questions arise about specific invoices, Ericsson key account manager and someone from the credit group go through these with the customer. They work as a team," notes Graham Truran.

"Achieving favorable results in our work to improve cash flow is attributable to the employees' commitment and fine efforts, and that the managers are providing solid support. The SAP operational system was recently introduced at the market unit. This gives us the opportunity to improve our work processes that harmonize with the systems support in the interface with the customers. If we and the customers use systems that speak the same language when they submit orders to us and we invoice them, it will be easier to receive prompt payment. The customers also seem to appreciate this simplification," he concludes.

GUNILLA TAMM

Control and clear contracts important

Benelux – Belgium, the Netherlands and Luxembourg – is one of the market units that has been successful in its efforts to reduce tied-up capital.

"Acceptance and payment terms, timely invoicing and strict follow-up of receivables are issues that must involve the line organization. And it is especially important that the account managers discuss these issues early in the negotiation phase of a project," says Danny Witjes.

"My role as a capital manager also includes training for colleagues. Everybody must understand how to influence the cash flow of Ericsson. This year the Web-based training course 'The Way Cash Flows' was introduced for all employees. And for those who work directly with customer contracts, a specific course on cash planning in projects was rolled out in the Benelux. Planning and control of project cash flows is an area in which we have witnessed progress. But there is still significant potential for improvements. Strict project control, from business opportunity to customer acceptance of delivered products and services, is vital to achieve this," concludes Danny Witjes.



Danny Witjes

"The focus on cash flow strongly increased in the Market Unit Benelux in spring 2001. And at the same time activities to reduce the working capital were intensified all-over in Market Area EMEA," says Danny Witjes, capital manager for Benelux.

The capital cost for ongoing projects (work-in-progress) and receivables, got full attention in the increasingly tough business climate. A clear cash target was set for 2001, which was achieved by year-end. This implied a significant reduction in capital employed within the market unit.

GUNILLA TAMM

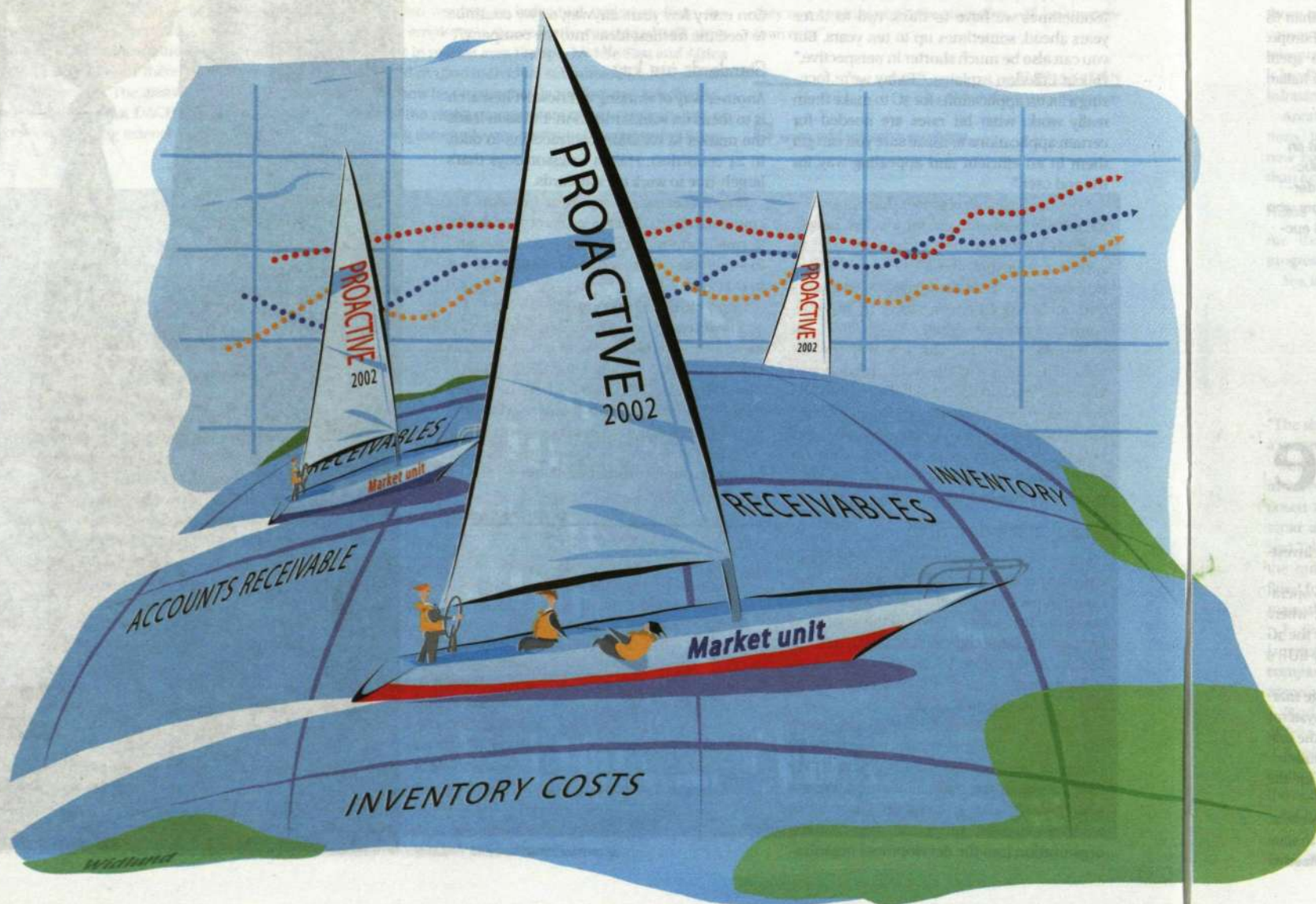

The ability to demonstrate as favorable figures as possible for tied-up capital has turned into a stimulating competition for the market units in market area EMEA.

ILLUSTRATION: LASSE WIDLUND

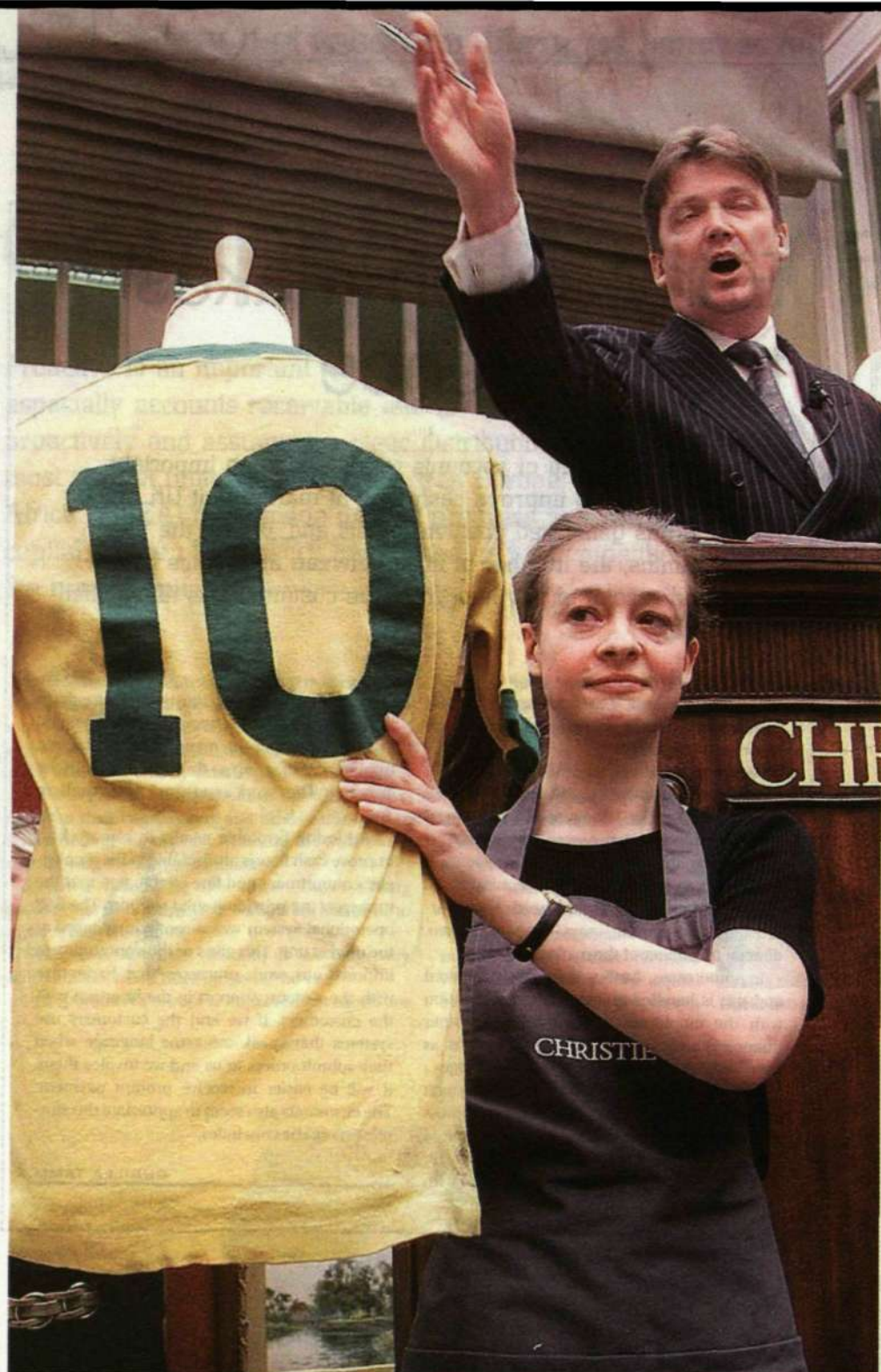

Costly delay

The European build-out of 3G is behind schedule. The question is, by how much? To date, a handful of operators have reneged on their license commitments and about as many have announced postponements of their 3G startups. The latter group may well grow next year. But now the regulators have begun to make it easier for the operators to get things moving.

The shock waves followed each other in rapid succession when the bidding for 3G licenses began in Europe two years ago. In many cases the prices were astronomically high. While most countries organized some form of "beauty contest," the really large markets auctioned off the licenses.

In Germany, the government took in EUR 620 per inhabitant for each of the four licenses issued. The operators ended up paying an incredible EUR 9 billion for their permits. In the UK, the most expensive license fetched EUR 11 billion, while licenses in Italy were sold for around EUR 2.5 billion.

Now the results are partially clear: more than 65 operators have been awarded 3G licenses in Europe. Two of the operators in Germany who spent more than they could afford, and one of the Italian

A shirt worn by soccer legend Pelé was sold at an auction for EUR 257,000. One wonders if the successful bidder in this case does not feel considerably more satisfied than the European operators who also forked out huge sums of money in the 3G auctions two years ago.

PHOTO: PRESSENS BILD

Optimal model still elusive

In countries like Sweden and Norway, it is the authorities who determine how rapidly the build-out of 3G should proceed. In Germany and the UK, the market decides. "It is impossible at present to say which model drives development more rapidly," says mobile telephony analyst Anna Lange.

The fact that the license models vary among European countries is not solely due to differing political attitudes. Demographic differences and settlement patterns also play a role.

"It is natural that in thinly populated countries, such as the Nordic countries and Ireland, the prices charged for licenses are not so high, since the operators still face heavy costs to provide services to their most remote

customers," says Anna Lange, strategic mobile telephony analyst and author of a report produced recently by consulting company Northstream for the Swedish National Post and Telecom Agency.

In these countries, the regulators imposed rigorous requirements regarding coverage, since there is no natural financial incentive for operators to build out their infrastructure in sparsely populated areas.

In the more densely populated countries further south in Europe, it is sufficient for the operators to construct 3G networks in a few of the major urban areas to achieve 70-80 percent coverage of the population.

"In these regions, there is no point for the authorities in focusing on coverage requirements. Instead, they bring pressure to bear on the operators by charging high prices for licenses, so that they must get their

networks functioning quickly to recoup their investment."

Now it looks very much as if the pressure on operators has been excessive, at least in Germany, where two of the four operators have withdrawn from the 3G fiasco, severely mauled by license fees of nearly EUR 9 billion.

"On the other hand, the operators in the large markets have been given plenty of time to get their systems up and running," continues Anna Lange. "In some cases, no time limit has been imposed at all - the authorities are counting on market forces to speed up the build-out."

Anna Lange notes that it is impossible at present, after the withdrawals and postponed launches, to state which business model will prove the most effective.

licenses launches

license-holders, have withdrawn and currently have no new plans to invest in 3G networks.

Several other operators have shelved their 3G plans, but these are active in smaller markets, such as Austria and Switzerland.

Launches delayed

Several operators have announced that they are postponing their commercial launches. The delays range up to six months and mainly affect the three largest markets: Germany, the UK and Italy. In addition, a roughly equal number of operators have requested extensions from the relevant authorities, but not yet received a response.

The operators that are most in the public eye at the moment are Vodafone and Orange, which hold the largest number of licenses in Europe and have promised to begin commercial operations during 2003. We do not yet know whether this will happen, but what is clear is that Vodafone is behind schedule in all its markets, compared with the promises the company made initially.

So what are the causes of the delays affecting the commercial launch of 3G mobile telephony?

One reason, of course, is shortage of money. But those operators that had to cough up billions for licenses are not the only ones in difficulty; the entire telecom industry is in dire straits financially and this is hardly the ideal time for major investments in new infrastructure.

Another reason is local building-permit regulations. In some areas, there is strong resistance to new base stations, and it has been taking longer than expected to resolve permit issues.

Rules vary

Are the authorities doing anything to facilitate progress on the 3G front in the European countries? Yes, it is fair to say. At EU level, considerable efforts

have been made to harmonize the rules for joint utilization of network infrastructure. In this regard, Sweden differed from other countries in that it had permitted joint utilization of networks from the start, allowing the Swedish National Post and Telecom Agency to declare triumphantly that this increased rather than decreased competition.

Since September there has been an overall EU permit for shared networks, but the rules still differ between countries. There are differences, for example, regarding the network level at which operators are allowed to share equipment.

From a financial viewpoint, it is difficult for the authorities to do anything. They can hardly change the conditions in those countries where the licensing process has been completed. But in France, where all the licenses have not been allocated, reserve prices were reduced after a series of auctions. France has also, like Italy, extended the license period from 15 to 20 years.

In Spain, Belgium, Portugal and Switzerland, the authorities have eased the requirements regarding the build-out rate - but they were unusually tough to begin with.

In those countries that obtained such enormous prices for licenses, the regulatory authorities have now granted operators the right to sell them. Licenses cannot be sold until 2007 in Germany and 2005 in the UK.

In Germany, the possibility of letting the unutilized licenses revert to the government has also been discussed, but the issue has yet to be decided.

MARGARETA JONILSON

edited by:

SARA MORGE

sara.morge@ime.ericsson.se



Anna Lange, strategic mobile telephony analyst at Northstream, believes that the future will show whether it is the authorities or the market forces that will drive 3G development most rapidly.

PHOTO: GUNNAR ASK

China ponders 3G standard

The Chinese government wants the country to have its own 3G standard and has announced the formation of an industrial alliance comprising equipment producers, financiers and operators, focusing on the new TD-SCDMA standard.

The country's four major operators were parties to the announcement, but were represented only by mid-level management. The absence of top executives when the announcement was made, has prompted speculation that they do not support the idea. Representatives of the Chinese operators have also stated publicly that they do not believe that TD-SCDMA has an especially good chance of becoming the leading Chinese 3G standard.

The Chinese government has been evaluating CDMA2000, WCDMA and TD-SCDMA during the past year and is expected to announce in the near future which standard it intends to support. The government's purpose in promoting a proprietary standard is naturally to strengthen China's own industry and impede competition from outside the country, but many analysts believe that China may nevertheless end up supporting more than one 3G standard.

Chirac urges 3G-support

French president Jacques Chirac is urging the EU to hasten development of 3G through support measures.

"The telecom sector is undergoing a serious crisis, resulting from the lack of a Europe-wide policy at the time of the absurd process whereby licenses were allocated within the EU," Jacques Chirac is quoted as saying by the Total Telecom webzine.

Jacques Chirac now plans to write to all the EU member states with the aim of devising a rescue plan for the telecom industry. He is also requesting that the European Commission present proposals for measures to facilitate the build-out of 3G.



Jacques Chirac

Upturn for France Telecom

France Telecom was at last able to present improved figures in its third-quarter report, but is still adjusting its full-year forecast downward. Earnings during the first nine months increased by 9 percent. Sales of EUR 11.97 billion were in line with expectations and 7.1 percent better than for the year-earlier period.

A solid third quarter

AT&T Wireless presented a strong third-quarter report. Revenues from mobile services rose 16 percent to USD 3.76 billion. The average talk time per subscriber also showed an increase - from 389 to 484 minutes.

"AT&T Wireless is once again able to present a quarterly report with solid financial results in virtually all measurement areas. We reported a strong increase in revenues and earnings before tax and depreciation amounting to nearly USD 1.1 billion, which is our best result ever," says CEO John D. Zeglis.

Subscribers swap photos

Japanese operator J-phone now has more than seven million subscribers with camera-mobiles. Sha-mail users have increased by more than one million over the past two months and now make up 54 percent of J-phone's total customer base.

J-phone sells some 20 different mobile phones with Sha-mail capability, six of which can handle Movie Sha-mail, a service that enables video clips five seconds long to be mailed.

MARGARETA JONILSON

Tough teamwork results in best 3G platform

The platform team in Lund managed what nobody thought possible. In record time, they produced a solution for a 3G mobile that can handle broadband and dual mode between GSM and WCDMA.

The beginning was tough. In spring 2001, Ericsson's mobile operations were still running at a loss totaling billions, the former Consumer Products division was being broken up and employee motivation was at a low. This meant that conditions were the worst conceivable for tackling what was perhaps the most important and complicated project to date in Lund – development of a platform for a 3G phone.

Up to eight hundred people have been, and still are, involved in the project, which has a German-Swedish management duo: Bernd Möller is project manager and Torbjörn Sölve heads up the systems-management project.

"At the beginning, we said that the platform would be ready to be shown on September 27 and this time alone was regarded as too short by many," says Bernd Möller.

"However, in mid-March, when we were celebrating the completion of part of the project – our single mode platform – Nokia had just announced that September 26 was its 3G date. So at the party that evening, I stood up and declared that we would finish before the Finns."

This was the major starting shot for the project and, on September 24, it was demonstrated to the world that Ericsson Mobile Platforms has a functioning platform

that can handle the handover between GSM and WCDMA and a data transmission speed of 384 kbits/s.

But this project has certainly been no walk in the park. One problem was posed by the application-specific integrated circuits (Asic) that needed to be designed. For example, the main base band Asics had to be in place on record time to keep the schedule, and in the platform there are several other key circuits that also had to be developed.

Close cooperation

The only way to manage this was to initiate tremendously close cooperation with the circuit manufacturers to rapidly and smoothly resolve any and every problem that could threaten the process. However, in other areas of the project, there were people who did not believe that the circuits would be ready in time. This led to other parts of the project falling behind.

"I told those responsible that they would be the ones forced to inform their colleagues why their parts weren't

ready in time. They then understood the seriousness of the matter," continues Bernd Möller.

An important task for the project management was to adapt the organization to suit the project.

"Previously, each area was a separate kingdom and the activities were not so well synchronized. Our software and our base band were excellent, but they didn't function together. We wanted a complete story, with the entire company working as a team," says Bernd Möller. Torbjörn Sölve adds:

"Before, we had strong departments and weak projects. Now it is a much better balance where the project steers the daily operations. We also reorganized and now we are structured to suit the platform's architecture."

Motivation is key

However, the most important aspect has been motivation and inspiring a somewhat disillusioned workforce to make a fresh go of things.

"What made this project possible was really hard and

focused work from all staff members. We are extremely grateful for the energy everyone has contributed to make this a success. I must say that it has cost a lot of effort and overtime," notes Torbjörn Sölve.

"We had a task ahead of us that many regarded as impossible to fulfill. But I asked everyone to do his best. I didn't expect anyone to perform miracles, but if everyone did their best, we could bring about a miracle together – which we did," says Bernd Möller.

Hardware is ready

The next step is to complete the work on the architecture. The hardware is ready, and a test model is already shipped, but some software remains to be developed. A schedule has been established, which means that mobiles based on the platform can be in production by first half 2003 and EMP's key customers are fully occupied in preparing designs, user interfaces and applications to ensure that everything is in place for the commercial launch.

The building-block structure of the architecture is designed to enable use of the same architecture for several platforms.

"We are making regular releases of functionality to our customers and with the motivation that exists in the organization, I know we can meet all the tough dead lines for this," concludes Bernd Möller.

Dual mode for test purposes

Sony Ericsson, which is Ericsson Mobile Platform's largest customer, will have terminals ready for GSM/WCDMA at the end of 2002. The mobiles will reach the shops during the first half of 2003.

"But already now, we are delivering dual-mode terminals to operators for test purposes," says Peter Bodor, press officer at Sony Ericsson.

LARS-MAGNUS KIHLESTRÖM
lars-magnus.kihlestrom@ime.ericsson.se



Torbjörn Sölve is head of the systems-management project and Bernd Möller is project manager for the new mobile platform that can handle both GSM and WCDMA, so-called dual mode. "Everyone has done a fantastic job to help us manage this," says Torbjörn Sölve. Phones based on the platform will be in the shops during the first half of 2003.

PHOTO: JAN NORDÉN

Frog in the cream

As an illustration to motivate his coworkers, Bernd Möller used the following story.

A frog lands in a large bowl of cream and is unable to get out. What should he do? The overoptimistic frog thinks: "I'll drink the cream and jump out." This frog would choke on the cream and go under the surface.

The pessimistic frog believes this situation to be hopeless, gives up and sinks to the bottom.

However, the realistic frog thinks: "I'll do my best!" He starts to swim and kicks with his frog feet and succeeds. Why? Because when the frog has been kicking for a while, he notices that the cream has been whipped into butter and he can jump out of the bowl and onwards to new adventures.

PLATFORMS

A mobile platform is a reference design which can be described as the inside of a mobile phone. Ericsson Mobile Platforms develops the electronics and software that are contained inside the shell and sells the solution to mobile manufacturers. About 1,000 persons are employed by the company. The headquarters are in Lund, southern Sweden.

The customers include major players in the mobile phone market, such as Sony Ericsson and LG Electronics, as well as manufacturers such as TCL and Benfon.

The do-everything platform

The 3G platform developed in Lund is probably the world's most advanced. Ericsson is at least unique in having demonstrated that the phone can handle a data transfer speed of 384 kbit/s and handover between WCDMA and GSM networks.

The architecture on which the platform is based is modular. This means that the parts combine to form a functioning entirety, in which some parts can be selected or omitted. In this way, more platforms – simpler or more advanced – can be developed from the same basic design.

The architecture supports all UMTS standards, that is, WCDMA, GSM/GPRS and EDGE. It is impossible not to be impressed when you see what the system can do. Naturally, in addition to broadband transmission and dual mode, there is support for all multimedia standards, such as mpeg4 and mp3, as well as video filming, streaming video and video telephony.

To handle large amounts of data, the architecture supports external memory cards, both Sony's memory stick and MMC. Of course, the mobile has WAP 2.0 and, for positioning services, there is support for GPS, among other functions. Furthermore, those who

choose this platform can have a display of 65,000 colors and the size of a PDA screen on their phone. The ring signals are, naturally, polyphonic and MIDI-controlled.

The architecture can also communicate via USB, in addition to the usual wireless interfaces, such as Bluetooth and IrDA.

Handover important

Many parts of the architecture are complex, but the handover function between GSM and WCDMA is undoubtedly one of the most important.

"It is complicated because there must be activity in both the GSM and WCDMA sections and then they must be synchronized for a seamless handover. But now we are demonstrating that it works," says Kjell Gustafsson.

The major benefit of being able to switch between

WCDMA and GSM is that 3G coverage need not be complete already from the outset, but can be built out gradually.

It has also been demonstrated that the platform can handle broadband, which is 384 kbit/s.

"We simply connected a PC and ran a video film on it with the phone as a modem," Kjell Gustafsson continues. "We wanted to show that we had stability and capacity for the high data speed. The difficulty is that, the more bits, the larger the calculation, and this requires processor capacity. We actually conducted the first successful tests with 384 kbit/s at the beginning of 2001 and since then there has been no talk of reducing speed. Nevertheless, I believe that we are currently rather unique in being able to handle this speed."



Kjell Gustafsson

Spring leaf for tests

For test and demonstration purposes, and to show customers a functioning product, a clam-shell model prototype with built-in antenna was prepared. Internally, this is called Wakaba, a Japanese name that roughly translates as "fresh spring leaf" and also means "beautiful young woman".

"We believe it is important to point out that we are not selling a bag of circuits that the customer can assemble the best he can. Instead, we are offering a well-conceived design for hardware and software, in which each part has a well-defined function. We also test to ensure that our products are compatible with the mobile systems, both Ericsson's and others."

"When we have completed this architecture, the next will follow. There are many parts of the UMTS standard left, such as specifications of data speeds for more Mbit/s. But we are taking it one step at a time," says Kjell Gustafsson.

LARS-MAGNUS KIHLLSTRÖM

lars-magnus.kihllstrom@lme.ericsson.se

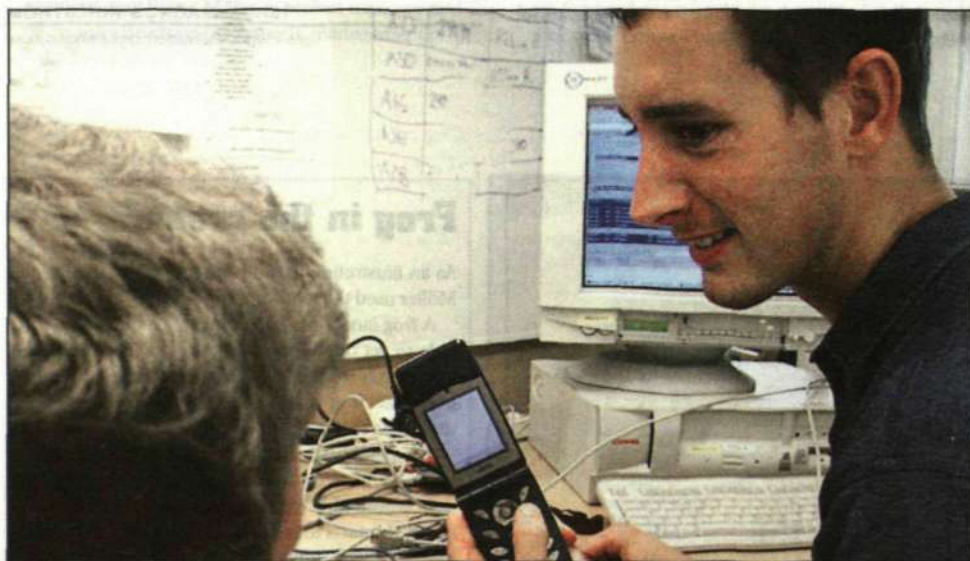

Ericsson Mobile Platforms has developed a phone prototype with the GSM/WCDMA platform. The prototype has a built-in antenna and can handle 384 kbit/s. Development engineer Per Josephson conducts a test.

PHOTO: JAN NORDEN

make your own 3G phone

Ever thought about building your own 3G mobile phone? Here's how:

1. Before you start, you will need to purchase the right to use Ericsson's mobile dual-mode platform for GSM and WCDMA with a 384 kbit/s rate. For the license fee you will receive a circuit board design, the right to use a number of ASICs (Application-Specific Integrated Circuits) developed by Ericsson and software for all basic functions.
2. Begin by designing the case and the mechanical components. Do you want a camera? How big should the display be? Do you want to be able to plug in external memory cards? What modifications of Ericsson reference design for the circuit

board will be required to get it fit in the case? These questions must be considered carefully.

3. Then modify the software to support the accessories you have chosen. Cameras, for example, function in different ways, as do displays. This is why some parts of the software are open source and may be modified.
4. The next step is to begin designing menus, functions and applications. This work can be reused with other Ericsson platform solutions, since they are based on well-defined and open APIs (Application Programming Interfaces). Ericsson can also assist you by suggesting third-party developers.

5. All you need to do now is build a press for molding the case and machines for manufacturing circuit boards and assembling the phone so that production can begin.

6. Start phoning! You don't need full 3G coverage, since the phone works in both WCDMA and GSM networks, thanks to the handover function. Good luck!

However, there is a shortcut. Those who don't have all of these resources, but nevertheless want their own brand of phone, can contact an original design manufacturer (ODM), who specializes in developing and designing phones on behalf of others based on an Ericsson platform.

Common ground for product managers

In small companies, a product manager takes charge of a product life cycle and for all things having to do with the product portfolio. But in a company of Ericsson's size, there are many products as well as product managers. Ericsson University makes sure that all product managers work toward the same goal and learn how to get closer to customers.

It's not a complicated mystery, but being a product manager at Ericsson does require certain deductive skills. Ericsson University's Product Management Curriculum takes students through different areas of focus while opening new channels to make Ericsson more customer- and market-driven.

"We give students part A and B, and let them figure out the rest. By the end of their learning, we want students to feel smarter than the teachers!" declares Per Henningsohn, who designed the curriculum.

He's referring to "modules" or "sessions" on topics like Strategic Pricing, Communicating Value, Product Innovation Strategy & Business Intelligence, Business Economics, and Product Packaging. In the latter, students delve into the new philosophy of selling functionality, not a product.

Per Henningsohn illustrates: "Take cables for instance. When Ericsson would change the color of the

cable, customers thought they were getting something different. By selling functionality, we gain flexibility and can even get closer to the customer's needs."

Identifying customer needs is naturally a big part of the curriculum. "It's an undercover business training, in a way," adds Per Henningsohn. "We can no longer develop just good things. We have to identify what the customer wants and needs, and then develop that."

Students from all backgrounds, from beginners in product management to those with years of experience, are encouraged to begin with "Understanding the Product Management Function." Its aim is to bring product managers from the broad range in the organization onto the same starting ground.

Nearly 300 employees have already earned diplomas, and the University is offering a special deal to bring in another crop of students to Stockholm November 11-21. Or, instructors can travel to give on-

location sessions. That's been done with much success already in Canada, Denmark, and Market Unit Iberia.

"We've seen it all from the product management view," says Canadian Russell Fralich, product manager for TDMA in Business Unit Systems. "But since we are in Montreal, six time zones away, people don't necessarily have the same understanding of how they drive things in Stockholm. This course gives a common view of what product management should be throughout all of Ericsson."

Russell Fralich has made it mandatory for his team to complete the course. (An instructor is going to Canada.)

"This will pay off because managing the product life cycle well improves the bottom line. And, it maximizes career opportunities for employees because it adds to their competence."

After a completed course the graduates receive a diploma.

DODI AXELSON

dodi.axelson@lme.ericsson.se



university.ericsson.se/training/business/default.asp

Future included

Feeling a need to change? The Roxtec cable entry seals have spare capacity included in the system, which means that you can keep adding cables without adding cost.



The ingenious multidiameter technology provides a perfect fit to any cable size, and our tailored cable entry kits allow you to save time and money in all phases of your project. ■

Roxtec International AB
Box 540, 371 23 Karlskrona, SWEDEN
PHONE +46 455 36 67 00, FAX +46 455 820 12
EMAIL info@roxtec.se, www.roxtec.com





Close cooperation created



UK-based BT currently operates the largest "Voice over ATM" (VoATM) telecommunications network in the world. The introduction of VoATM into the BT network is described as the biggest change in voice technology since the conversion from analog to digital in the 1980s. The new technology solved both threatening capacity problems and, at the same time, significantly reduced the operator's network costs. The solution is now a part of Ericsson's Softswitch program.

During the late 1990s, BT faced some major challenges. It had to quickly find a solution that could meet the rapidly increasing demand for trunk network capacity. The booming Internet traffic was causing severe growing pains in the transport network. At the same time, the deregulation of the British telecom market had led to a number of new operators who were demanding more transmission capacity from the former incumbent. It became clear to BT that extending its network with traditional narrowband circuit-switched technology was no longer cost effective.

Faced with this challenging situation, BT decided to introduce the state-of-the-art "Voice over ATM" technology into its core network. This technology could reduce the operator's network costs by up to 60 percent while providing a foundation for a future-secure, highly scalable network - a network that could also cope with future Internet protocol-based services (IP/MPLS).

"BT clearly had to take a radical approach and adopt a wholly new technology to achieve the performance and cost benefits expected by both customers and shareholders," says Geoff Robinson, delivery projects manager at BT. "In addition, Ericsson and BT had to find a way to introduce the new asynchronous transfer mode (ATM) technology into the core network with

Bert Nilsson, NGS program director within Ericsson, Geoff Robinson, delivery projects manager at BT, and Tony Williams, senior network consultant at Ericsson UK, represent the group that built the largest Voice over ATM network in the world.

largest Engine network

the absolute minimal impact on existing customer service."

Prestigious contract

In an extensive international tendering process, eleven major telecommunication vendors bid for BT's prestigious Next Generation System (NGS) contract. By the end of 1998, the outcome was clear with Ericsson emerging as the successful winner.

"For Ericsson, it was a major task both to develop the next-generation switches, which are today the cornerstones of the successful Engine concept, and to implement a new technology not previously used for the handling of carrier scale telephony traffic," says Stefan Feniuk, BT key account manager at Ericsson UK.

"The Engine solution as designed for the market needs of BT has today been further developed into a global product with application for a wide range of operators," Stefan Feniuk adds. "The experiences from the BT project will be of great importance to other customers who need to expand the capacity and/or lower the cost of operation of their network."

A key element of BT's and Ericsson's NGS strategy was to use fewer, but significantly larger switches to provide a high-capacity, manageable network. The adopted strategy was to first install NGS narrowband switches and then follow up by upgrades to Engine Integral server solutions.

This new network solution would solve BT's capacity problem. But to ensure that BT could meet the forecast demand and regulatory obligations for switch port capacity, the operator, in close cooperation with Ericsson,

This has been an extremely challenging program that achieved extraordinary results.

Bert Nilsson



son, had to develop a new faster process to introduce the new switches into the trunk network. The main objective was to keep up with the heavy demand for new ports and replace existing equipment during ongoing operation.

"This new method, which has become known as the Big Bang Changeover or Hot Swap, has already been completed 70 times for narrowband NGS switch cut-overs and 16 times for the introduction of Engine Integral broadband switches, all-in-all with minimum disruption to customer service," says Geoff Robinson. "The smooth change-over process is a credit to the excellent teamwork and partnership across BT Wholesale, BTexact Technologies, Ericsson and also Marconi."

No downtime

The operating experience with the VoATM network has so far been excellent. The total network solution and performance of Ericsson's 60 Gb multi-service switch, the AXD301, easily meets the quality-of-service requirements, and there have been no network downtime. Neither voice quality nor service perception have suffered, thanks to effective echo cancellation.

Geoff Robinson: "There are no issues on interfacing

to other operators, mobile networks or international gateways. As a matter of fact, the network performance has been so reliable that there is almost a risk that our field engineers do not learn the maintenance skills."

One Engine node can handle 30 to 40 million voice calls per week and in the total network more than 7 billion calls have already been successfully passed. With the ongoing NGS program, one narrowband switch is upgraded every week during the autumn, which in turn results in a doubling of network size and capacity. By year-end 2002, 23 VoATM-based nodes will carry approximately 50 percent of all trunked traffic in BT's network.

"This has been an enormously challenging program," says Bert Nilsson, NGS program director at Ericsson. "By working closely with BT, we have achieved some extraordinary results. This has also given us very valuable experience of transforming traditional voice networks into powerful multi-service packet networks, where our products perform excellently in the toughest possible environment."

MARKUS FISCHER
contact@ime.ericsson.se

VoATM - leading edge technology



The Engine solution

Introducing an Engine Integral server based on ATM technology offers several valuable advantages for an operator like BT:

- Access to extremely high-capacity switches.
- The possibility of using logically, instead of physically, meshed trunk network, enabling the operator to considerably reduce its transport network costs.
- A direct connection between switches that support ATM-to-ATM switch operations via broadband links at 155 Mbps.
- Reduced space requirements and energy consumption, as well as fewer different types of circuit boards, means considerably lower operating costs.

Using packet-based protocols such as VoATM for carrier class telephony involves qualitative challenges, particularly in the area of delay and echo. Ericsson worked with BT to resolve the problem of delays in the network. A new interface technology that cost-effectively handles echo cancellation in large call volumes was developed for the AXD301.

The NGS program consisted of two main phases: In Phase 1, the narrowband NGS switch offered approximately twice the capacity of the existing trunk network switches that were replaced. In Phase 2, traditional AXE10 technology was combined in a hybrid configuration with the AXD301 broadband switch in an Engine integral solution.

This Engine Integral solution, today a vital part of Ericsson's "Softswitch" Program, is a combination of a telephony server and media gateway. The telephony server provides to call-control functionality (call control "layer") and the logic to combine AXE10 and AXD301. The media gateway takes care of the switching/cross-connect functionality (bearer "layer") by means of an ATM-based AXD301 switch.

if

you need to deliver a better product while lowering costs

then

take advantage of business rule technology through the partnership between ILOG and Ericsson

To see how ILOG is already at work in Ericsson products visit <http://ericsson.ilog.com> or contact us at ericsson@ilog.com
©2002 ILOG, Inc. All rights reserved. ILOG and the ILOG logo are registered trademarks. All other brand, product, and company names are trademarks of their respective owners.



Changing the rules of business™

WANT TO FIND THE KEY TO FAST AND SUCCESSFUL
BLUETOOTH™ IMPLEMENTATION?

LOCK-ON TO BLUETOOTH SOLUTIONS FROM ST

Key to your success in Bluetooth Wireless Technology is the availability of competitive, high performance solutions. ST addresses this need with both single chip and 2-chip solutions.

The single chip STLC2400, designed on an advanced 0.18µ CMOS process with superior RF characteristics, combines a radio front-end with complex digital circuitry.

The 2 chip solution consists of :

- STLC2150, a state of the art CMOS class 2 radio, extendable to class 1, using the ST PA STB7710
- STLC2410, a full function baseband, offering high flexibility through software programmability and its various interfaces.

The STLC2400 and STLC2410 are based on Ericsson technology, guaranteeing proven interoperability and world class performance. ST's relationship with EBT also provide customers with efficient qualification services for their end product. This together with our application engineering support is the key to fast time to market.

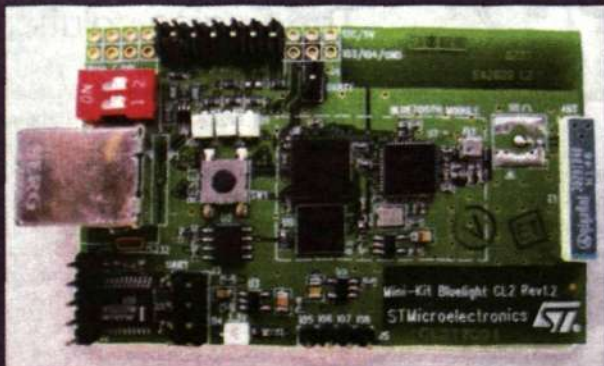

STLC2400 Single Chip

- Fully integrated Bluetooth system
- Embedded RF, Baseband, ROM, RAM, MCU and peripherals
- RFCMOS8 process adapted for single chip
- Small size and high volume product

STLC2410 Baseband

- Full function base-band
- Integrated ARM7TDMI
- 64 Kbytes internal SRAM
- 4 Kbytes internal boot ROM
- External Flash on EMI bus

STLC2150 Radio

- Fully integrated single chip
- Transceiver with no external RF components
- on-chip VCO with self calibration
- Power Class 2 and 3

STLC2450 Evaluation Board

- USB, RS232, SPI, I²C
- PCM, JTAG, GPIO
- Including software stack up to HCI
- HOST side software

For more information on the full range of ST wireless products,
contact your ST sales representative, or go to www.st.com



Helping lead the way

"BLUETOOTH" is a trademark owned by Telefonaktiebolaget L. M. Ericsson, Sweden.

Solving 2G and 3G handover problems

"The most difficult operation in a traditional mobile system is handover from one cell to another. Here it's a question not only of going from one cell, but also one system, to another," says Erik Schön, who is responsible for signaling issues in system design for the radio interface.

"A key issue for the introduction of 3G is to allow the user to switch between the 3G WCDMA and 2G GSM systems," says Mikael Halén, marketing manager for WCDMA. "The WCDMA standard is designed to support interoperation with GSM, and if you can execute handovers between the two systems, operators can build out their 3G networks in a flexible manner while providing full coverage from day one."

Ericsson recently became the world's first supplier to demonstrate handover between WCDMA and GSM in practice. This accomplishment was the result of ten years' research and development work in which Ericsson has been the driving force in standardizations efforts that included developing a patented solution within the 3GPP standards body for WCDMA.

The solution, which is called compressed mode, allows WCDMA phones to measure signals in GSM cells without having an extra receiver. In GSM, which is based on time slots, the phone uses empty slots. Because WCDMA lacks time slots, it is therefore necessary to create a gap in the continuous stream of data frames.

This is accomplished by changing spread spectrum code, while doubling the data rate (and transmission power) to produce frames that are five milliseconds long instead of ten, for example, and which are preceded and followed by more data (see diagram). Compressed mode is used when there is a need to change to GSM and is repeated at a certain interval.

Handover between frequencies

In a WCDMA network, all calls are carried on the same frequency and distinguished by codes. To increase network capacity, the operator can use two frequencies. Handovers are then either soft using the same frequency or hard when two frequencies are involved. Hard handovers are used in going from WCDMA to GSM.

A handover from WCDMA to GSM consists of a number of steps (see illustration). The phone (UE, User Equipment) in a WCDMA cell detects that the connection is fading. Because the existing GSM network provides greater coverage, there is a GSM cell in the vicinity. The RNC (Radio Network Controller)

that controls the base station in the WCDMA network receives information from the UE that the connection is failing (1) and sends commands to the UE (2) to make it use compressed mode. The UE starts monitoring GSM cells, finds one that has sufficient signal strength and reports this finding to the RNC (3).

The RNC then notifies the BSS (Base Station System) in the GSM network, which allocates resources for a handover (4) and sends commands for a GSM handover for the UE via the MSC (Mobile Switching Center) and the RNC that are embedded in other signal traffic (5). The phone changes mode from WCDMA to GSM (6) and connects to the GSM cell (7). Finally, the handover is confirmed by additional signals between the nodes.

Driving the standard

"Ericsson has driven the standardization effort and in 1998 became the first supplier to provide a detailed WCDMA-to-GSM handover specification in which the signal sequences according to this procedure were defined," says Anders Lundqvist, who is responsible for system design for the radio interface.

"Our success is based on an extensive and fruitful cooperation throughout all of Ericsson that includes research, hardware and software development, terminals, system design, integration and verification for both GSM and WCDMA in which the system designers were involved in node design and testing.

Conversion required

"The challenge has been to handle the complex transfer between systems in a manner that is unnoticeable to users. Everything pertaining to a service in one system must be transferred to the other system. This takes time and leaves no margin for errors," note system designers Gertie Alsenmyr and Anders Milén.

Another important consideration is interoperability, meaning that equipment from different suppliers must work together.

"We have been working for about three years with the leading phone suppliers to ensure that there will be a wide range of phones available when operators launch their services," says Mikael Halén.

"This work is proceeding according to plan. On the systems side, we are working at full speed to integrate equipment from different suppliers. Europe's first commercial 3G network, which was taken into operation by Mobilkom in Austria in September, was also the first network in which equipment from different suppliers (Ericsson plus one other) was integrated from the start, thus proving that we have a stable and well-functioning 3G standard," concludes Mikael Halén.

LARS CEDERQUIST

lars.cederquist@lme.ericsson.se

HANDOVER

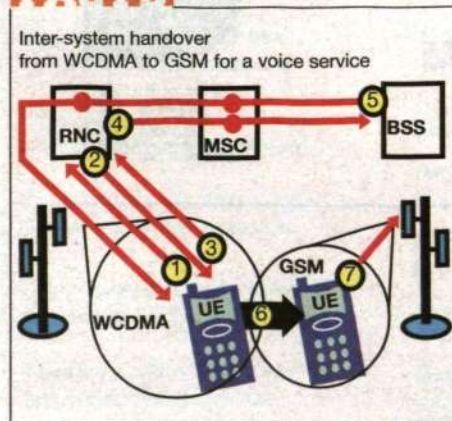

COMPRESSED MODE

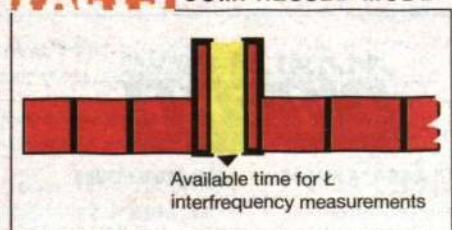

Closer cooperation in production testing

At the end of September, Test Development in Gävle arranged a tour for product designers in Mölndal. The goal was to show how test systems are developed within mobile systems with the objective of strengthening cooperation between design and production testing for WBTS.

The tour included a demonstration of the Wurlitzer platform which is used to test all digital and radio circuit boards for 3G base stations. This platform permits thorough testing of early prototypes, while providing great flexibility in production, since it can be configured for circuit boards of many different types, which currently number about 60.

Latest facility for antenna measurements

On November 21, Ericsson Microwave Systems in Mölndal, in western Sweden, will open Europe's most modern test facility for antennas and antenna systems. The test lab will handle a broad frequency spectrum and is dimensioned to measure most of Ericsson's antenna models for such products as base stations, microwave links and radar. External customers will also be able to use the facility, which will be accredited in cooperation with the Swedish Institute for Research and Testing in Borås.

More efficient design tools

When Ericsson and the US tools supplier Mentor Graphics held their eleventh exposition and symposium in early September, simulation and more rapid design verification were two key topics.

"The trend in electronics towards more transistors and functions per unit of chip surface gives us new opportunities, yet also poses new problems," says Tom Stadler, who is responsible for tools and methods for hardware at Ericsson. "Physical problems arise with respect to signal transmission and heat, and it becomes harder to verify that designs are correct. More efficient tools are needed, and we have to use the best tools available."

It is increasingly common that characteristics, rather than functions, are simulated, and verification now accounts for more than half of the design time. One solution is to use more powerful computers and more intelligent algorithms.

"Another approach is to get it right from the start. This requires better design support at the system level where there are now tools for modeling systems at an early stage and at a high level. Designing for reusability is a third method for increasing design efficiency," notes Tom Stadler.

Mentor Graphics together with Cadence is a principal supplier of hardware tools to Ericsson.

Book meeting participants and conference rooms in Outlook. Open the Calendar, select the time for the meeting and click Attendee Availability. At the bottom of this tab, you will see the Invite others button. Click it and the Global Address list will open. If you enter Conf SE HF, you will get a list of all conference rooms in Sweden at HF, including the building and room numbers.

The figure in parentheses indicates how many people the room accommodates. Enter Conf CH BE, and you will get a list of all conference rooms in Bern, Switzerland.

To find out what equipment is available, click Properties and then Phone/Notes.

mail.ericsson.se/support/userguides/confrooms/guide2000/quick.shtml

IMPROVE DATA RELIABILITY WITH PROFIBUS-COMPLIANT, FAIL-SAFE RS-485 TRANSCEIVERS

2.1V Output, 2ns Skew, 20ns Propagation Delay
Exceed Profibus Specifications

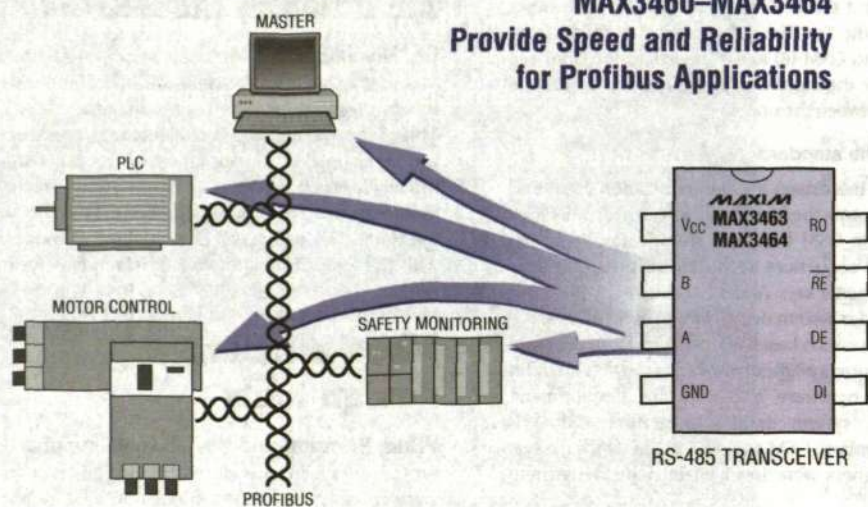

Advantages Over the Competition:

- ◆ Hot-Swap Circuitry Eliminates Data Glitches During Hot Insertion
- ◆ True Fail-Safe Receiver Input Guarantees an Output High if the Receiver is Open, Shorted, or All Drivers are High Impedance
- ◆ 1/4 Unit Load Allows 128 Transceivers on the Bus
- ◆ Uses 80% Less Power

Other Benefits:

- ◆ Profibus Compliant
- ◆ 1 μ A Shutdown Mode Saves System Power

Part	Power Supply (V)	Half/Full Duplex	Data Rate (Mbps)	Shutdown	Hot-Swap	True Fail-Safe	Pin-Package	Price [†] (\$)
MAX3460	+5	Full	20	Yes	Yes	Yes	14-SO/14-DIP	2.92
MAX3461	+5	Full	20	Yes	No	Yes	14-SO/14-DIP	2.92
MAX3462	+5	Full	20	No	No	Yes	8-SO/8-DIP	2.92
MAX3463	+5	Half	20	Yes	Yes	Yes	8-SO/8-DIP	2.92
MAX3464	+5	Half	20	Yes	No	Yes	8-SO/8-DIP	2.92

†1000-up recommended resale, FOB USA. Price provided is for design guidance and is FOB USA. International prices will differ due to local duties, taxes, and exchange rates. Not all packages are offered in 1k increments, and some may require minimum order quantities.



FREE Interface Design Guide—Sent Within 24 Hours!
Includes: Reply Cards for Free Samples and Data Sheets

2002 EDITION!
FREE FULL-LINE DATA CATALOG
ON CD-ROM

Call For a Design Guide or Free Sample
U.K. (44) 118 9303388
Toll-Free in the U.S. 1-800-998-8800



MAXIM
www.maxim-ic.com



MAXIM/DALLAS
DIRECT!
DISTRIBUTION

1-888-MAXIM-IC (44) 118 9303388

A real champion

Mai-Quyen Bui has two careers. She is a technician working at Ericsson in the US, but she is also a long-time international badminton champion. Most recently, she played the Ladies Friendship Open in Japan, and won the bronze.

"I just did the best I could, and there were many strong teams there," says Mai-Quyen Bui modestly.

Mai-Quyen Bui refers to badminton as her "first career." For ten years, she was the Vietnamese national champion and also coached the national team. Not long after moving to the US, she won the first of several American national gold medals.

Mai-Quyen Bui's other career is as an engineering technician at Ericsson's production lab in Reston, Virginia, where she tests and integrates new TEMS products. A little support

from her co-workers helped her combine the two: they arranged several well-attended ice-cream socials to help her pay the airfare to Japan.

"I can barely believe it, they've been great. They put my face all over the building," Mai-Quyen Bui says and laughs.

Before returning to work, she is taking the opportunity to go to Vietnam to visit her brother, who first introduced her to badminton.

"But he won't play against me, unless I give him extra points," Mai-Quyen Bui exclaims. "I will try to convince him to play, but I think it might mean an even harder game than in the championship. Especially if I beat him."



Mai-Quyen Bui is a skilled technician and badminton player.



ELIN AHLDÉN

elin.ahlden@lme.ericsson.se

from the archives

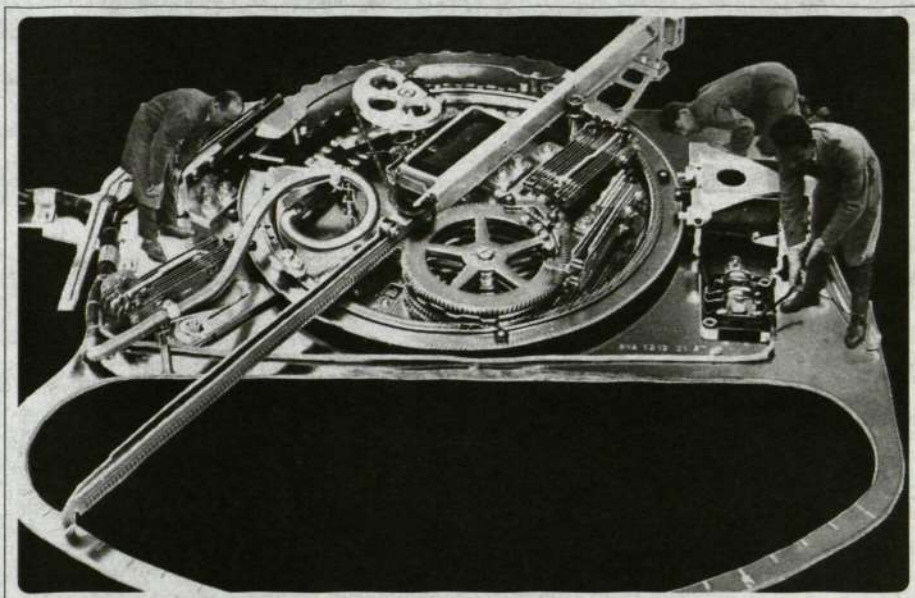

The world's largest model of Ericsson's 500-point selector was made in 1957, and primarily used when training new employees. The selector is a true Ericsson classic. It was first installed in Sweden in 1923 and by 1974 4.8 million commercial stations were in use worldwide.

MMS mystery solved

Getting ready to launch MMS, China Mobile asked Ericsson to help arrange a joint MMS application contest. Software developers from all over China submitted 60 applications, and the top ten entries now make up the first batch of applications that China Mobile can offer end-users. In addition to ten top-notch applications, China Mobile is pleased to have raised public awareness of MMS. The winning application lets the end-user receive clues in the form of pictures, sound and text in a mysterious MMS message. Then it is time to solve the mystery.



Support one click away

A new extranet for IT support for Ericsson employees in Australia and Western Europe has been launched. It is a new version of the former Harvest extranet, and has been developed in collaboration with EDS. Services offered range from support services, relocation services, warranty claims and outsourcing, as well as information regarding Ericsson's contracts with EDS. The extranet also includes contact information and feedback opportunities.

eds-it.ericsson.se

new assignments

Jin Soo (Thomas) Hwang is the new head of Market Unit South Korea, country manager for Korea and president of Ericsson Korea Ltd. He was previously responsible for Business Development at Ericsson in Korea.

Per Freden has been appointed key account manager Telefónica Móviles Mexico.



Per Freden

Maurizio De Dominicis, currently key account manager for Spanish mobile operator AMENA, has been appointed key account manager for the OTE Group & INTRACOM in market unit South East Europe.

Mark Ritter has been appointed vice president for Services in Market Unit Australia and New Zealand. He has previously been managing the Wireline Account for Telstra.

contact

CORPORATE EDITOR, PUBLISHER

Lars-Göran Hedin, +46 8-719 98 68, lars-goran.hedin@lme.ericsson.se

ASSISTANT EDITOR

Ingrid Båvsjö, +46 8-719 08 95
ingrid.bavsjo@lme.ericsson.se

NEWS EDITOR

Henrik Nygård, +46 8-719 18 01
henrik.nygard@lme.ericsson.se

PRODUCTION MANAGER 5MINUTES

Ulrika Nybäck, +46 8-719 34 91
ulrika.nyback@lme.ericsson.se

EDITOR, TECHNOLOGY

Lars Cederquist, +46 8-719 32 05
lars.cederquist@lme.ericsson.se

EDITOR, WORLD WATCH

Sara Morge, +46 8-719 23 57
sara.morge@lme.ericsson.se

EDITORIAL STAFF

Dodi Axelsson, +46 8-719 24 18
dodi.axelsson@lme.ericsson.se

Lars-Magnus Kihlström, +46 8-719 41 09
lars-magnus.kihlstrom@lme.ericsson.se

Tonya Lilburn, +46 8-719 32 02
tonya.lilburn@lme.ericsson.se

Jesper Mott, +46 8-719 70 32
jesper.mott@lme.ericsson.se

Jenz Nilsson, +46 8-719 00 36
jenz.nilsson@lme.ericsson.se

Gunilla Tamm, +46 8-757 20 38
gunilla.tamm@lme.ericsson.se

EDITOR, AROUND ERICSSON

Elin Ahlden, +46 8-719 69 43
elin.ahlden@lme.ericsson.se

LAYOUT AND WEB DESIGN

Paues Media, +46 8-665 73 80

EXTERNAL ADVERTISING

Display AB, +46 90-71 15 00

DISTRIBUTION

PressData
Box 3263
SE-103 65 Stockholm
phone: +46 8-799 63 28
fax: +46 8-28 59 74
contact@pressdata.se

PRINTED AT:

Nerikes Allehanda Tryck Örebro, 2002

ADDRESS

Telefonaktiebolaget LM Ericsson,
HF/LME/DI
SE-126 25 Stockholm
fax +46 8-681 27 10
kontakten@lme.ericsson.se

CONTACT ON THE WEB

http://www.ericsson.se/
SE/kon_con/contact





column

LARS-GÖRAN HEDIN
corporate editor

Finally, somebody who 'gets it'

About two years ago, I upgraded my mobile phone subscription to include GPRS services. I was rewarded with Ericsson's handsome, gold-colored GPRS telephone R520. Since then, it's been exchanged for the even cooler T68. But, I must admit, I haven't used so many of the GPRS services. Getting started with GPRS wasn't so simple. It took several tries and a lot of help from friends near and far before the telephone and SIM card were suitably configured. And still today, many months later, I've not managed to get data communication via RACOM to transfer at a better rate than the 9,600 kbs that the GSM network offers.

I don't imagine myself to be a 'superuser' of mobile data, but I'm not dumber than average. I seem to share these shortcomings with just about every other person I know who has a GPRS telephone. No wonder the services haven't become the commercial success that so many hoped for at the introduction.

Despite the fact that the technology is in the networks and in mobile handsets, it doesn't seem like operators have figured out how to offer a service that anyone can use. And that doesn't require hours of frustration on Internet sites, telephone manuals and other instructions.

I've now read the article in this edition of *Contact* about Vodafone's new service Vodafone Live. It's about MMS services that are so easy to use that anyone can manage to use them. One of the great ideas that Vodafone is using is to sell the service with telephones that are already configured and ready to use! Imagine, it's just like buying a new car – just turn the key in the ignition and drive off the lot. Instead of – to stretch the point – starting by balancing the tires, screwing together the motor, installing the instrument panel and then sewing the interior... Who on earth wants to buy a car that way?

We who are waiting for a new shot of life in the telecoms market are just hoping that more operators follow Vodafone's good example! And that Sony Ericsson is among the suppliers that deliver terminals to the next operator who thinks first, and sells later.



Sending and receiving images by mobile phone are among the features offered by the Vodafone Live portal. In its launch, Vodafone emphasizes that the portal services are easy to use and there is no mention of the technology that enables the various services.

Many services – invisible technology

In the end of October, Vodafone presented its answer to Japan's i-Mode. The launch took place through the Vodafone Live portal in Germany, the UK, the Netherlands, Italy and Spain.

With Vodafone Live, the user can send and receive color images, download games, ring signals and view the latest sports results, among other features. In its launch, Vodafone underlines that the services are easy to use and nothing is said about the underlying technology.

At the same time, MMS and Java phones from Sharp, Panasonic, Nokia, and other manufacturers, are being rolled out under Vodafone's own brand.

Vodafone Live is the Vodafone Group's largest single global venture to date. A similar launch is planned for the beginning of next year in Vodafone's other European markets, as well as in the Asia-Pacific region.

"Vodafone Live is also very important for Ericsson because now the services and experience for the consumer are being highlighted rather than the technology. This could be a turning point to provide a real boost to traffic in mobile networks. At the same time, it is the first major launch of MMS," says Thomas Granström at Ericsson's glob-

al customer unit (GCU) for Vodafone, where he is head of Internet Solutions & Applications.

In addition to the infrastructure for Vodafone's GPRS system, Ericsson also delivered the service platforms for MMS and Multimedia Library, as well as integration and consulting services. At the same time as Vodafone Live, the operator also made a preliminary launch of Vodafone Mobile Office, comprising various services for companies. The enterprise sector is a significant market for the Vodafone Group and in the future the operator will focus increasingly on innovative data and voice services in this market segment.

"This is also an area in which Ericsson is well-positioned to become a partner for Vodafone by offering more solutions," adds Thomas Granström.

GUNILLA TAMM

gunilla.tamm@ime.ericsson.se

www.vodafone.com

The ericsson to share

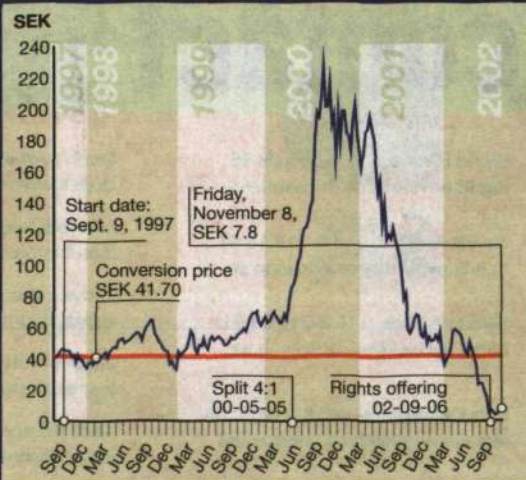

For additional information, access the website:
<http://inside.ericsson.se/convertibles>